

**SEALMASTER®**



# UNITIZED SPHERICAL ROLLER BEARINGS

**REGAL®**

## ***Another bearing breakthrough from the name you trust***

*For more than 70 years, the Sealmaster® name has meant the very best in bearing quality, reliability and performance. Over those years, we have brought an array of cutting-edge technical improvements and platform advancements to applications around the world. Since 1976, Sealmaster Roller Pillow Block (RPB) tapered roller bearings have set the standard for performance in some of the toughest job sites.*

---

Regal is continuing our tradition of innovation, with the Sealmaster USRB™ unitized spherical roller bearing. This new series builds on the rich heritage of past Sealmaster bearings and brings you design enhancements of an entirely new level.

The Sealmaster USRB unitized spherical roller bearing is available in two distinct locking systems: collar mount with bore sizes from 1 1/8" to 7"; and adapter mount with bore sizes from 1 1/8" to 8". Its race-mounted seals accommodate +/-2° misalignment. Plus, for easy installation and maintenance, the new pillow blocks from 5 7/16" to 8" are shaft ready with replaceable cartridge inserts that mount more quickly than competitive versions. Just as important, the new Regal® Sealmaster performance mounted roller bearing brings you the time-tested reliability of the Sealmaster brand, a unique advantage that helps maximize uptime and minimize overall operating costs.

Our engineers have developed new geometries that let us create an innovative double-row spherical roller bearing for load capacity, misalignment and speed capabilities. The Sealmaster performance mounted roller bearing is an advanced spherical roller bearing design that combines traditional Sealmaster bearing features and built-in benefits with even more performance and value. Among the key design features of the Sealmaster performance mounted roller bearing are two locking systems.

Sealmaster USRB unitized spherical roller bearing collar mount bearings are anchored to the shaft with concentric locking collars and setscrews at 120°, providing a balanced three-point contact and extra holding power.

Sealmaster USRB unitized spherical roller bearing adapter mount bearings grip the shaft with an advanced adapter-lock system for fast installation and removal. Our advanced integral locking system incorporates axial cap screws that let you mount and dismount the bearing from one side. The result: this highly engineered locking system requires less force and installs more quickly than competitive bearings. Sealmaster USRB unitized spherical roller bearings are also shaft ready and require only a hex key and torque wrench to install.

The new Sealmaster mounted spherical roller bearing blends traditional Sealmaster bearing features with innovative technology, for exceptional performance. This combination dramatically cuts the potential for downtime and provides the kind of interchangeability, lower operating costs and reliability you need to keep your equipment – and your business – running 24/7.

# Table of Contents

USRB™ Bearing Features and Benefits	_____	3-4
Pillow Block USRB5000 & 5000A	_____	4-5
Pillow Block USRBF5000 & 5000A	_____	7-8
Pillow Block USRB5500 & 5500A	_____	7-8
Flange Block USFB5000 & 5000A	_____	9-10
Flange Cartridge USFC5000 & 5000A	_____	11-12
Flange Bracket USBF5000 & 5000A	_____	11-12
Take-Up USTU5000 & 5000A	_____	13-14
Pillow Block USRBE5000 & 5000A	_____	15-16
Flange Block USFBE5000 & 5000A	_____	17-18
Flange Cartridge USFCE5000 & 5000A	_____	19-20
Flange Block USF3B5000	_____	21
Spherical Inserts USI5000 & 5000A	_____	22
Engineering Section	_____	23-34
General Engineering	_____	23-28
Lubrication	_____	29
Vibration Analysis	_____	30
Installation	_____	31-34

## Sealmaster® USRB™ Bearing Nomenclature

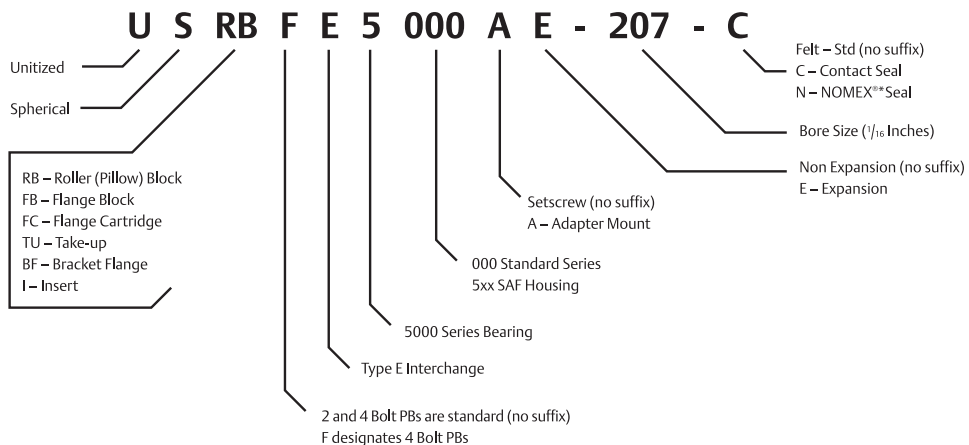

\*Nomex is believed to be the trademark and/or trade name of E. I. Du Pont De Nemours and Company and is not owned or controlled by Regal Beloit Corporation.

### **Felt Seal**

The Sealmaster® felt-lined rotating flinger seal, mounted between races, allows up to  $\pm 2^\circ$  of misalignment. The outer member rotates with the inner race to help direct contamination away from the seal. Due to the unique spherical geometric design of the seal contact areas, sealing effectiveness is maintained throughout the entire specified range of misalignment. The felt design provides a tight labyrinth seal, which acts as a filter to help exclude foreign material and has low friction. The seal stampings are black oxide coated for corrosion resistance.

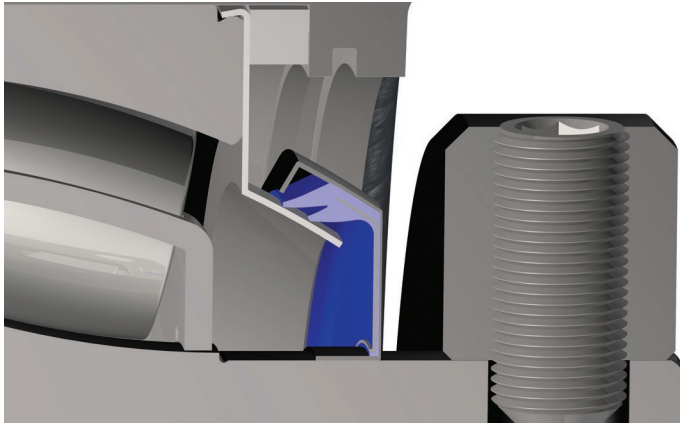

### **Contact Seal**

Contact seal (patent pending) – The Sealmaster® double-lip contact seal, mounted between races, also allows up to  $\pm 2^\circ$  of misalignment. The outer member rotates with the inner race, to help direct contamination away from the seal. Due to the unique spherical geometric design of the seal contact areas, sealing effectiveness is maintained throughout the entire specified range of misalignment. This seal operates with low drag, making it a smart choice for dry, dusty or wet conditions. The rotating double-lip hinge seal design delivers exceptional limiting speed.

### **Misalignment**

The arrangement of rolling elements and races in Sealmaster® mounted spherical roller bearings compensates for  $\pm 2^\circ$  of misalignment – up to twice an SAF – while maintaining catalog load ratings and sealing effectiveness. The Sealmaster mounted spherical roller bearing has a replaceable cartridge insert that consists of a double-row spherical roller bearing with patented race-mounted seals. These integrally sealed, one-piece cartridge inserts can also be used for mounting in cylindrical-bore housings for an even wider range of applications, including extruders, mill equipment and coating lines, where space is at a premium.

### **One-Piece Housing**

Durable one-piece cast-iron housings for shaft sizes from  $1 \frac{1}{8}''$ – $5''$ . Ductile iron housings with type E mounting dimensions from  $1 \frac{15}{16}''$ – $4''$ .

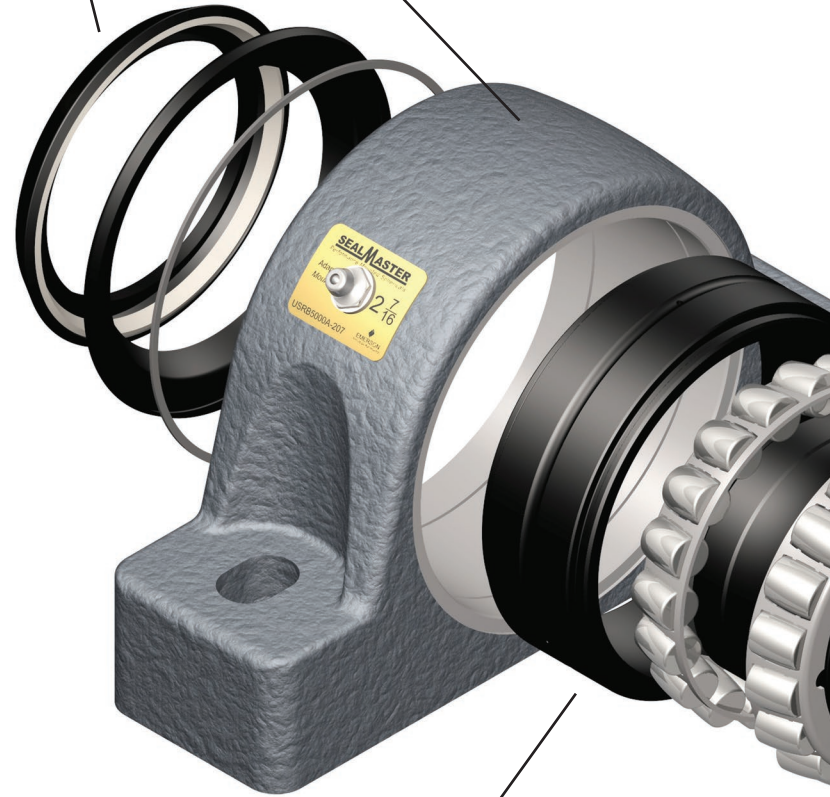

### **Wide Outer Race**

The wide outer race, coupled with innovative rolling-element geometries, provides higher load capacity and more insert stability in the housing. More important, the wide outer race provides for better sealing and creates a large internal grease chamber, for more grease capacity. The outer races are black oxide coated for corrosion protection. All Sealmaster® USRB™ unitized spherical roller bearings contain high-capacity double-row spherical roller bearings designed to handle a combination of loads. New geometries developed by Sealmaster bearing engineers result in an innovative double-row spherical roller bearing with load capacity, misalignment and speed capability.

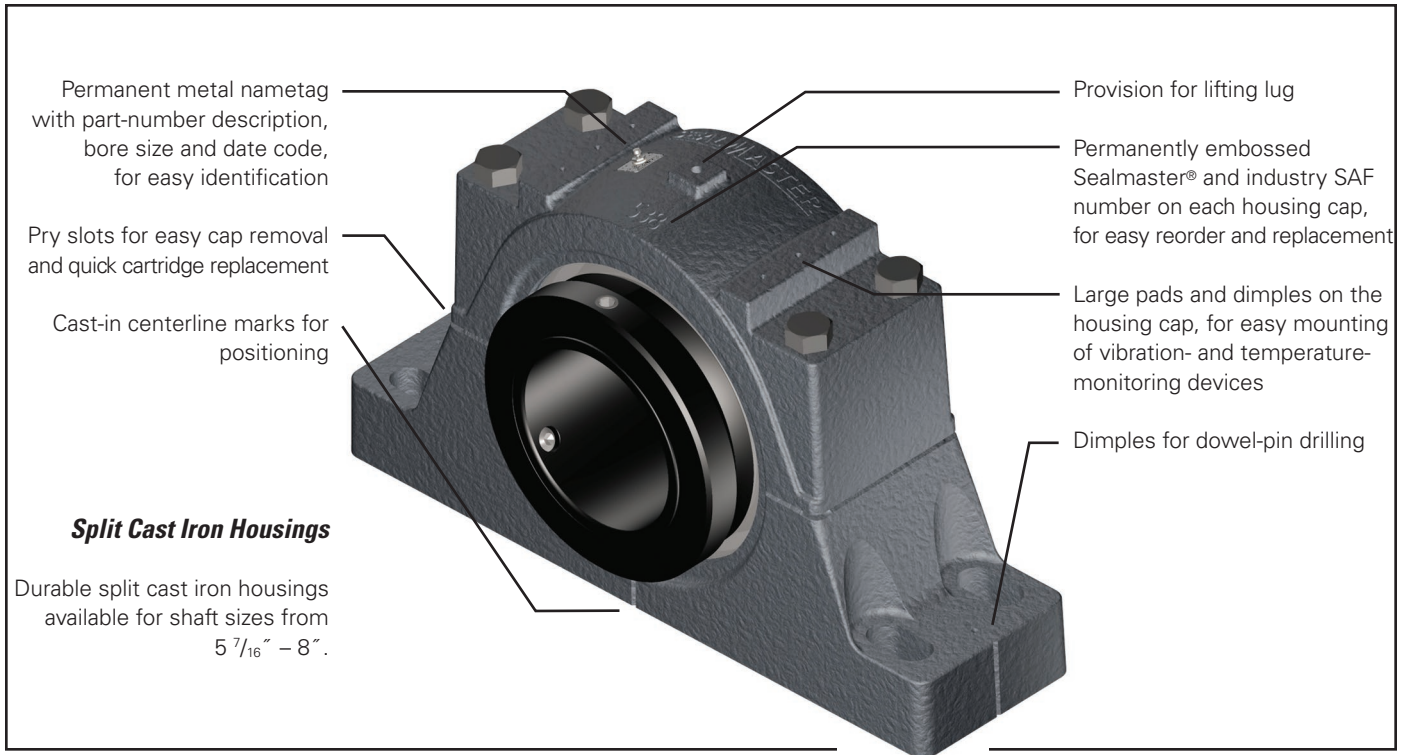

Permanent metal nametag with part-number description, bore size and date code, for easy identification

Provision for lifting lug

Pry slots for easy cap removal and quick cartridge replacement

Permanently embossed Sealmaster® and industry SAF number on each housing cap, for easy reorder and replacement

Cast-in centerline marks for positioning

Large pads and dimples on the housing cap, for easy mounting of vibration- and temperature-monitoring devices

Dimples for dowel-pin drilling

### **Split Cast Iron Housings**

Durable split cast iron housings available for shaft sizes from 5 7/16" - 8".

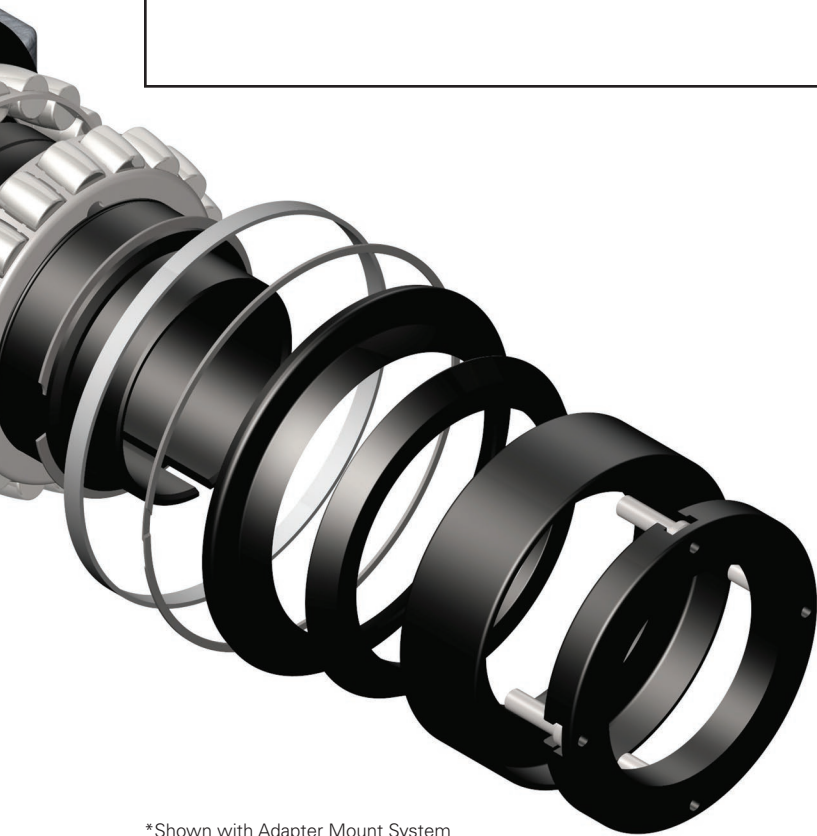

\*Shown with Adapter Mount System

### **Collar Mount**

Sealmaster® performance mounted roller bearing pillow blocks are anchored to the shaft with two concentric locking collars and setscrews at 120°, providing a balanced three-point contact and extra holding power.

### **Adapter Mount\***

The Sealmaster® performance mounted roller bearings grip the shaft with an advanced adapter mount system (patent pending), for fast installation and removal. Our advanced integral locking system incorporates axial cap screws that let you mount and dismount the bearing from one side. The result: this highly engineered locking system requires less force and installs up to six times more quickly than competitive bearings. Sealmaster mounted spherical roller bearings are also shaft ready and require only a hex key and torque wrench to install; no special tools or feeler gauges are required.

# Pillow Block

## USRB5000

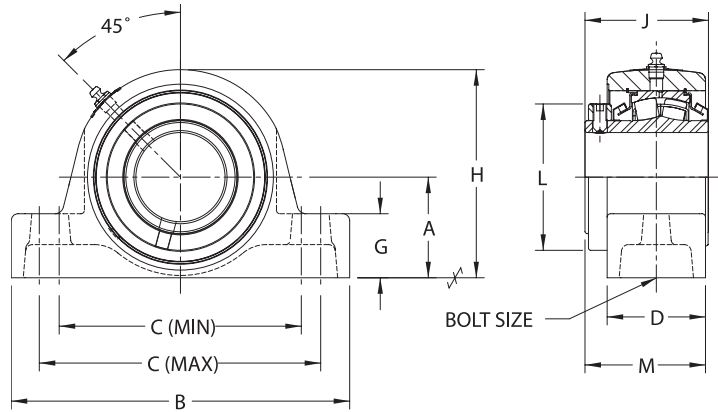
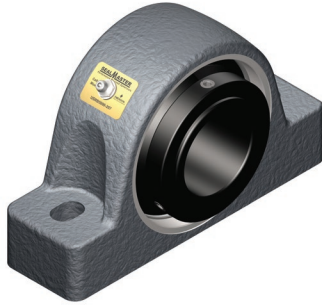

### Two Bolt Base, Collar Mount

Nomenclature	Shaft Diameter (INCHES)	A	B	C		D	G	H	J	L	M*	Bolt Size
				MIN.	MAX.							
USRB5000-102	1 1/8											
USRB5000-103	1 3/16	1 3/4	6 5/16	4 1/2	5	2 3/16	1 1/16	3 3/4	2 3/4	2 49/64	2 3/4	3/8
USRB5000-104	1 1/4											
USRB5000-106	1 3/8											
USRB5000-107	1 7/16	1 7/8	6 7/8	4 11/16	5 5/16	2 3/16	1 3/16	3 7/8	2 3/4	2 49/64	2 3/4	1/2
USRB5000-108	1 1/2											
USRB5000-111	1 11/16	2 1/8	7 3/8	5 3/16	5 13/16	2 3/16	1 5/16	4 1/4	2 7/8	2 3/4	2 51/64	1/2
USRB5000-112	1 3/4											
USRB5000-115	1 15/16	2 1/4	8 3/8	5 5/16	6 9/16	2 3/16	1 3/8	4 9/16	2 7/8	3	2 25/32	5/8
USRB5000-200	2											
USRB5000-203	2 3/16	2 1/2	8 7/8	6 9/16	7 1/16	2 7/16	1 5/8	5	3 1/8	3 1/4	3 5/64	5/8
USRB5000-207	2 7/16	2 3/4	9 1/4	6 13/16	7 7/16	2 11/16	1 3/4	5 11/16	3 3/8	4	3 9/32	5/8
USRB5000-208	2 1/2											
USRB5000-211	2 11/16											
USRB5000-212	2 3/4	3 1/4	10 7/16	7 13/16	8 7/16	2 13/16	2 1/4	6 7/16	3 7/8	4 17/32	3 3/4	3/4
USRB5000-215	2 15/16											
USRB5000-300	3											
USRB5000-303	3 3/16	3 3/4	13	9 1/4	10 3/4	3 3/16	2 1/4	7 1/2	4 15/32	5 5/16	4 15/64	7/8
USRB5000-307	3 7/16											
USRB5000-308	3 1/2											
USRB5000-311	3 11/16	4 1/8	14 1/4	10	11 3/4	3 9/16	2 1/2	8 7/16	4 15/16	6	4 23/32	1
USRB5000-315	3 15/16											
USRB5000-400	4											

\* For expansion bearings, this dimension can increase by the corresponding value listed in Table 7 on page 27.

# Pillow Block

## USRB5000A

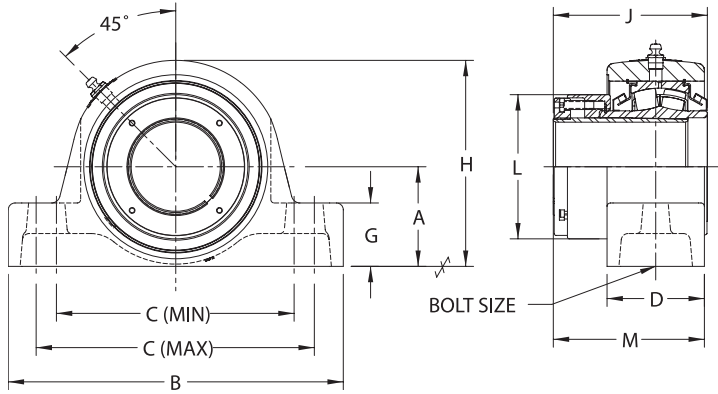

Two Bolt Base, Adapter Mount												
Nomenclature	Shaft Diameter (INCHES)	A	B	C		D	G	H	J	L	M*	Bolt Size
				MIN.	MAX.							
USRB5000A-102	1 1/8											
USRB5000A-103	1 3/16	1 3/4	6 5/16	4 1/2	5	2 3/16	1 1/16	3 3/4	3 11/32	2 47/64	3 11/32	3/8
USRB5000A-104	1 1/4											
USRB5000A-106	1 3/8											
USRB5000A-107	1 7/16	1 7/8	6 7/8	4 11/16	5 5/16	2 3/16	1 3/16	3 7/8	3 11/32	2 47/64	3 11/32	1/2
USRB5000A-108	1 1/2											
USRB5000A-111	1 11/16	2 1/8	7 3/8	5 3/16	5 13/16	2 3/16	1 5/16	4 1/4	3 29/64	2 63/64	3 3/8	1/2
USRB5000A-112	1 3/4											
USRB5000A-115	1 15/16	2 1/4	8 3/8	5 5/16	6 9/16	2 3/16	1 3/8	4 9/16	3 1/2	3 3/16	3 13/32	5/8
USRB5000A-200	2											
USRB5000A-203	2 3/16	2 1/2	8 7/8	6 9/16	7 1/16	2 7/16	1 5/8	5	3 57/64	3 29/64	3 27/32	5/8
USRB5000A-207	2 7/16	2 3/4	9 1/4	6 13/16	7 7/16	2 11/16	1 3/4	5 11/16	4 5/16	3 63/64	4 7/32	5/8
USRB5000A-208	2 1/2											
USRB5000A-211	2 11/16											
USRB5000A-212	2 3/4	3 1/4	10 7/16	7 13/16	8 7/16	2 13/16	2 1/4	6 7/16	4 31/64	4 25/64	4 3/8	3/4
USRB5000A-215	2 15/16											
USRB5000A-300	3											
USRB5000A-303	3 3/16											
USRB5000A-307	3 7/16	3 3/4	13	9 1/4	10 3/4	3 3/16	2 1/4	7 1/2	5 35/64	5 15/32	5 21/64	7/8
USRB5000A-308	3 1/2											
USRB5000A-311	3 11/16											
USRB5000A-315	3 15/16	4 1/8	14 1/4	10	11 3/4	3 9/16	2 1/2	8 7/16	5 15/16	5 13/16	5 23/32	1
USRB5000A-400	4											

\* For expansion bearings, this dimension can increase by the corresponding value listed in Table 7 on page 27.

# Pillow Block

## USRBF5000

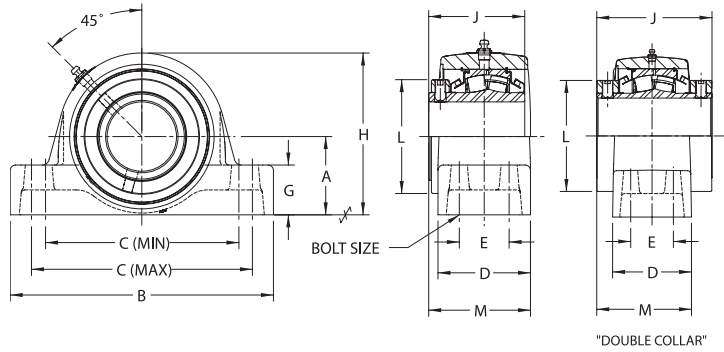
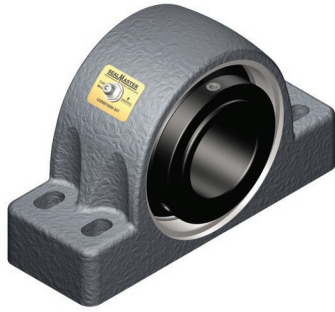

### Four Bolt Base, Collar Mount

Nomenclature	Shaft Diameter (INCHES)	A	B	C		D	E	G	H	J	L	M*	Bolt Size
				MIN.	MAX.								
USRBF5000-207	2 7/16	2 3/4	9 1/4	6 7/8	7 5/8	3 1/4	1 3/4	1 3/4	5 11/16	3 3/8	4	3 43/64	1/2
USRBF5000-208	2 1/2												
USRBF5000-211	2 11/16												
USRBF5000-212	2 3/4	3 1/4	10 7/16	7 7/8	8 3/8	3 3/4	1 7/8	2 1/4	6 7/16	3 7/8	4 17/32	4 19/64	5/8
USRBF5000-215	2 15/16												
USRBF5000-300	3												
USRBF5000-303	3 3/16												
USRBF5000-307	3 7/16	3 3/4	13	9 1/4	10 3/4	3 7/8	2	2 1/4	7 1/2	4 15/32	5 5/16	4 19/32	3/4
USRBF5000-308	3 1/2												
USRBF5000-311	3 11/16												
USRBF5000-315	3 15/16	4 1/4	15 1/4	11	13	4 1/2	2 1/4	2 5/8	8 9/16	4 15/16	6	5 13/64	3/4
USRBF5000-400	4												
USRB5000-407	4 7/16	4 3/4	16 3/64	13	14	4 5/8	2 1/2	2 3/4	9 3/8	6 3/4	6 1/2	5 39/64	3/4
USRB5000-408	4 1/2												
USRB5000-415	4 15/16	4 15/16	18 1/2	15	16	5 1/8	2 3/4	3	10 7/8	7 27/64	7	6 3/32	7/8

# Pillow Block

## USRB5500

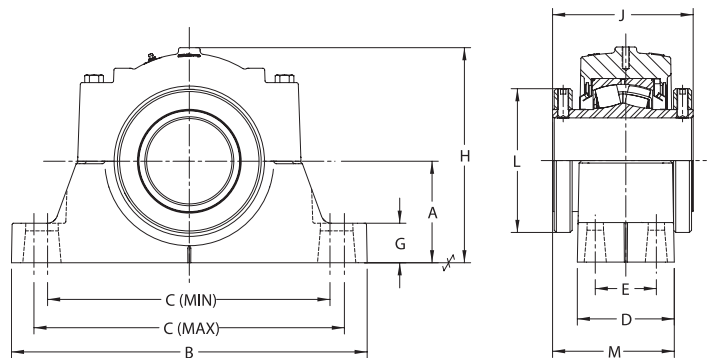
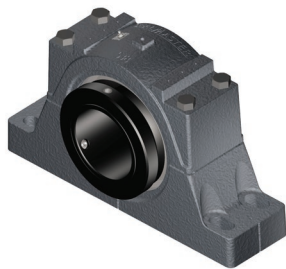

### Four Bolt Base, Collar Mount

Nomenclature	Shaft Diameter (INCHES)	A	B	C		D	E	G	H	J	L	M*	Bolt Size
				MIN.	MAX.								
USRB5532-507	5 7/16	6 11/16	22	17 3/8	19 1/4	6 1/4	3 3/4	2 5/8	13 17/32	9 1/32	8 1/2	7 27/32	1
USRB5534-515	5 15/16	7 1/16	24 3/4	19 3/8	21 5/8	6 3/4	4 1/4	2 3/4	14 31/32	9 25/32	10	8 15/32	1
USRB5536-607	6 7/16												
USRB5536-608	6 1/2	7 1/2	26 3/4	20 7/8	23 5/8	7 1/8	4 5/8	3	15 61/64	10 1/2	11	9 1/64	1
USRB5538-615	6 15/16												
USRB5538-700	7	7 7/8	28	21 5/8	24 3/8	7 1/2	4 1/2	3 1/8	16 9/16	10 1/2	11	9 13/64	1 1/4

\* For expansion bearings, this dimension can increase by the corresponding value listed in Table 7 on page 27.

## Pillow Block

### USRBF5000A

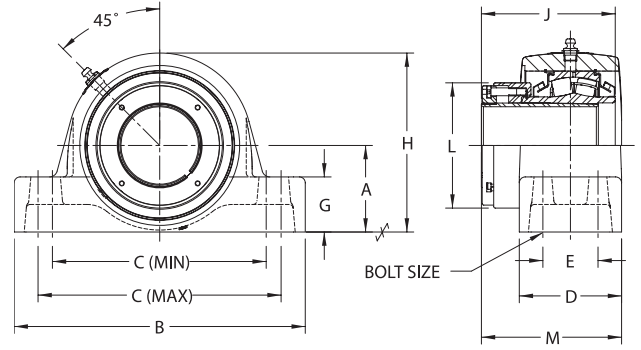
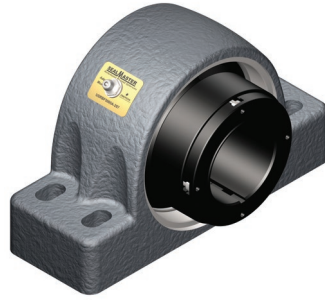

#### Four Bolt Base, Adapter Mount

Nomenclature	Shaft Diameter (INCHES)	A	B	C		D	E	G	H	J	L	M*	Bolt Size
				MIN.	MAX.								
USRBF5000A-207	2 7/16	2 3/4	9 1/4	6 7/8	7 5/8	3 1/4	1 3/4	1 3/4	5 11/16	4 5/16	3 63/64	4 39/64	1/2
USRBF5000A-208	2 1/2												
USRBF5000A-211	2 11/16												
USRBF5000A-212	2 3/4	3 1/4	10 7/16	7 7/8	8 3/8	3 3/4	1 7/8	2 1/4	6 7/16	4 31/64	4 25/64	4 29/32	5/8
USRBF5000A-215	2 15/16												
USRBF5000A-300	3												
USRBF5000A-303	3 3/16												
USRBF5000A-307	3 7/16	3 3/4	13	9 1/4	10 3/4	3 7/8	2	2 1/4	7 1/2	5 35/64	5 15/32	5 43/64	3/4
USRBF5000A-308	3 1/2												
USRBF5000A-311	3 11/16												
USRBF5000A-315	3 15/16	4 1/4	15 1/4	11	13	4 1/2	2 1/4	2 5/8	8 9/16	5 15/16	5 13/16	6 13/64	3/4
USRBF5000A-400	4												
USRBF5000A-407	4 7/16	4 3/4	16 3/64	13	14	4 5/8	2 1/2	2 3/4	9 3/8	6 27/64	6 11/32	6 31/64	3/4
USRBF5000A-408	4 1/2												
USRBF5000A-415	4 15/16	5 1/2	18 1/2	15	16	5 1/8	2 3/4	3	10 7/8	7 1/8	7 13/64	7 3/32	7/8
USRBF5000A-500	5												

## Pillow Block

### USRBF5500A

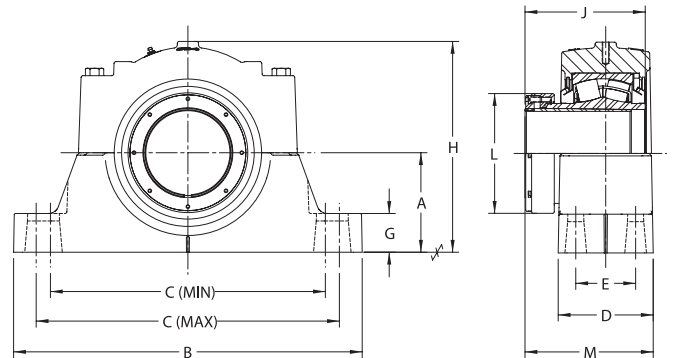

#### Four Bolt Base, Adapter Mount

Nomenclature	Shaft Diameter (INCHES)	A	B	C		D	E	G	H	J	L	M*	Bolt Size
				MIN.	MAX.								
USRBF5532A-507	5 7/16	6 11/16	22	17 3/8	19 1/4	6 1/4	3 3/4	2 5/8	13 17/32	7 35/64	7 47/64	8 17/64	1
USRBF5534A-515	5 15/16	7 1/16	24 3/4	19 3/8	21 5/8	6 3/4	4 1/4	2 3/4	14 31/32	8 17/32	8 1/2	9 7/64	1
USRBF5536A-607	6 7/16												
USRBF5536A-608	6 1/2	7 1/2	26 3/4	20 7/8	23 5/8	7 1/8	4 5/8	3	15 61/64	9 3/8	9 11/16	9 13/16	1
USRBF5538A-615	6 15/16												
USRBF5538A-700	7	7 7/8	28	21 5/8	24 3/8	7 1/2	4 1/2	3 1/8	16 9/16	9 3/8	9 11/16	10	1 1/4
USRBF5544A-708	7 1/2												
USRBF5544A-715	7 15/16	9 1/2	32 3/4	24 3/4	27 7/8	8 3/4	5 1/4	3 3/4	19 5/8	10 13/32	11 7/64	11 3/8	1 1/2
USRBF5544A-800	8												

\* For expansion bearings, this dimension can increase by the corresponding value listed in Table 7 on page 27.

# Flange Block

## USFB5000

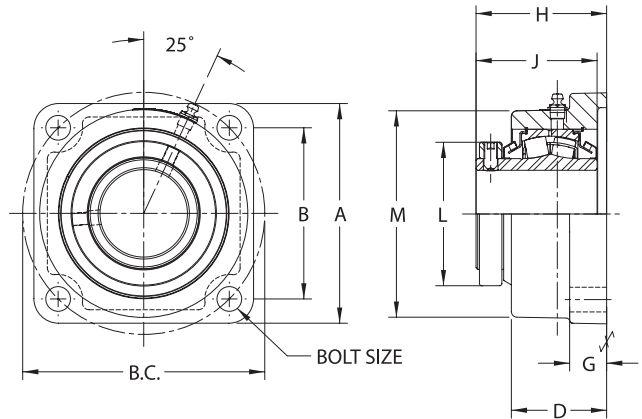

### Four Bolt Base, Collar Mount

Nomenclature	Shaft Diameter (INCHES)	A	B	B.C.	D	G	H*	J	L	M	Bolt Size
USFB5000-107	1 <sup>7</sup> / <sub>16</sub>	4 <sup>5</sup> / <sub>8</sub>	3 <sup>17</sup> / <sub>32</sub>	5	2 <sup>1</sup> / <sub>16</sub>	<sup>3</sup> / <sub>4</sub>	2 <sup>25</sup> / <sub>32</sub>	2 <sup>3</sup> / <sub>4</sub>	2 <sup>49</sup> / <sub>64</sub>	3 <sup>7</sup> / <sub>8</sub>	<sup>1</sup> / <sub>2</sub>
USFB5000-108	1 <sup>1</sup> / <sub>2</sub>	4 <sup>5</sup> / <sub>8</sub>	3 <sup>17</sup> / <sub>32</sub>	5	2 <sup>1</sup> / <sub>16</sub>	<sup>3</sup> / <sub>4</sub>	2 <sup>25</sup> / <sub>32</sub>	2 <sup>3</sup> / <sub>4</sub>	2 <sup>49</sup> / <sub>64</sub>	3 <sup>7</sup> / <sub>8</sub>	<sup>1</sup> / <sub>2</sub>
USFB5000-111	1 <sup>11</sup> / <sub>16</sub>	5	3 <sup>57</sup> / <sub>64</sub>	5 <sup>1</sup> / <sub>2</sub>	2 <sup>1</sup> / <sub>4</sub>	<sup>3</sup> / <sub>4</sub>	2 <sup>29</sup> / <sub>32</sub>	2 <sup>7</sup> / <sub>8</sub>	2 <sup>3</sup> / <sub>4</sub>	4 <sup>1</sup> / <sub>2</sub>	<sup>1</sup> / <sub>2</sub>
USFB5000-112	1 <sup>3</sup> / <sub>4</sub>	5	3 <sup>57</sup> / <sub>64</sub>	5 <sup>1</sup> / <sub>2</sub>	2 <sup>1</sup> / <sub>4</sub>	<sup>3</sup> / <sub>4</sub>	2 <sup>29</sup> / <sub>32</sub>	2 <sup>7</sup> / <sub>8</sub>	2 <sup>3</sup> / <sub>4</sub>	4 <sup>1</sup> / <sub>2</sub>	<sup>1</sup> / <sub>2</sub>
USFB5000-115	1 <sup>15</sup> / <sub>16</sub>	5 <sup>3</sup> / <sub>16</sub>	4 <sup>1</sup> / <sub>16</sub>	5 <sup>3</sup> / <sub>4</sub>	2 <sup>1</sup> / <sub>4</sub>	<sup>3</sup> / <sub>4</sub>	2 <sup>29</sup> / <sub>32</sub>	2 <sup>7</sup> / <sub>8</sub>	3	4 <sup>3</sup> / <sub>4</sub>	<sup>1</sup> / <sub>2</sub>
USFB5000-200	2	5 <sup>3</sup> / <sub>16</sub>	4 <sup>1</sup> / <sub>16</sub>	5 <sup>3</sup> / <sub>4</sub>	2 <sup>1</sup> / <sub>4</sub>	<sup>3</sup> / <sub>4</sub>	2 <sup>29</sup> / <sub>32</sub>	2 <sup>7</sup> / <sub>8</sub>	3	4 <sup>3</sup> / <sub>4</sub>	<sup>1</sup> / <sub>2</sub>
USFB5000-203	2 <sup>3</sup> / <sub>16</sub>	5 <sup>7</sup> / <sub>8</sub>	4 <sup>1</sup> / <sub>2</sub>	6 <sup>3</sup> / <sub>8</sub>	2 <sup>7</sup> / <sub>16</sub>	<sup>13</sup> / <sub>16</sub>	3 <sup>5</sup> / <sub>32</sub>	3 <sup>1</sup> / <sub>8</sub>	3 <sup>1</sup> / <sub>4</sub>	5 <sup>1</sup> / <sub>8</sub>	<sup>5</sup> / <sub>8</sub>
USFB5000-207	2 <sup>7</sup> / <sub>16</sub>	6 <sup>1</sup> / <sub>8</sub>	4 <sup>49</sup> / <sub>64</sub>	6 <sup>3</sup> / <sub>4</sub>	2 <sup>21</sup> / <sub>32</sub>	1 <sup>1</sup> / <sub>32</sub>	3 <sup>13</sup> / <sub>32</sub>	3 <sup>3</sup> / <sub>8</sub>	4	5 <sup>3</sup> / <sub>4</sub>	<sup>5</sup> / <sub>8</sub>
USFB5000-208	2 <sup>1</sup> / <sub>2</sub>	6 <sup>1</sup> / <sub>8</sub>	4 <sup>49</sup> / <sub>64</sub>	6 <sup>3</sup> / <sub>4</sub>	2 <sup>21</sup> / <sub>32</sub>	1 <sup>1</sup> / <sub>32</sub>	3 <sup>13</sup> / <sub>32</sub>	3 <sup>3</sup> / <sub>8</sub>	4	5 <sup>3</sup> / <sub>4</sub>	<sup>5</sup> / <sub>8</sub>
USFB5000-211	2 <sup>11</sup> / <sub>16</sub>										
USFB5000-212	2 <sup>3</sup> / <sub>4</sub>	7 <sup>3</sup> / <sub>16</sub>	5 <sup>9</sup> / <sub>16</sub>	7 <sup>7</sup> / <sub>8</sub>	2 <sup>7</sup> / <sub>8</sub>	<sup>15</sup> / <sub>16</sub>	3 <sup>57</sup> / <sub>64</sub>	3 <sup>7</sup> / <sub>8</sub>	4 <sup>17</sup> / <sub>32</sub>	6 <sup>5</sup> / <sub>8</sub>	<sup>3</sup> / <sub>4</sub>
USFB5000-215	2 <sup>15</sup> / <sub>16</sub>	7 <sup>3</sup> / <sub>16</sub>	5 <sup>9</sup> / <sub>16</sub>	7 <sup>7</sup> / <sub>8</sub>	2 <sup>7</sup> / <sub>8</sub>	<sup>15</sup> / <sub>16</sub>	3 <sup>57</sup> / <sub>64</sub>	3 <sup>7</sup> / <sub>8</sub>	4 <sup>17</sup> / <sub>32</sub>	6 <sup>5</sup> / <sub>8</sub>	<sup>3</sup> / <sub>4</sub>
USFB5000-300	3										
USFB5000-303	3 <sup>3</sup> / <sub>16</sub>	8 <sup>3</sup> / <sub>8</sub>	6 <sup>23</sup> / <sub>32</sub>	9 <sup>1</sup> / <sub>2</sub>	3 <sup>7</sup> / <sub>32</sub>	1 <sup>1</sup> / <sub>8</sub>	4 <sup>1</sup> / <sub>2</sub>	4 <sup>15</sup> / <sub>32</sub>	5 <sup>5</sup> / <sub>16</sub>	7 <sup>5</sup> / <sub>8</sub>	<sup>3</sup> / <sub>4</sub>
USFB5000-307	3 <sup>7</sup> / <sub>16</sub>	8 <sup>3</sup> / <sub>8</sub>	6 <sup>23</sup> / <sub>32</sub>	9 <sup>1</sup> / <sub>2</sub>	3 <sup>7</sup> / <sub>32</sub>	1 <sup>1</sup> / <sub>8</sub>	4 <sup>1</sup> / <sub>2</sub>	4 <sup>15</sup> / <sub>32</sub>	5 <sup>5</sup> / <sub>16</sub>	7 <sup>5</sup> / <sub>8</sub>	<sup>3</sup> / <sub>4</sub>
USFB5000-308	3 <sup>1</sup> / <sub>2</sub>										
USFB5000-311	3 <sup>11</sup> / <sub>16</sub>										
USFB5000-315	3 <sup>15</sup> / <sub>16</sub>	9 <sup>1</sup> / <sub>2</sub>	7 <sup>19</sup> / <sub>32</sub>	10 <sup>3</sup> / <sub>4</sub>	3 <sup>1</sup> / <sub>2</sub>	1 <sup>1</sup> / <sub>8</sub>	4 <sup>31</sup> / <sub>32</sub>	4 <sup>15</sup> / <sub>16</sub>	6	8 <sup>3</sup> / <sub>8</sub>	<sup>7</sup> / <sub>8</sub>
USFB5000-400	4										

\* For expansion bearings, this dimension can increase by the corresponding value listed in Table 7 on page 27.

# Flange Block

## USFB5000A

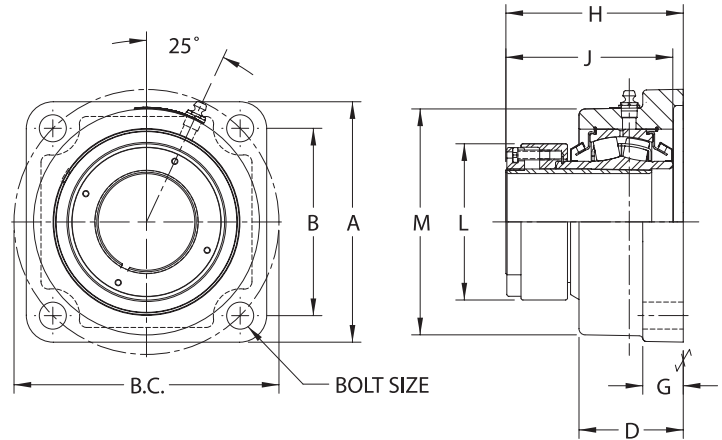

Four Bolt Base, Adapter Mount											
Nomenclature	Bore (INCHES)	A	B	B.C.	D	G	H*	J	L	M	Bolt Size
USFB5000A-107	1 7/16	4 5/8	3 17/32	5	2 1/16	3/4	3 3/8	3 23/64	2 47/64	3 7/8	1/2
USFB5000A-108	1 1/2	4 5/8	3 17/32	5	2 1/16	3/4	3 3/8	3 23/64	2 47/64	3 7/8	1/2
USFB5000A-111	1 11/16	5	3 57/64	5 1/2	2 1/4	3/4	3 31/64	3 29/64	2 63/64	4 1/2	1/2
USFB5000A-112	1 3/4	5	3 57/64	5 1/2	2 1/4	3/4	3 31/64	3 29/64	2 63/64	4 1/2	1/2
USFB5000A-115	1 15/16	5 3/16	4 1/16	5 3/4	2 1/4	3/4	3 17/32	3 1/2	3 3/16	4 3/4	1/2
USFB5000A-200	2	5 3/16	4 1/16	5 3/4	2 1/4	3/4	3 17/32	3 1/2	3 3/16	4 3/4	1/2
USFB5000A-203	2 3/16	5 7/8	4 1/2	6 3/8	2 7/16	13/16	3 29/32	3 57/64	3 29/64	5 1/8	5/8
USFB5000A-207	2 7/16	6 1/8	4 49/64	6 3/4	2 21/32	1 1/32	4 21/64	4 5/16	3 63/64	5 3/4	5/8
USFB5000A-208	2 1/2	6 1/8	4 49/64	6 3/4	2 21/32	1 1/32	4 21/64	4 5/16	3 63/64	5 3/4	5/8
USFB5000A-211	2 11/16	7 3/16	5 9/16	7 7/8	2 7/8	15/16	4 33/64	4 31/64	4 25/64	6 5/8	3/4
USFB5000A-212	2 3/4	7 3/16	5 9/16	7 7/8	2 7/8	15/16	4 33/64	4 31/64	4 25/64	6 5/8	3/4
USFB5000A-215	2 15/16	7 3/16	5 9/16	7 7/8	2 7/8	15/16	4 33/64	4 31/64	4 25/64	6 5/8	3/4
USFB5000A-300	3	7 3/16	5 9/16	7 7/8	2 7/8	15/16	4 33/64	4 31/64	4 25/64	6 5/8	3/4
USFB5000A-303	3 3/16	8 3/8	6 23/32	9 1/2	3 7/32	1 1/8	5 19/32	5 35/64	5 15/32	7 5/8	3/4
USFB5000A-307	3 7/16	8 3/8	6 23/32	9 1/2	3 7/32	1 1/8	5 19/32	5 35/64	5 15/32	7 5/8	3/4
USFB5000A-308	3 1/2	8 3/8	6 23/32	9 1/2	3 7/32	1 1/8	5 19/32	5 35/64	5 15/32	7 5/8	3/4
USFB5000A-311	3 11/16	9 1/2	7 19/32	10 3/4	3 1/2	1 1/8	5 63/64	5 15/16	5 13/16	8 3/8	7/8
USFB5000A-315	3 15/16	9 1/2	7 19/32	10 3/4	3 1/2	1 1/8	5 63/64	5 15/16	5 13/16	8 3/8	7/8
USFB5000A-400	4	9 1/2	7 19/32	10 3/4	3 1/2	1 1/8	5 63/64	5 15/16	5 13/16	8 3/8	7/8

\* For expansion bearings, this dimension can increase by the corresponding value listed in Table 7 on page 27.

# Flange Cartridge

## USFC5000

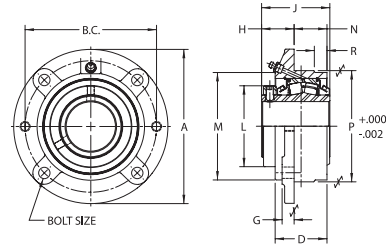

### Collar Mount

Nomenclature	Shaft Diameter (INCHES)	A	B.C.	D	G	H*	J	L	M	N	P	H	Bolt Size
USFC5000-107	1 7/16	5 1/4	4 3/8	2 1/16	15/32	1 7/16	2 3/4	2 49/64	3 1/2	1 9/32	3 5/8	-	3/8
USFC5000-108	1 1/2	5 1/4	4 3/8	2 1/16	15/32	1 7/16	2 3/4	2 49/64	3 1/2	1 9/32	3 5/8	-	3/8
USFC5000-111	1 11/16	6 1/8	5 1/8	2 1/4	15/32	1 27/64	2 7/8	2 3/4	4	1 7/16	4 1/4	9/16	7/16
USFC5000-112	1 3/4	6 1/8	5 1/8	2 1/4	15/32	1 27/64	2 7/8	2 3/4	4	1 7/16	4 1/4	9/16	7/16
USFC5000-115	1 15/16	6 3/8	5 3/8	2 1/4	17/32	1 25/64	2 7/8	3	4 3/8	1 15/32	4 1/2	19/32	7/16
USFC5000-200	2	6 3/8	5 3/8	2 1/4	17/32	1 25/64	2 7/8	3	4 3/8	1 15/32	4 1/2	19/32	7/16
USFC5000-203	2 3/16	7 1/8	6	2 3/8	17/32	1 37/64	3 1/8	3 1/4	4 3/4	1 15/32	5	15/32	1/2
USFC5000-207	2 7/16	7 5/8	6 1/2	2 9/16	19/32	1 19/32	3 3/8	4	5 5/16	1 5/8	5 1/2	5/8	1/2
USFC5000-208	2 1/2	7 5/8	6 1/2	2 9/16	19/32	1 19/32	3 3/8	4	5 5/16	1 5/8	5 1/2	5/8	1/2
USFC5000-211	2 11/16	8 3/4	7 1/2	2 7/8	23/32	1 63/64	3 7/8	4 17/32	6	1 27/32	6 3/8	19/32	5/8
USFC5000-212	2 3/4	8 3/4	7 1/2	2 7/8	23/32	1 63/64	3 7/8	4 17/32	6	1 27/32	6 3/8	19/32	5/8
USFC5000-215	2 15/16	8 3/4	7 1/2	2 7/8	23/32	1 63/64	3 7/8	4 17/32	6	1 27/32	6 3/8	19/32	5/8
USFC5000-300	3	8 3/4	7 1/2	2 7/8	23/32	1 63/64	3 7/8	4 17/32	6	1 27/32	6 3/8	19/32	5/8
USFC5000-303	3 3/16	10 1/4	8 5/8	3 7/64	53/64	2 13/32	4 15/32	5 5/16	7 3/16	1 27/32	7 3/8	19/32	3/4
USFC5000-307	3 7/16	10 1/4	8 5/8	3 7/64	53/64	2 13/32	4 15/32	5 5/16	7 3/16	1 27/32	7 3/8	19/32	3/4
USFC5000-308	3 1/2	10 1/4	8 5/8	3 7/64	53/64	2 13/32	4 15/32	5 5/16	7 3/16	1 27/32	7 3/8	19/32	3/4
USFC5000-311	3 11/16	10 7/8	9 3/8	3 1/2	31/32	2 21/32	4 15/16	6	7 3/4	2 1/16	8 1/8	9/16	3/4
USFC5000-315	3 15/16	10 7/8	9 3/8	3 1/2	31/32	2 21/32	4 15/16	6	7 3/4	2 1/16	8 1/8	9/16	3/4
USFC5000-400	4	10 7/8	9 3/8	3 1/2	31/32	2 21/32	4 15/16	6	7 3/4	2 1/16	8 1/8	9/16	3/4

\* For expansion bearings, this dimension can increase by the corresponding value listed in Table 7 on page 27.

# Flange Bracket

## USBF5000

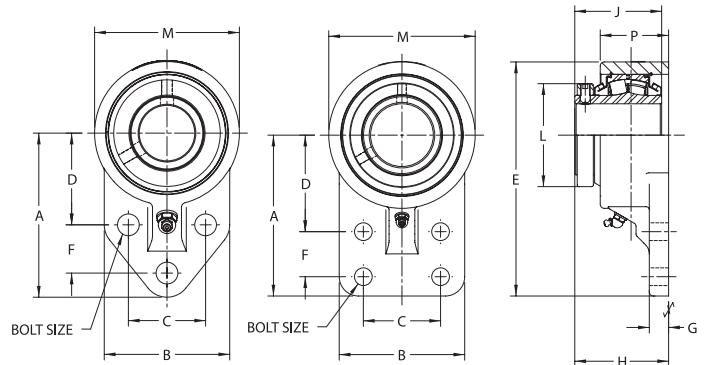
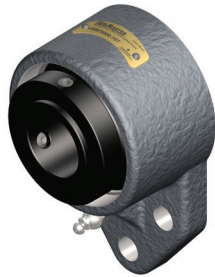

### Three Bolt, Collar Mount

Nomenclature	Shaft Diameter (INCHES)	A	B	C	D	E	F	G	H*	J	L	M	P	Bolt Size
USBF5000-107	1 7/16	4 1/4	3 1/4	2	2 3/8	6 1/8	1 1/4	5/8	2 25/32	2 3/4	2 49/64	3 3/4	2 1/4	1/2
USBF5000-115	1 15/16	5 3/16	4	2 3/4	2 15/16	7 5/16	1 5/8	9/16	2 29/32	2 7/8	3	4 1/4	2 1/4	1/2

### Four Bolt, Collar Mount

Nomenclature	Shaft Diameter (INCHES)	A	B	C	D	E	F	G	H*	J	L	M	P	Bolt Size
USBF5000-207	2 7/16	6 1/4	4 7/8	3	3 3/4	9 3/32	1 3/4	3/4	3 13/32	3 3/8	4	5 11/16	2 21/32	

\* For expansion bearings, this dimension can increase by the corresponding value listed in Table 7 on page 27.

## Flange Cartridge USFC5000A

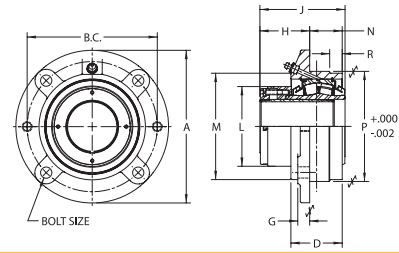

### Adapter Mount

Nomenclature	Shaft Diameter (INCHES)	A	B.C.	D	G	H*	J	L	M	N	P	H	Bolt Size
USFC5000-107	1 7/16	5 1/4	4 3/8	2 1/16	15/32	2 3/64	3 23/64	2 47/64	3 1/2	1 9/32	3 5/8	-	3/8
USFC5000-108	1 1/2	5 1/4	4 3/8	2 1/16	15/32	2 3/64	3 23/64	2 47/64	3 1/2	1 9/32	3 5/8	-	3/8
USFC5000-111	1 11/16	6 1/8	5 1/8	2 1/4	15/32	2	3 29/64	2 63/64	4	1 7/16	4 1/4	9/16	7/16
USFC5000-112	1 3/4	6 1/8	5 1/8	2 1/4	15/32	2	3 29/64	2 63/64	4	1 7/16	4 1/4	9/16	7/16
USFC5000-115	1 15/16	6 3/8	5 3/8	2 1/4	17/32	2 1/64	3 1/2	3 3/16	4 3/8	1 15/32	4 1/2	19/32	7/16
USFC5000-200	2	6 3/8	5 3/8	2 1/4	17/32	2 1/64	3 1/2	3 3/16	4 3/8	1 15/32	4 1/2	19/32	7/16
USFC5000-203	2 3/16	7 1/8	6	2 3/8	17/32	2 11/32	3 57/64	3 29/64	4 3/4	1 15/32	5	15/32	1/2
USFC5000-207	2 7/16	7 5/8	6 1/2	2 9/16	19/32	2 17/32	4 5/16	3 63/64	5 5/16	1 5/8	5 1/2	5/8	1/2
USFC5000-208	2 1/2	7 5/8	6 1/2	2 9/16	19/32	2 17/32	4 5/16	3 63/64	5 5/16	1 5/8	5 1/2	5/8	1/2
USFC5000-211	2 11/16	8 3/4	7 1/2	2 7/8	23/32	2 19/32	4 31/64	4 25/64	6	1 27/32	6 3/8	19/32	5/8
USFC5000-212	2 3/4	8 3/4	7 1/2	2 7/8	23/32	2 19/32	4 31/64	4 25/64	6	1 27/32	6 3/8	19/32	5/8
USFC5000-215	2 15/16	8 3/4	7 1/2	2 7/8	23/32	2 19/32	4 31/64	4 25/64	6	1 27/32	6 3/8	19/32	5/8
USFC5000-300	3	8 3/4	7 1/2	2 7/8	23/32	2 19/32	4 31/64	4 25/64	6	1 27/32	6 3/8	19/32	5/8
USFC5000-303	3 3/16	10 1/4	8 5/8	3 7/64	53/64	3 1/2	5 35/64	5 15/32	7 3/16	1 27/32	7 3/8	19/32	3/4
USFC5000A-307	3 7/16	10 1/4	8 5/8	3 7/64	53/64	3 1/2	5 35/64	5 15/32	7 3/16	1 27/32	7 3/8	19/32	3/4
USFC5000-308	3 1/2	10 1/4	8 5/8	3 7/64	53/64	3 1/2	5 35/64	5 15/32	7 3/16	1 27/32	7 3/8	19/32	3/4
USFC5000-311	3 11/16	10 7/8	9 3/8	3 1/2	31/32	3 21/32	5 15/16	5 13/16	7 3/4	2 1/16	8 1/8	9/16	3/4
USFC5000-315	3 15/16	10 7/8	9 3/8	3 1/2	31/32	3 21/32	5 15/16	5 13/16	7 3/4	2 1/16	8 1/8	9/16	3/4
USFC5000A-400	4	10 7/8	9 3/8	3 1/2	31/32	3 21/32	5 15/16	5 13/16	7 3/4	2 1/16	8 1/8	9/16	3/4

\* For expansion bearings, this dimension can increase by the corresponding value listed in Table 7 on page 27.

## Flange Bracket USBF5000A

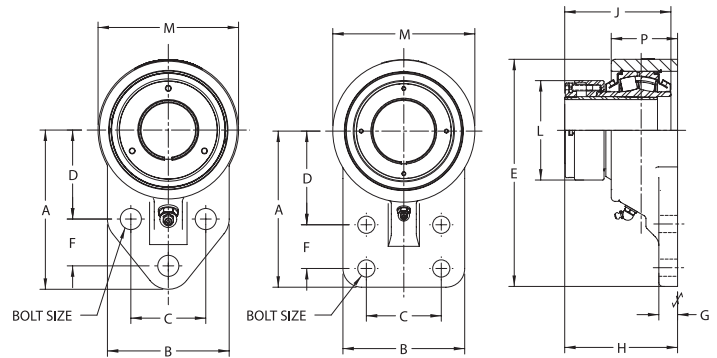
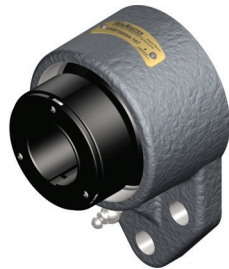

### Three Bolt, Collar Mount

Nomenclature	Shaft Diameter (INCHES)	A	B	C	D	E	F	G	H*	J	L	M	P	Bolt Size
USBF5000A-107	1 7/16	4 1/4	3 1/4	2	2 3/8	6 1/8	1 1/4	5/8	3 3/8	3 23/64	2 47/64	3 3/4	2 1/4	1/2
USBF5000A-115	1 15/16	5 3/16	4	2 3/4	2 15/16	7 5/16	1 5/8	9/16	3 17/32	3 1/2	3 3/16	4 1/4	2 1/4	1/2

### Four Bolt, Collar Mount

Nomenclature	Shaft Diameter (INCHES)	A	B	C	D	E	F	G	H*	J	L	M	P	Bolt Size
USBF5000A-207	2 7/16	6 1/4	4 7/8	3	3 3/4	9 3/32	1 3/4	3/4	4 21/64	4 5/16	3 63/64	5 11/16	2 21/32	5/8

\* For expansion bearings, this dimension can increase by the corresponding value listed in Table 7 on page 27.

**Take-Up**  
USTU5000

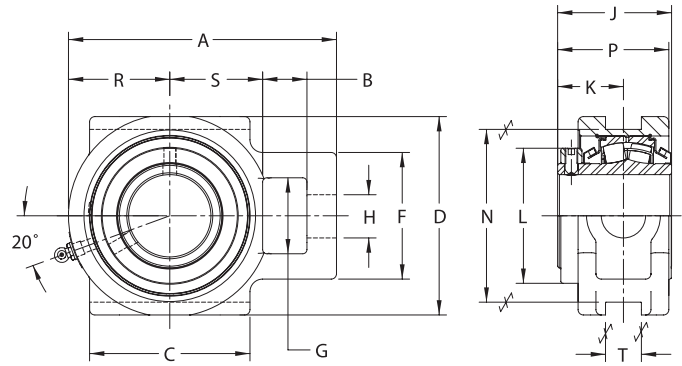
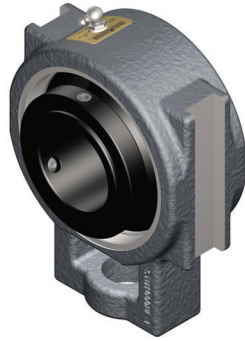

**Collar Mount**

Nomenclature	Shaft Diameter (INCHES)	A	B	C	D	F	G	H	J	K	L	N	P	R	S	T
USTU5000-115	1 15/16	6 3/16	1 1/16	3 1/2	4 3/4	2 7/8	1 15/16	1 1/16	2 7/8	1 11/16	3	4	2 29/32	2 1/4	2 1/8	11/16
USTU5000-200	2	6 3/16	1 1/16	3 1/2	4 3/4	2 7/8	1 15/16	1 1/16	2 7/8	1 11/16	3	4	2 29/32	2 1/4	2 1/8	11/16
USTU5000-203	2 3/16	6 13/16	1 3/16	3 3/4	5 1/4	3 1/2	2 1/4	1 3/16	3 1/8	1 55/64	3 1/4	4 1/2	3 9/64	2 1/2	2 3/8	13/16
USTU5000-207	2 7/16	7 15/16	1 5/16	4 3/4	5 7/8	3 3/4	2 1/4	1 5/16	3 3/8	1 15/16	4	5 1/8	3 9/32	3	2 3/4	1 1/16
USTU5000-208	2 1/2	7 15/16	1 5/16	4 3/4	5 7/8	3 3/4	2 1/4	1 5/16	3 3/8	1 15/16	4	5 1/8	3 9/32	3	2 3/4	1 1/16
USTU5000-211	2 11/16	8 3/4	1 9/16	4 3/4	6 3/4	4 1/4	2 3/4	1 9/16	3 7/8	2 11/32	4 17/32	5 15/16	3 27/32	3 3/16	3	1 13/16
USTU5000-212	2 3/4	8 3/4	1 9/16	4 3/4	6 3/4	4 1/4	2 3/4	1 9/16	3 7/8	2 11/32	4 17/32	5 15/16	3 27/32	3 3/16	3	1 13/16
USTU5000-215	2 15/16	8 3/4	1 9/16	4 3/4	6 3/4	4 1/4	2 3/4	1 9/16	3 7/8	2 11/32	4 17/32	5 15/16	3 27/32	3 3/16	3	1 13/16
USTU5000-300	3	8 3/4	1 9/16	4 3/4	6 3/4	4 1/4	2 3/4	1 9/16	3 7/8	2 11/32	4 17/32	5 15/16	3 27/32	3 3/16	3	1 13/16
USTU5000-303	3 3/16	10 7/16	1 13/16	6 1/4	7 5/8	4 7/8	2 7/8	1 13/16	4 15/32	2 41/64	5 5/16	6 13/16	4 29/64	4	3 5/8	1 13/16
USTU5000-307	3 7/16	10 7/16	1 13/16	6 1/4	7 5/8	4 7/8	2 7/8	1 13/16	4 15/32	2 41/64	5 5/16	6 13/16	4 29/64	4	3 5/8	1 13/16
USTU5000-308	3 1/2	10 7/16	1 13/16	6 1/4	7 5/8	4 7/8	2 7/8	1 13/16	4 15/32	2 41/64	5 5/16	6 13/16	4 29/64	4	3 5/8	1 13/16
USTU5000-311	3 11/16	11 13/16	2 1/8	7	9 7/16	5 5/8	3 3/8	2 3/16	4 15/16	2 59/64	6	8 5/8	5 11/64	4 7/16	4 1/8	2 1/16
USTU5000-315	3 15/16	11 13/16	2 1/8	7	9 7/16	5 5/8	3 3/8	2 3/16	4 15/16	2 59/64	6	8 5/8	5 11/64	4 7/16	4 1/8	2 1/16
USTU5000-400	4	11 13/16	2 1/8	7	9 7/16	5 5/8	3 3/8	2 3/16	4 15/16	2 59/64	6	8 5/8	5 11/64	4 7/16	4 1/8	2 1/16

**Take-Up**  
**USTU5000A**

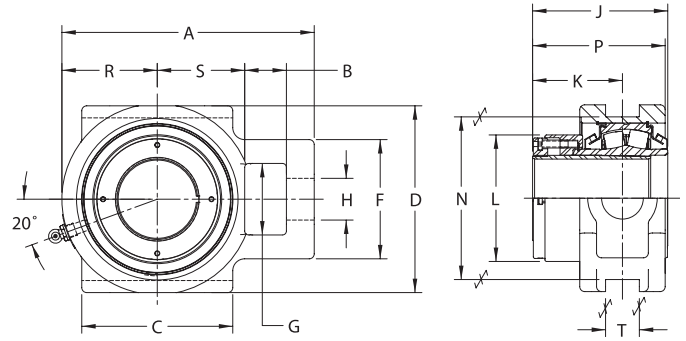
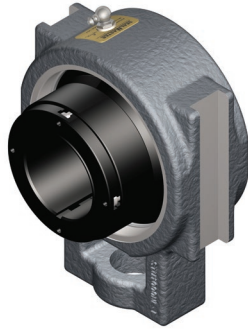

**Adapter Mount**

Nomenclature	Shaft Diameter (INCHES)	A	B	C	D	F	G	H	J	K	L	N	P	R	S	T
USTU5000A-115	1 15/16	6 3/16	1 1/16	3 1/2	4 3/4	2 7/8	1 15/16	1 1/16	3 1/2	2 5/16	3 3/16	4	3 17/32	2 1/4	2 1/8	11/16
USTU5000A-200	2	6 3/16	1 1/16	3 1/2	4 3/4	2 7/8	1 15/16	1 1/16	3 1/2	2 5/16	3 3/16	4	3 17/32	2 1/4	2 1/8	11/16
USTU5000A-203	2 3/16	6 13/16	1 3/16	3 3/4	5 1/4	3 1/2	2 1/4	1 3/16	3 57/64	2 5/8	3 29/64	4 1/2	3 29/32	2 1/2	2 3/8	13/16
USTU5000A-207	2 7/16	7 15/16	1 5/16	4 3/4	5 7/8	3 3/4	2 1/4	1 5/16	4 5/16	2 7/8	3 63/64	5 1/8	4 7/32	3	2 3/4	1 1/16
USTU5000A-208	2 1/2	7 15/16	1 5/16	4 3/4	5 7/8	3 3/4	2 1/4	1 5/16	4 5/16	2 7/8	3 63/64	5 1/8	4 7/32	3	2 3/4	1 1/16
USTU5000A-211	2 11/16															
USTU5000A-212	2 3/4	8 3/4	1 9/16	4 3/4	6 3/4	4 1/4	2 3/4	1 9/16	4 31/64	2 61/64	4 25/64	5 15/16	4 29/64	3 3/16	3	1 13/16
USTU5000A-215	2 15/16															
USTU5000A-300	3															
USTU5000A-303	3 3/16															
USTU5000A-307	3 7/16	10 7/16	1 13/16	6 1/4	7 5/8	4 7/8	2 7/8	1 13/16	5 35/64	3 47/64	5 15/32	6 13/16	5 35/64	4	3 5/8	1 13/16
USTU5000A-308	3 1/2															
USTU5000A-311	3 11/16															
USTU5000A-315	3 15/16	11 13/16	2 1/8	7	9 7/16	5 5/8	3 3/8	2 3/16	5 15/16	3 59/64	5 13/16	8 5/8	6 11/64	4 7/16	4 1/8	2 1/16
USTU5000A-400	4															

# Pillow Block

## USRBE5000

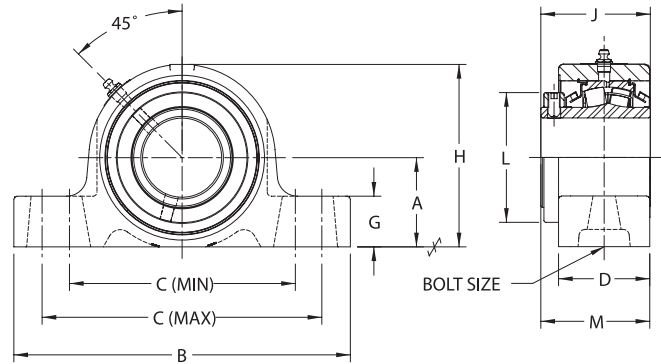
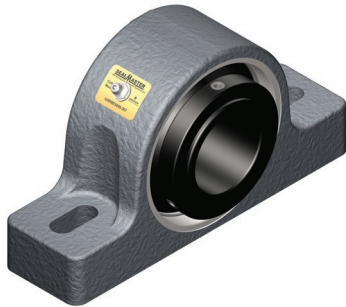

### Two Bolt Base, Collar Mount with Type E Dimensions

Nomenclature	Shaft Diameter (INCHES)	A	B	C		D	G	H	J	L	M*	Bolt Size
				MIN.	MAX.							
USRBE5000-115	1 15/16	2 1/4	8 7/8	6	7 1/8	2 7/16	1 5/16	4 17/32	2 7/8	3	2 63/64	5/8
USRBE5000-200	2	2 1/2	9 5/8	6 1/2	7 7/8	2 1/2	1 7/16	4 31/32	3 1/8	3 1/4	3 7/64	5/8
USRBE5000-203	2 3/16	2 1/2	9 5/8	6 1/2	7 7/8	2 1/2	1 7/16	4 31/32	3 1/8	3 1/4	3 7/64	5/8
USRBE5000-207	2 7/16	2 3/4	10 3/8	6 7/8	8 5/8	2 13/16	1 9/16	5 5/8	3 3/8	4	3 11/32	5/8
USRBE5000-208	2 1/2	2 3/4	10 3/8	6 7/8	8 5/8	2 13/16	1 9/16	5 5/8	3 3/8	4	3 11/32	5/8
USRBE5000-211	2 11/16	3 1/8	11 5/8	7 7/8	9 5/8	2 5/8	1 5/8	6 1/16	3 7/8	4 17/32	3 21/32	3/4
USRBE5000-212	2 3/4	3 1/8	11 5/8	7 7/8	9 5/8	2 5/8	1 5/8	6 1/16	3 7/8	4 17/32	3 21/32	3/4
USRBE5000-215	2 15/16	3 1/8	11 5/8	7 7/8	9 5/8	2 5/8	1 5/8	6 1/16	3 7/8	4 17/32	3 21/32	3/4
USRBE5000-300	3	3 3/4	13 1/2	9 3/8	11 1/4	3 1/8	2 1/16	7 3/8	4 15/32	5 5/16	4 13/64	7/8
USRBE5000-303	3 3/16	3 3/4	13 1/2	9 3/8	11 1/4	3 1/8	2 1/16	7 3/8	4 15/32	5 5/16	4 13/64	7/8
USRBE5000-307	3 7/16	3 3/4	13 1/2	9 3/8	11 1/4	3 1/8	2 1/16	7 3/8	4 15/32	5 5/16	4 13/64	7/8
USRBE5000-308	3 1/2	3 3/4	13 1/2	9 3/8	11 1/4	3 1/8	2 1/16	7 3/8	4 15/32	5 5/16	4 13/64	7/8
USRBE5000-311	3 11/16	4 1/8	14 1/4	10	11 3/4	3 9/16	2 1/4	8 1/2	4 15/16	6	4 23/32	1
USRBE5000-315	3 15/16	4 1/8	14 1/4	10	11 3/4	3 9/16	2 1/4	8 1/2	4 15/16	6	4 23/32	1
USRBE5000-400	4	4 1/8	14 1/4	10	11 3/4	3 9/16	2 1/4	8 1/2	4 15/16	6	4 23/32	1

Housings are ductile iron.

\* For expansion bearings, this dimension can increase by the corresponding value listed in Table 7 on page 27.

# Pillow Block

## USRBE5000A

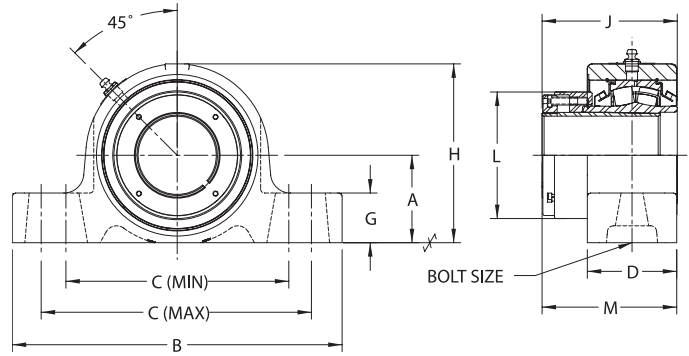
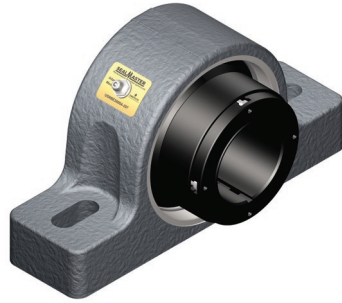

Two Bolt Base, Adapter Mount with Type E Dimensions												
Nomenclature	Shaft Diameter (INCHES)	A	B	C		D	G	H	J	L	M*	Bolt Size
				MIN.	MAX.							
USRBE5000A-115	1 15/16	2 1/4	8 7/8	6	7 1/8	2 7/16	1 5/16	4 17/32	3 1/2	3 3/16	3 19/32	5/8
USRBE5000A-200	2	2 1/2	9 5/8	6 1/2	7 7/8	2 1/2	1 7/16	4 31/32	3 57/64	3 29/64	3 7/8	5/8
USRBE5000A-203	2 3/16	2 1/2	9 5/8	6 1/2	7 7/8	2 1/2	1 7/16	4 31/32	3 57/64	3 29/64	3 7/8	5/8
USRBE5000A-207	2 7/16	2 3/4	10 3/8	6 7/8	8 5/8	2 13/16	1 9/16	5 5/8	4 5/16	3 63/64	4 19/64	5/8
USRBE5000A-208	2 1/2	2 3/4	10 3/8	6 7/8	8 5/8	2 13/16	1 9/16	5 5/8	4 5/16	3 63/64	4 19/64	5/8
USRBE5000A-211	2 11/16	3 1/8	11 5/8	7 7/8	9 5/8	2 5/8	1 5/8	6 1/16	4 31/64	4 25/64	4 17/64	3/4
USRBE5000A-212	2 3/4	3 1/8	11 5/8	7 7/8	9 5/8	2 5/8	1 5/8	6 1/16	4 31/64	4 25/64	4 17/64	3/4
USRBE5000A-215	2 15/16	3 1/8	11 5/8	7 7/8	9 5/8	2 5/8	1 5/8	6 1/16	4 31/64	4 25/64	4 17/64	3/4
USRBE5000A-300	3	3 1/8	11 5/8	7 7/8	9 5/8	2 5/8	1 5/8	6 1/16	4 31/64	4 25/64	4 17/64	3/4
USRBE5000A-303	3 3/16	3 3/4	13 1/2	9 3/8	11 1/4	3 1/8	2 1/16	7 3/8	5 35/64	5 15/32	5 19/64	7/8
USRBE5000A-307	3 7/16	3 3/4	13 1/2	9 3/8	11 1/4	3 1/8	2 1/16	7 3/8	5 35/64	5 15/32	5 19/64	7/8
USRBE5000A-308	3 1/2	3 3/4	13 1/2	9 3/8	11 1/4	3 1/8	2 1/16	7 3/8	5 35/64	5 15/32	5 19/64	7/8
USRBE5000A-311	3 11/16	4 1/8	14 1/4	10	11 3/4	3 9/16	2 1/4	8 1/2	5 15/16	5 13/16	5 23/32	1
USRBE5000A-315	3 15/16	4 1/8	14 1/4	10	11 3/4	3 9/16	2 1/4	8 1/2	5 15/16	5 13/16	5 23/32	1
USRBE5000A-400	4	4 1/8	14 1/4	10	11 3/4	3 9/16	2 1/4	8 1/2	5 15/16	5 13/16	5 23/32	1

Housings are ductile iron.

\* For expansion bearings, this dimension can increase by the corresponding value listed in Table 7 on page 27.

# Flange Block

## USFBE5000

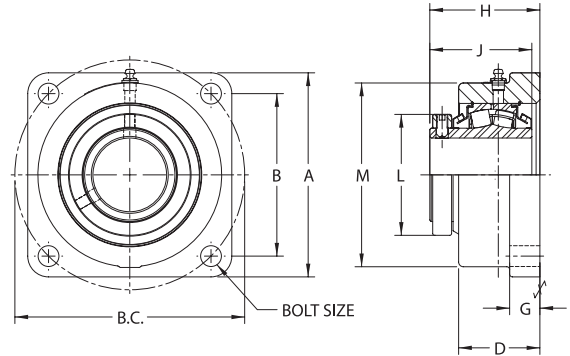

### Four Bolt Base, Collar Mount with Type E Dimensions

Nomenclature	Shaft Diameter (INCHES)	A	B	B.C.	D	G	H*	J	L	M	Bolt Size
USFBE5000-115	1 <sup>15</sup> / <sub>16</sub>	5 1/2	4 <sup>3</sup> / <sub>8</sub>	6 <sup>3</sup> / <sub>16</sub>	2 <sup>9</sup> / <sub>16</sub>	7/8	2 <sup>29</sup> / <sub>32</sub>	2 <sup>7</sup> / <sub>8</sub>	3	4 <sup>31</sup> / <sub>32</sub>	1/2
USFBE5000-200	2	6 <sup>3</sup> / <sub>16</sub>	4 <sup>7</sup> / <sub>8</sub>	6 <sup>57</sup> / <sub>64</sub>	2 <sup>5</sup> / <sub>8</sub>	1	3 <sup>5</sup> / <sub>32</sub>	3 <sup>1</sup> / <sub>8</sub>	3 <sup>1</sup> / <sub>4</sub>	5 <sup>15</sup> / <sub>32</sub>	5/8
USFBE5000-207	2 <sup>7</sup> / <sub>16</sub>	6 <sup>3</sup> / <sub>4</sub>	5 <sup>3</sup> / <sub>8</sub>	7 <sup>19</sup> / <sub>32</sub>	2 <sup>11</sup> / <sub>16</sub>	1	3 <sup>13</sup> / <sub>32</sub>	3 <sup>3</sup> / <sub>8</sub>	4	6 <sup>3</sup> / <sub>32</sub>	5/8
USFBE5000-208	2 1/2										
USFBE5000-211	2 <sup>11</sup> / <sub>16</sub>										
USFBE5000-212	2 <sup>3</sup> / <sub>4</sub>	7 <sup>5</sup> / <sub>8</sub>	6	8 <sup>31</sup> / <sub>64</sub>	2 <sup>3</sup> / <sub>4</sub>	1 <sup>1</sup> / <sub>16</sub>	3 <sup>57</sup> / <sub>64</sub>	3 <sup>7</sup> / <sub>8</sub>	4 <sup>17</sup> / <sub>32</sub>	6 <sup>53</sup> / <sub>64</sub>	3/4
USFBE5000-215	2 <sup>15</sup> / <sub>16</sub>										
USFBE5000-300	3										
USFBE5000-303	3 <sup>3</sup> / <sub>16</sub>										
USFBE5000-307	3 <sup>7</sup> / <sub>16</sub>	8 <sup>5</sup> / <sub>8</sub>	7	9 <sup>29</sup> / <sub>32</sub>	3 <sup>1</sup> / <sub>4</sub>	1 <sup>1</sup> / <sub>4</sub>	4 <sup>33</sup> / <sub>64</sub>	4 <sup>15</sup> / <sub>32</sub>	5 <sup>5</sup> / <sub>16</sub>	7 <sup>31</sup> / <sub>32</sub>	3/4
USFBE5000-308	3 1/2										
USFBE5000-311	3 <sup>11</sup> / <sub>16</sub>										
USFBE5000-315	3 <sup>15</sup> / <sub>16</sub>	9 1/2	7 <sup>19</sup> / <sub>32</sub>	10 <sup>3</sup> / <sub>4</sub>	3 <sup>11</sup> / <sub>16</sub>	1 <sup>1</sup> / <sub>4</sub>	4 <sup>31</sup> / <sub>32</sub>	4 <sup>15</sup> / <sub>16</sub>	6	8 <sup>27</sup> / <sub>64</sub>	7/8
USFBE5000-400	4										

Housings are ductile iron.

\* For expansion bearings, this dimension can increase by the corresponding value listed in Table 7 on page 27.

# Flange Block

## USFBE5000A

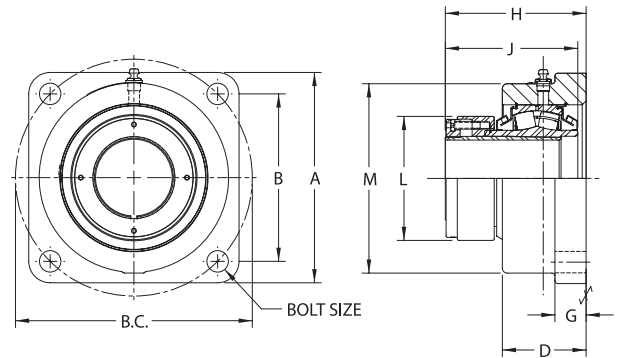

Four Bolt Base, Adapter Mount with Type E Dimensions											
Nomenclature	Shaft Diameter (INCHES)	A	B	B.C.	D	G	H*	J	L	M	Bolt Size
USFBE5000A-115	1 <sup>15</sup> / <sub>16</sub>	5 <sup>1</sup> / <sub>2</sub>	4 <sup>3</sup> / <sub>8</sub>	6 <sup>3</sup> / <sub>16</sub>	2 <sup>9</sup> / <sub>16</sub>	<sup>7</sup> / <sub>8</sub>	3 <sup>17</sup> / <sub>32</sub>	3 <sup>1</sup> / <sub>2</sub>	3 <sup>3</sup> / <sub>16</sub>	4 <sup>31</sup> / <sub>32</sub>	<sup>1</sup> / <sub>2</sub>
USFBE5000A-200	2	5 <sup>1</sup> / <sub>2</sub>	4 <sup>3</sup> / <sub>8</sub>	6 <sup>3</sup> / <sub>16</sub>	2 <sup>9</sup> / <sub>16</sub>	<sup>7</sup> / <sub>8</sub>	3 <sup>17</sup> / <sub>32</sub>	3 <sup>1</sup> / <sub>2</sub>	3 <sup>3</sup> / <sub>16</sub>	4 <sup>31</sup> / <sub>32</sub>	<sup>1</sup> / <sub>2</sub>
USFBE5000A-203	2 <sup>3</sup> / <sub>16</sub>	6 <sup>3</sup> / <sub>16</sub>	4 <sup>7</sup> / <sub>8</sub>	6 <sup>57</sup> / <sub>64</sub>	2 <sup>5</sup> / <sub>8</sub>	1	3 <sup>29</sup> / <sub>32</sub>	3 <sup>57</sup> / <sub>64</sub>	3 <sup>29</sup> / <sub>64</sub>	5 <sup>15</sup> / <sub>32</sub>	<sup>5</sup> / <sub>8</sub>
USFBE5000A-207	2 <sup>7</sup> / <sub>16</sub>	6 <sup>3</sup> / <sub>4</sub>	5 <sup>3</sup> / <sub>8</sub>	7 <sup>19</sup> / <sub>32</sub>	2 <sup>11</sup> / <sub>16</sub>	1	4 <sup>21</sup> / <sub>64</sub>	4 <sup>5</sup> / <sub>16</sub>	3 <sup>63</sup> / <sub>64</sub>	6 <sup>3</sup> / <sub>32</sub>	<sup>5</sup> / <sub>8</sub>
USFBE5000A-208	2 <sup>1</sup> / <sub>2</sub>	6 <sup>3</sup> / <sub>4</sub>	5 <sup>3</sup> / <sub>8</sub>	7 <sup>19</sup> / <sub>32</sub>	2 <sup>11</sup> / <sub>16</sub>	1	4 <sup>21</sup> / <sub>64</sub>	4 <sup>5</sup> / <sub>16</sub>	3 <sup>63</sup> / <sub>64</sub>	6 <sup>3</sup> / <sub>32</sub>	<sup>5</sup> / <sub>8</sub>
USFBE5000A-211	2 <sup>11</sup> / <sub>16</sub>										
USFBE5000A-212	2 <sup>3</sup> / <sub>4</sub>	7 <sup>5</sup> / <sub>8</sub>	6	8 <sup>31</sup> / <sub>64</sub>	2 <sup>3</sup> / <sub>4</sub>	1 <sup>1</sup> / <sub>16</sub>	4 <sup>33</sup> / <sub>64</sub>	4 <sup>31</sup> / <sub>64</sub>	4 <sup>25</sup> / <sub>64</sub>	6 <sup>53</sup> / <sub>64</sub>	<sup>3</sup> / <sub>4</sub>
USFBE5000A-215	2 <sup>15</sup> / <sub>16</sub>	7 <sup>5</sup> / <sub>8</sub>	6	8 <sup>31</sup> / <sub>64</sub>	2 <sup>3</sup> / <sub>4</sub>	1 <sup>1</sup> / <sub>16</sub>	4 <sup>33</sup> / <sub>64</sub>	4 <sup>31</sup> / <sub>64</sub>	4 <sup>25</sup> / <sub>64</sub>	6 <sup>53</sup> / <sub>64</sub>	<sup>3</sup> / <sub>4</sub>
USFBE5000A-300	3										
USFBE5000A-303	3 <sup>3</sup> / <sub>16</sub>	8 <sup>5</sup> / <sub>8</sub>	7	9 <sup>29</sup> / <sub>32</sub>	3 <sup>1</sup> / <sub>4</sub>	1 <sup>1</sup> / <sub>4</sub>	5 <sup>19</sup> / <sub>32</sub>	5 <sup>35</sup> / <sub>64</sub>	5 <sup>15</sup> / <sub>32</sub>	7 <sup>31</sup> / <sub>32</sub>	<sup>3</sup> / <sub>4</sub>
USFBE5000A-307	3 <sup>7</sup> / <sub>16</sub>	8 <sup>5</sup> / <sub>8</sub>	7	9 <sup>29</sup> / <sub>32</sub>	3 <sup>1</sup> / <sub>4</sub>	1 <sup>1</sup> / <sub>4</sub>	5 <sup>19</sup> / <sub>32</sub>	5 <sup>35</sup> / <sub>64</sub>	5 <sup>15</sup> / <sub>32</sub>	7 <sup>31</sup> / <sub>32</sub>	<sup>3</sup> / <sub>4</sub>
USFBE5000A-308	3 <sup>1</sup> / <sub>2</sub>	8 <sup>5</sup> / <sub>8</sub>	7	9 <sup>29</sup> / <sub>32</sub>	3 <sup>1</sup> / <sub>4</sub>	1 <sup>1</sup> / <sub>4</sub>	5 <sup>19</sup> / <sub>32</sub>	5 <sup>35</sup> / <sub>64</sub>	5 <sup>15</sup> / <sub>32</sub>	7 <sup>31</sup> / <sub>32</sub>	<sup>3</sup> / <sub>4</sub>
USFBE5000A-311	3 <sup>11</sup> / <sub>16</sub>										
USFBE5000A-315	3 <sup>15</sup> / <sub>16</sub>	9 <sup>1</sup> / <sub>2</sub>	7 <sup>19</sup> / <sub>32</sub>	10 <sup>3</sup> / <sub>4</sub>	3 <sup>11</sup> / <sub>16</sub>	1 <sup>1</sup> / <sub>4</sub>	5 <sup>63</sup> / <sub>64</sub>	5 <sup>15</sup> / <sub>16</sub>	5 <sup>13</sup> / <sub>16</sub>	8 <sup>27</sup> / <sub>64</sub>	<sup>7</sup> / <sub>8</sub>
USFBE5000A-400	4										

Housings are ductile iron.

\* For expansion bearings, this dimension can increase by the corresponding value listed in Table 7 on page 27.

# Flange Cartridge

## USFCE5000

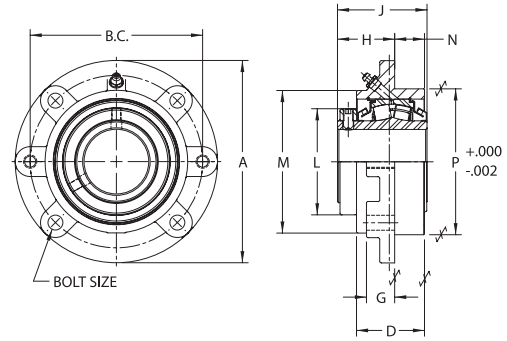

### Collar Mount with Type E Dimensions

Nomenclature	Shaft Diameter (INCHES)	A	B.C.	D	G	H*	J	L	M	N	P	Bolt Size
USFCE5000-115	1 <sup>15</sup> / <sub>16</sub>	6 <sup>3</sup> / <sub>8</sub>	5 <sup>3</sup> / <sub>8</sub>	2 <sup>7</sup> / <sub>16</sub>	1	1 <sup>57</sup> / <sub>64</sub>	2 <sup>7</sup> / <sub>8</sub>	3	4 <sup>1</sup> / <sub>2</sub>	1 <sup>1</sup> / <sub>16</sub>	4 <sup>1</sup> / <sub>2</sub>	<sup>3</sup> / <sub>8</sub>
USFCE5000-200	2	7 <sup>1</sup> / <sub>8</sub>	6	2 <sup>1</sup> / <sub>2</sub>	1	1 <sup>63</sup> / <sub>64</sub>	3 <sup>1</sup> / <sub>8</sub>	3 <sup>1</sup> / <sub>4</sub>	4 <sup>7</sup> / <sub>8</sub>	1 <sup>1</sup> / <sub>8</sub>	5	<sup>1</sup> / <sub>2</sub>
USFCE5000-207	2 <sup>7</sup> / <sub>16</sub>	7 <sup>5</sup> / <sub>8</sub>	6 <sup>1</sup> / <sub>2</sub>	2 <sup>9</sup> / <sub>16</sub>	1 <sup>1</sup> / <sub>16</sub>	2 <sup>9</sup> / <sub>64</sub>	3 <sup>3</sup> / <sub>8</sub>	4	5 <sup>3</sup> / <sub>8</sub>	1 <sup>1</sup> / <sub>8</sub>	5 <sup>1</sup> / <sub>2</sub>	<sup>1</sup> / <sub>2</sub>
USFCE5000-208	2 <sup>1</sup> / <sub>2</sub>	7 <sup>5</sup> / <sub>8</sub>	6 <sup>1</sup> / <sub>2</sub>	2 <sup>9</sup> / <sub>16</sub>	1 <sup>1</sup> / <sub>16</sub>	2 <sup>9</sup> / <sub>64</sub>	3 <sup>3</sup> / <sub>8</sub>	4	5 <sup>3</sup> / <sub>8</sub>	1 <sup>1</sup> / <sub>8</sub>	5 <sup>1</sup> / <sub>2</sub>	<sup>1</sup> / <sub>2</sub>
USFCE5000-211	2 <sup>11</sup> / <sub>16</sub>	8 <sup>3</sup> / <sub>4</sub>	7 <sup>1</sup> / <sub>2</sub>	2 <sup>9</sup> / <sub>16</sub>	<sup>15</sup> / <sub>16</sub>	2 <sup>27</sup> / <sub>64</sub>	3 <sup>7</sup> / <sub>8</sub>	4 <sup>17</sup> / <sub>32</sub>	6 <sup>1</sup> / <sub>4</sub>	1 <sup>1</sup> / <sub>4</sub>	6 <sup>3</sup> / <sub>8</sub>	<sup>5</sup> / <sub>8</sub>
USFCE5000-212	2 <sup>3</sup> / <sub>4</sub>	8 <sup>3</sup> / <sub>4</sub>	7 <sup>1</sup> / <sub>2</sub>	2 <sup>9</sup> / <sub>16</sub>	<sup>15</sup> / <sub>16</sub>	2 <sup>27</sup> / <sub>64</sub>	3 <sup>7</sup> / <sub>8</sub>	4 <sup>17</sup> / <sub>32</sub>	6 <sup>1</sup> / <sub>4</sub>	1 <sup>1</sup> / <sub>4</sub>	6 <sup>3</sup> / <sub>8</sub>	<sup>5</sup> / <sub>8</sub>
USFCE5000-215	2 <sup>15</sup> / <sub>16</sub>	8 <sup>3</sup> / <sub>4</sub>	7 <sup>1</sup> / <sub>2</sub>	2 <sup>9</sup> / <sub>16</sub>	<sup>15</sup> / <sub>16</sub>	2 <sup>27</sup> / <sub>64</sub>	3 <sup>7</sup> / <sub>8</sub>	4 <sup>17</sup> / <sub>32</sub>	6 <sup>1</sup> / <sub>4</sub>	1 <sup>1</sup> / <sub>4</sub>	6 <sup>3</sup> / <sub>8</sub>	<sup>5</sup> / <sub>8</sub>
USFCE5000-300	3	10 <sup>1</sup> / <sub>4</sub>	8 <sup>5</sup> / <sub>8</sub>	3 <sup>1</sup> / <sub>8</sub>	1 <sup>7</sup> / <sub>16</sub>	2 <sup>15</sup> / <sub>16</sub>	4 <sup>15</sup> / <sub>32</sub>	5 <sup>5</sup> / <sub>16</sub>	7 <sup>1</sup> / <sub>8</sub>	1 <sup>5</sup> / <sub>16</sub>	7 <sup>3</sup> / <sub>8</sub>	<sup>3</sup> / <sub>4</sub>
USFCE5000-303	3 <sup>3</sup> / <sub>16</sub>	10 <sup>1</sup> / <sub>4</sub>	8 <sup>5</sup> / <sub>8</sub>	3 <sup>1</sup> / <sub>8</sub>	1 <sup>7</sup> / <sub>16</sub>	2 <sup>15</sup> / <sub>16</sub>	4 <sup>15</sup> / <sub>32</sub>	5 <sup>5</sup> / <sub>16</sub>	7 <sup>1</sup> / <sub>8</sub>	1 <sup>5</sup> / <sub>16</sub>	7 <sup>3</sup> / <sub>8</sub>	<sup>3</sup> / <sub>4</sub>
USFCE5000-307	3 <sup>7</sup> / <sub>16</sub>	10 <sup>1</sup> / <sub>4</sub>	8 <sup>5</sup> / <sub>8</sub>	3 <sup>1</sup> / <sub>8</sub>	1 <sup>7</sup> / <sub>16</sub>	2 <sup>15</sup> / <sub>16</sub>	4 <sup>15</sup> / <sub>32</sub>	5 <sup>5</sup> / <sub>16</sub>	7 <sup>1</sup> / <sub>8</sub>	1 <sup>5</sup> / <sub>16</sub>	7 <sup>3</sup> / <sub>8</sub>	<sup>3</sup> / <sub>4</sub>
USFCE5000-308	3 <sup>1</sup> / <sub>2</sub>	10 <sup>1</sup> / <sub>4</sub>	8 <sup>5</sup> / <sub>8</sub>	3 <sup>1</sup> / <sub>8</sub>	1 <sup>7</sup> / <sub>16</sub>	2 <sup>15</sup> / <sub>16</sub>	4 <sup>15</sup> / <sub>32</sub>	5 <sup>5</sup> / <sub>16</sub>	7 <sup>1</sup> / <sub>8</sub>	1 <sup>5</sup> / <sub>16</sub>	7 <sup>3</sup> / <sub>8</sub>	<sup>3</sup> / <sub>4</sub>
USFCE5000-311	3 <sup>11</sup> / <sub>16</sub>	10 <sup>7</sup> / <sub>8</sub>	9 <sup>3</sup> / <sub>8</sub>	3 <sup>1</sup> / <sub>2</sub>	1 <sup>1</sup> / <sub>16</sub>	2 <sup>21</sup> / <sub>32</sub>	4 <sup>15</sup> / <sub>16</sub>	6	7 <sup>3</sup> / <sub>4</sub>	2 <sup>1</sup> / <sub>16</sub>	8 <sup>1</sup> / <sub>8</sub>	<sup>3</sup> / <sub>4</sub>
USFCE5000-315	3 <sup>15</sup> / <sub>16</sub>	10 <sup>7</sup> / <sub>8</sub>	9 <sup>3</sup> / <sub>8</sub>	3 <sup>1</sup> / <sub>2</sub>	1 <sup>1</sup> / <sub>16</sub>	2 <sup>21</sup> / <sub>32</sub>	4 <sup>15</sup> / <sub>16</sub>	6	7 <sup>3</sup> / <sub>4</sub>	2 <sup>1</sup> / <sub>16</sub>	8 <sup>1</sup> / <sub>8</sub>	<sup>3</sup> / <sub>4</sub>
USFCE5000-400	4	10 <sup>7</sup> / <sub>8</sub>	9 <sup>3</sup> / <sub>8</sub>	3 <sup>1</sup> / <sub>2</sub>	1 <sup>1</sup> / <sub>16</sub>	2 <sup>21</sup> / <sub>32</sub>	4 <sup>15</sup> / <sub>16</sub>	6	7 <sup>3</sup> / <sub>4</sub>	2 <sup>1</sup> / <sub>16</sub>	8 <sup>1</sup> / <sub>8</sub>	<sup>3</sup> / <sub>4</sub>

Housings are ductile iron.

\* For expansion bearings, this dimension can increase by the corresponding value listed in Table 7 on page 27.

# Flange Cartridge

## USFCE5000A

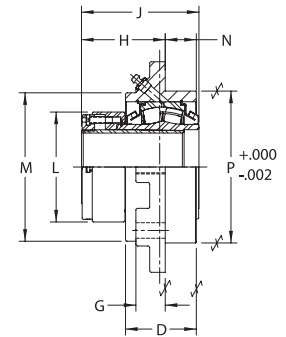
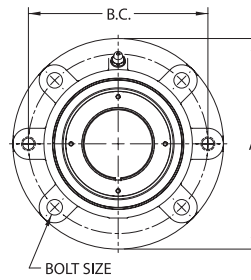

### Adapter Mount with Type E Dimensions

Nomenclature	Shaft Diameter (INCHES)	A	B.C.	D	G	H*	J	L	M	N	P	Bolt Size
USFCE5000A-115	1 <sup>15</sup> / <sub>16</sub>	6 <sup>3</sup> / <sub>8</sub>	5 <sup>3</sup> / <sub>8</sub>	2 <sup>7</sup> / <sub>16</sub>	1	2 <sup>39</sup> / <sub>64</sub>	3 <sup>1</sup> / <sub>2</sub>	3 <sup>3</sup> / <sub>16</sub>	4 <sup>1</sup> / <sub>2</sub>	1 <sup>1</sup> / <sub>16</sub>	4 <sup>1</sup> / <sub>2</sub>	<sup>3</sup> / <sub>8</sub>
USFCE5000A-200	2	7 <sup>1</sup> / <sub>8</sub>	6	2 <sup>1</sup> / <sub>2</sub>	1	2 <sup>3</sup> / <sub>4</sub>	3 <sup>57</sup> / <sub>64</sub>	3 <sup>29</sup> / <sub>64</sub>	4 <sup>7</sup> / <sub>8</sub>	1 <sup>1</sup> / <sub>8</sub>	5	<sup>1</sup> / <sub>2</sub>
USFCE5000A-203	2 <sup>7</sup> / <sub>16</sub>	7 <sup>5</sup> / <sub>8</sub>	6 <sup>1</sup> / <sub>2</sub>	2 <sup>9</sup> / <sub>16</sub>	1 <sup>1</sup> / <sub>16</sub>	3 <sup>5</sup> / <sub>64</sub>	4 <sup>5</sup> / <sub>16</sub>	3 <sup>63</sup> / <sub>64</sub>	5 <sup>3</sup> / <sub>8</sub>	1 <sup>1</sup> / <sub>8</sub>	5 <sup>1</sup> / <sub>2</sub>	<sup>1</sup> / <sub>2</sub>
USFCE5000A-208	2 <sup>1</sup> / <sub>2</sub>	7 <sup>5</sup> / <sub>8</sub>	6 <sup>1</sup> / <sub>2</sub>	2 <sup>9</sup> / <sub>16</sub>	1 <sup>1</sup> / <sub>16</sub>	3 <sup>5</sup> / <sub>64</sub>	4 <sup>5</sup> / <sub>16</sub>	3 <sup>63</sup> / <sub>64</sub>	5 <sup>3</sup> / <sub>8</sub>	1 <sup>1</sup> / <sub>8</sub>	5 <sup>1</sup> / <sub>2</sub>	<sup>1</sup> / <sub>2</sub>
USFCE5000A-211	2 <sup>11</sup> / <sub>16</sub>	8 <sup>3</sup> / <sub>4</sub>	7 <sup>1</sup> / <sub>2</sub>	2 <sup>9</sup> / <sub>16</sub>	<sup>15</sup> / <sub>16</sub>	3 <sup>3</sup> / <sub>64</sub>	4 <sup>31</sup> / <sub>64</sub>	4 <sup>25</sup> / <sub>64</sub>	6 <sup>1</sup> / <sub>4</sub>	1 <sup>1</sup> / <sub>4</sub>	6 <sup>3</sup> / <sub>8</sub>	<sup>5</sup> / <sub>8</sub>
USFCE5000A-212	2 <sup>3</sup> / <sub>4</sub>	8 <sup>3</sup> / <sub>4</sub>	7 <sup>1</sup> / <sub>2</sub>	2 <sup>9</sup> / <sub>16</sub>	<sup>15</sup> / <sub>16</sub>	3 <sup>3</sup> / <sub>64</sub>	4 <sup>31</sup> / <sub>64</sub>	4 <sup>25</sup> / <sub>64</sub>	6 <sup>1</sup> / <sub>4</sub>	1 <sup>1</sup> / <sub>4</sub>	6 <sup>3</sup> / <sub>8</sub>	<sup>5</sup> / <sub>8</sub>
USFCE5000A-215	2 <sup>15</sup> / <sub>16</sub>	8 <sup>3</sup> / <sub>4</sub>	7 <sup>1</sup> / <sub>2</sub>	2 <sup>9</sup> / <sub>16</sub>	<sup>15</sup> / <sub>16</sub>	3 <sup>3</sup> / <sub>64</sub>	4 <sup>31</sup> / <sub>64</sub>	4 <sup>25</sup> / <sub>64</sub>	6 <sup>1</sup> / <sub>4</sub>	1 <sup>1</sup> / <sub>4</sub>	6 <sup>3</sup> / <sub>8</sub>	<sup>5</sup> / <sub>8</sub>
USFCE5000A-300	3	10 <sup>1</sup> / <sub>4</sub>	8 <sup>5</sup> / <sub>8</sub>	3 <sup>1</sup> / <sub>8</sub>	1 <sup>7</sup> / <sub>16</sub>	4 <sup>1</sup> / <sub>32</sub>	5 <sup>35</sup> / <sub>64</sub>	5 <sup>15</sup> / <sub>32</sub>	7 <sup>1</sup> / <sub>8</sub>	1 <sup>5</sup> / <sub>16</sub>	7 <sup>3</sup> / <sub>8</sub>	<sup>3</sup> / <sub>4</sub>
USFCE5000A-303	3 <sup>3</sup> / <sub>16</sub>	10 <sup>1</sup> / <sub>4</sub>	8 <sup>5</sup> / <sub>8</sub>	3 <sup>1</sup> / <sub>8</sub>	1 <sup>7</sup> / <sub>16</sub>	4 <sup>1</sup> / <sub>32</sub>	5 <sup>35</sup> / <sub>64</sub>	5 <sup>15</sup> / <sub>32</sub>	7 <sup>1</sup> / <sub>8</sub>	1 <sup>5</sup> / <sub>16</sub>	7 <sup>3</sup> / <sub>8</sub>	<sup>3</sup> / <sub>4</sub>
USFCE5000A-307	3 <sup>7</sup> / <sub>16</sub>	10 <sup>1</sup> / <sub>4</sub>	8 <sup>5</sup> / <sub>8</sub>	3 <sup>1</sup> / <sub>8</sub>	1 <sup>7</sup> / <sub>16</sub>	4 <sup>1</sup> / <sub>32</sub>	5 <sup>35</sup> / <sub>64</sub>	5 <sup>15</sup> / <sub>32</sub>	7 <sup>1</sup> / <sub>8</sub>	1 <sup>5</sup> / <sub>16</sub>	7 <sup>3</sup> / <sub>8</sub>	<sup>3</sup> / <sub>4</sub>
USFCE5000A-308	3 <sup>1</sup> / <sub>2</sub>	10 <sup>1</sup> / <sub>4</sub>	8 <sup>5</sup> / <sub>8</sub>	3 <sup>1</sup> / <sub>8</sub>	1 <sup>7</sup> / <sub>16</sub>	4 <sup>1</sup> / <sub>32</sub>	5 <sup>35</sup> / <sub>64</sub>	5 <sup>15</sup> / <sub>32</sub>	7 <sup>1</sup> / <sub>8</sub>	1 <sup>5</sup> / <sub>16</sub>	7 <sup>3</sup> / <sub>8</sub>	<sup>3</sup> / <sub>4</sub>
USFCE5000A-311	3 <sup>11</sup> / <sub>16</sub>	10 <sup>7</sup> / <sub>8</sub>	9 <sup>3</sup> / <sub>8</sub>	3 <sup>1</sup> / <sub>2</sub>	1 <sup>1</sup> / <sub>16</sub>	3 <sup>21</sup> / <sub>32</sub>	5 <sup>15</sup> / <sub>16</sub>	5 <sup>13</sup> / <sub>16</sub>	7 <sup>3</sup> / <sub>4</sub>	2 <sup>1</sup> / <sub>16</sub>	8 <sup>1</sup> / <sub>8</sub>	<sup>3</sup> / <sub>4</sub>
USFCE5000A-315	3 <sup>15</sup> / <sub>16</sub>	10 <sup>7</sup> / <sub>8</sub>	9 <sup>3</sup> / <sub>8</sub>	3 <sup>1</sup> / <sub>2</sub>	1 <sup>1</sup> / <sub>16</sub>	3 <sup>21</sup> / <sub>32</sub>	5 <sup>15</sup> / <sub>16</sub>	5 <sup>13</sup> / <sub>16</sub>	7 <sup>3</sup> / <sub>4</sub>	2 <sup>1</sup> / <sub>16</sub>	8 <sup>1</sup> / <sub>8</sub>	<sup>3</sup> / <sub>4</sub>
USFCE5000A-400	4	10 <sup>7</sup> / <sub>8</sub>	9 <sup>3</sup> / <sub>8</sub>	3 <sup>1</sup> / <sub>2</sub>	1 <sup>1</sup> / <sub>16</sub>	3 <sup>21</sup> / <sub>32</sub>	5 <sup>15</sup> / <sub>16</sub>	5 <sup>13</sup> / <sub>16</sub>	7 <sup>3</sup> / <sub>4</sub>	2 <sup>1</sup> / <sub>16</sub>	8 <sup>1</sup> / <sub>8</sub>	<sup>3</sup> / <sub>4</sub>

Housings are ductile iron.

\* For expansion bearings, this dimension can increase by the corresponding value listed in Table 7 on page 27.

# Flange Block

## USF3B5000

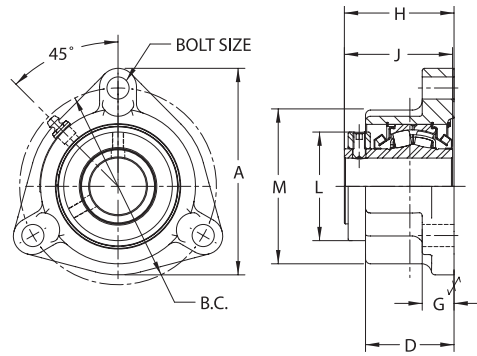

### Three Bolt Base, Collar Mount

Nomenclature	Shaft Diameter (INCHES)	A	B.C.	D	G	H*	J	L	M	Bolt Size
USF3B5000-102	1 1/8									
USF3B5000-103	1 3/16	5 1/4	4 1/2	2 1/4	13/16	2 25/32	2 3/4	2 49/64	3 15/16	3/8
USF3B5000-104	1 1/4									
USF3B5000-106	1 3/8									
USF3B5000-107	1 7/16	5 1/4	5	2 1/4	13/16	2 25/32	2 3/4	2 49/64	3 15/16	1/2
USF3B5000-108	1 1/2									

\* For expansion bearings, this dimension can increase by the corresponding value listed in Table 7 on page 27.

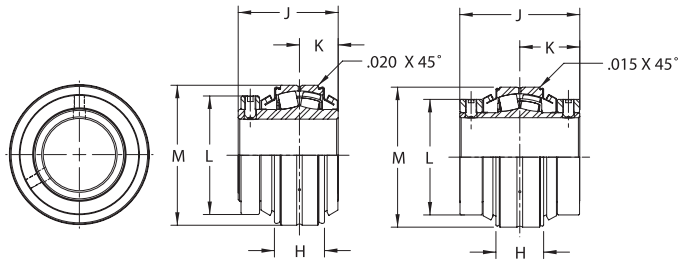

"DOUBLE COLLAR"

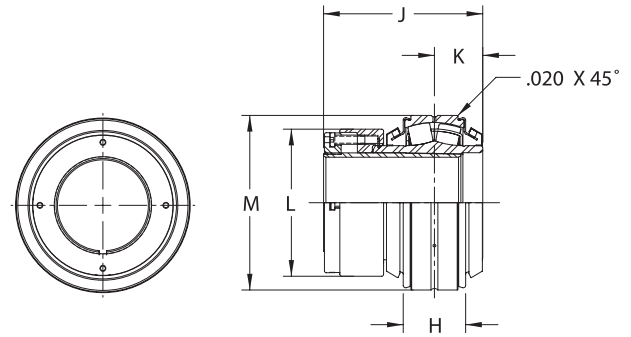

## Spherical Insert USI5000

## Spherical Insert USI5000A

Collar Mount						
Nomenclature	Bore (INCHES)	H	J	K	L	M (Nominal)
USI5000-102	1 1/8					
USI5000-103	1 3/16					
USI5000-104	1 1/4	1 15/64	2 3/4	1	2 49/64	3.1493
USI5000-106	1 3/8					
USI5000-107	1 7/16					
USI5000-108	1 1/2					
USI5000-111	1 11/16	1 7/32	2 7/8	1 3/64	2 3/4	3.3462
USI5000-112	1 3/4					
USI5000-115	1 15/16	1 17/64	2 7/8	1 1/16	3	3.5430
USI5000-200	2					
USI5000-203	2 3/16	1 23/64	3 1/8	1 9/64	3 1/4	3.9367
USI5000-207	2 7/16	1 11/16	3 3/8	1 5/16	4	4.7242
USI5000-208	2 1/2					
USI5000-211	2 11/16					
USI5000-212	2 3/4	1 23/32	3 7/8	1 25/64	4 17/32	5.1180
USI5000-215	2 15/16					
USI5000-300	3					
USI5000-303	3 3/16					
USI5000-307	3 7/16	2 1/8	4 15/32	1 45/64	5 5/16	6.2988
USI5000-308	3 1/2					
USI5000-311	3 11/16					
USI5000-315	3 15/16	2 13/32	4 15/16	1 55/64	6	7.0861
USI5000-400	4					
USI5000-407	4 7/16					
USI5000-408	4 1/2	2 11/16	6 3/4	3 3/8	6 1/2	7.8740
USI5000-415	4 15/16	3 21/64	7 27/64	3 23/32	7	9.0551
USI5000-507	5 7/16	3 21/32	9 1/32	4 33/64	8 1/2	9.8419
USI5000-515	5 15/16	4 25/64	9 25/32	4 57/64	10	11.4167
USI5000-607	6 7/16					
USI5000-608	6 1/2	4 55/64	10 1/2	5 1/4	11	12.5976
USI5000-615	6 15/16					
USI5000-700	7					

Adapter Mount						
Nomenclature	Bore (INCHES)	H	J	K	L	M (Nominal)
USI5000A-102	1 1/8					
USI5000A-103	1 3/16					
USI5000A-104	1 1/4	1 15/64	3 23/64	1	2 47/64	3.1493
USI5000A-106	1 3/8					
USI5000A-107	1 7/16					
USI5000A-108	1 1/2					
USI5000A-111	1 11/16	1 7/32	3 29/64	1 3/64	2 63/64	3.3462
USI5000A-112	1 3/4					
USI5000A-115	1 15/16	1 17/64	3 1/2	1 1/16	3 3/16	3.5430
USI5000A-200	2					
USI5000A-203	2 3/16	1 23/64	3 57/64	1 9/64	3 29/64	3.9367
USI5000A-207	2 7/16	1 11/16	4 5/16	1 5/16	3 63/64	4.7242
USI5000A-208	2 1/2					
USI5000A-211	2 11/16					
USI5000A-212	2 3/4	1 23/32	4 31/64	1 25/64	4 25/64	5.1180
USI5000A-215	2 15/16					
USI5000A-300	3					
USI5000A-303	3 3/16					
USI5000A-307	3 7/16	2 1/8	5 35/64	1 45/64	5 15/32	6.2988
USI5000A-308	3 1/2					
USI5000A-311	3 11/16					
USI5000A-315	3 15/16	2 13/32	5 15/16	1 55/64	5 13/16	7.0861
USI5000A-400	4					
USI5000A-407	4 7/16					
USI5000A-408	4 1/2	2 11/16	6 27/64	2 5/64	6 11/32	7.8740
USI5000A-415	4 15/16	3 21/64	7 1/8	2 27/64	7 13/64	9.0551
USI5000A-500	5					
USI5000A-507	5 7/16	3 21/32	7 35/64	2 39/64	7 47/64	9.8419
USI5000A-515	5 15/16	4 25/64	8 17/32	3 1/64	8 1/2	11.4167
USI5000A-607	6 7/16					
USI5000A-608	6 1/2	4 55/64	9 3/8	3 5/16	9 11/16	12.5976
USI5000A-615	6 15/16					
USI5000A-700	7					
USI5000A-708	7 1/2					
USI5000A-715	7 15/16	5 15/64	10 13/32	3 19/32	11 7/64	14.1732
USI5000A-800	8					

Note:

- 1 1/8" - 4" bore sizes have a single-lock collar.
- 4 7/16" - 7" bore sizes have double-lock collars.

## Spherical Roller Bearing Life Calculations

This section outlines the formula used to select bearing size or calculate expected bearing life for USRB™ spherical roller bearings.

### Bearing Symbols for Spherical Life Calculations

- C = Basic Dynamic Rating (lbs.) 1,000,000 rev.
- P = Equivalent Radial Load (lbs.)
- $L_{10}$  = Rated Life (hrs.)
- $F_a$  = Applied Thrust Load
- $F_r$  = Applied Radial Load
- n = Speed RPM
- X = Radial Factor
- Y = Thrust Factor
- e = Geometry Ratio

### Spherical Roller Bearing Life Calculations

$$L_{10} = \left( \frac{C}{P} \right)^{10/3} \times \frac{16,667}{n}$$

#### Shock / Vibration Factor

Table 1

Steady Loading	1.0
Light Shock / Vibration	0.5
Moderate Shock / Vibration	0.3

Multiply the theoretical life by the above factors to determine adjusted theoretical life.

## Combined Load Calculation

1. Calculate  $F_a/F_r$  and compare the value to the “e” value found in Table 2.  $F_a/F_r$  must be less than 1.
2. Choose values for “X” and “Y” from Table 2.
3. Calculate equivalent load using the following equation:  $P = XF_r + YF_a$
4. Calculate the expected  $L_{10}$  life using the life equation on page 22.
5. Determine if the calculated  $L_{10}$  meets application requirements.

6. If  $L_{10}$  is not acceptable, select another bearing size as appropriate and recalculate the  $L_{10}$  life. Continue this iterative process until an acceptable  $L_{10}$  is obtained.

NOTE: Always use (1) fixed and (1) floating spherical roller bearing.

Max. thrust for adapter mount units is C/30 lbs.

X & Y Values for Combined Loading Equation										Table 2
Shaft Diameter	Basic Dynamic Rating <b>C</b>	Basic Static Rating <b>C<sub>0</sub></b>	<b>e</b>	$F_a/F_r \leq e$		$F_a/F_r > e$		Combined Static Load Factors		
				<b>X</b>	<b>Y</b>	<b>X</b>	<b>Y</b>	<b>X<sub>0</sub></b>	<b>Y<sub>0</sub></b>	
1 1/8 - 1 1/2	20368	23609	0.34	1.0	2.0	0.67	2.9	1.0	1.9	
1 11/16 - 1 3/4	22689	28021	0.32	1.0	2.1	0.67	3.2	1.0	2.1	
1 15/16 - 2	23520	29918	0.31	1.0	2.2	0.67	3.2	1.0	2.1	
2 3/16	28087	34981	0.30	1.0	2.3	0.67	3.4	1.0	2.2	
2 7/16 - 2 1/2	44691	59535	0.31	1.0	2.2	0.67	3.3	1.0	2.2	
2 11/16 - 3	47447	65610	0.29	1.0	2.3	0.67	3.4	1.0	2.3	
3 3/16 - 3 1/2	72640	105628	0.29	1.0	2.3	0.67	3.5	1.0	2.3	
3 11/16 - 4	96050	136151	0.30	1.0	2.3	0.67	3.4	1.0	2.2	
4 7/16 - 4 1/2	111537	161283	0.30	1.0	2.3	0.67	3.4	1.0	2.2	
4 15/16 - 5	158816	247307	0.32	1.0	2.1	0.67	3.2	1.0	2.1	
5 7/16	196682	290447	0.33	1.0	2.0	0.67	3.0	1.0	2.0	
5 15/16	261346	390391	0.35	1.0	1.9	0.67	2.9	1.0	1.9	
6 7/16 - 7	334229	498544	0.35	1.0	1.9	0.67	2.9	1.0	1.9	
7 1/2 - 8	363818	587106	0.35	1.0	1.9	0.67	2.9	1.0	1.9	

Note: Regal believes that the information provided above is true and accurate; however, individual applications may vary. Thus, the information provided above cannot be relied upon as complete. The customer assumes all risk from the use thereof, and Regal assumes no responsibility for any use of the foregoing information by its customers.

## Bearing Selection Chart

This chart may be used to select Sealmaster® USRB™ unitized spherical roller bearings. Determine the operating speed and select the desired L<sub>10</sub> hours. Then select a bearing from the chart with a load rating that is greater than or equal to the actual load. Loads in this chart give the indicated L<sub>10</sub> hours and are calculated in accordance with ANSI/ABMA Standard 11 – Load Ratings and Fatigue Life for Roller Bearings. Areas designated by “-” exceed the maximum speed value. See table 4 on page 26 for maximum seal speeds.

*Bearings should operate at temperatures less than 200°F (94°C) and should not exceed 250°F (121°C) for intermittent operation. For temperatures outside of this range, consult Regal Application Engineering.*

Series	Shaft Size	Revolutions per Minute		
		L <sub>10</sub> Hours	50	100
5107	1 1/8	5000	9039	7342
	1 3/16	10000	7342	5964
	1 1/4	30000	5281	4289
	1 3/8	50000	4530	3680
	1 7/16	100000	3680	2989
	1 1/2	-	-	-
5111	-	5000	10069	8179
	1 11/16	10000	8179	6643
	1 3/4	30000	5882	4778
	-	50000	5046	4099
	-	100000	4099	3329
5115	-	5000	10438	8478
	1 15/16	10000	8478	6886
	2	30000	6098	4953
	-	50000	5231	4249
	-	100000	4249	3451
5203	-	5000	12465	10124
	-	10000	10124	8224
	2 3/16	30000	7282	5915
	-	50000	6247	5074
	-	100000	5074	4122
5207	-	5000	19833	16110
	2 7/16	10000	16110	13085
	2 1/2	30000	11586	9411
	-	50000	9940	8074
	-	100000	8074	6558
5215	2 11/16	5000	21056	17103
	2 3/4	10000	17103	13892
	2 15/16	30000	12301	9991
	3	50000	10553	8572
	-	100000	8572	6962
5307	-	5000	32237	26184
	3 3/16	10000	26184	21268
	3 7/16	30000	18832	15297
	3 1/2	50000	16157	13123
	-	100000	13123	10659
5315	-	5000	42626	34623
	3 11/16	10000	34623	28123
	3 15/16	30000	24902	20226
	4	50000	21364	17353
	-	100000	17353	14095
5407	-	5000	49499	40205
	4 7/16	10000	40205	32657
	4 1/2	30000	28917	23488
	-	50000	24808	20150
	-	100000	20150	16367
5415	-	5000	70481	57248
	4 15/16	10000	57248	46500
	5	30000	41174	33444
	-	50000	35324	28692
	-	100000	28692	23305
5507	-	5000	87285	70897
	5 7/16	10000	70897	57587
	5 1/2	30000	50991	41418
	-	50000	43746	35533
	-	100000	35533	288862
5515	-	5000	115982	94207
	-	10000	94207	76520
	5 15/16	30000	67756	55035
	-	50000	58129	47215
	-	100000	47215	38351
5615	6 7/16	5000	143889	116874
	6 1/2	10000	116874	94931
	6 15/16	30000	84059	68277
	7	50000	72115	58576
	-	100000	58576	47578
5708	-	5000	161458	131145
	7 1/2	10000	131145	106523
	7 15/16	30000	94322	76613
	8	50000	80921	65728
	-	100000	65728	53388

Table 3

	150	250	500	750	1000	1500	1750	2000	2500	3000	3500	4000
	6501	5577	4530	4011	3680	3258	3111	2989	2795	2647	2527	2428
	5281	4530	3680	3258	2989	2647	2527	2428	2271	2150	2053	1972
	3798	3258	2647	2343	2150	1903	1817	1746	1633	1546	1476	1418
	3258	2795	2271	2010	1844	1633	1559	1498	1401	1326	1266	1217
	2647	2271	1844	1633	1498	1326	1266	1217	1138	1077	1029	988
	7242	6213	5046	4468	4099	3630	3465	3329	3114	2948	2815	2704
	5882	5046	4099	3630	3329	2948	2815	2704	2529	2395	2286	2197
	4231	3630	2948	2610	2395	2120	2025	1945	1819	1722	1644	1580
	3630	3114	2529	2240	2054	1819	1737	1669	1561	1478	1411	1355
	2948	2529	2054	1819	1669	1478	1411	1355	1268	1200	1146	1101
	7507	6441	5231	4632	4249	3762	3592	3451	3228	3056	2918	2803
	6098	5231	4249	3762	3451	3056	2918	2803	2622	2482	2370	2277
	4386	3762	3056	2706	2482	2198	2099	2016	1886	1785	1705	1638
	3762	3228	2622	2322	2130	1886	1800	1730	1618	1532	1462	1405
	3056	2622	2130	1886	1730	1532	1462	1405	1314	1244	1188	1141
	8965	7691	6247	5532	5074	4493	4290	4122	3855	3650	3485	2649
	7282	6247	5074	4493	4122	3650	3485	3348	3131	2964	2830	2820
	5237	4493	3650	3232	2964	2625	2506	2408	2252	2132	2036	3113
	4493	3855	3131	2772	2543	2252	2150	2066	1932	1829	1746	3259
	3650	3131	2543	2252	2066	1829	1746	1678	1569	1486	1419	3469
	14265	12238	9940	8802	8074	7149	6826	6558	6133	5807	3841	-
	11586	9940	8074	7149	6558	5807	5545	5327	4982	4717	4088	-
	8333	7149	5807	5142	4717	4177	3988	3831	3583	3392	4513	-
	7149	6133	4982	4411	4047	3583	3421	3287	3074	2910	4725	-
	5807	4982	4047	3583	3287	2910	2779	2670	2497	2364	5029	-
	15144	12992	10553	9344	8572	7590	7247	6962	6512	6165	-	-
	12301	10553	8572	7590	6962	6165	5886	5655	5289	5008	-	-
	8847	7590	6165	5459	5008	4434	4234	4067	3804	3602	-	-
	7590	6512	5289	4683	4296	3804	3632	3489	3264	3090	-	-
	6165	5289	4296	3804	3489	3090	2950	2834	2651	2510	-	-
	23185	19891	16157	14306	13123	11620	11095	10659	9969	-	-	-
	18832	16157	13123	11620	10659	9439	9012	8658	8098	-	-	-
	13545	11620	9439	8358	7666	6788	6482	6227	5824	-	-	-
	11620	9969	8098	7170	6577	5824	5561	5342	4996	-	-	-
	9439	8098	6577	5824	5342	4730	4517	4339	4058	-	-	-
	30657	26302	21364	18917	17353	15365	14671	14095	7410	-	-	-
	24902	21364	17353	15365	14095	12480	11916	11448	7887	-	-	-
	17910	15365	12480	11051	10137	8976	8571	8234	8707	-	-	-
	15365	13182	10707	9481	8697	7701	7353	7064	9117	-	-	-
	12480	10707	8697	7701	7064	6255	5972	5738	9704	-	-	-
	35601	30542	24808	21967	20150	17843	17036	8564	-	-	-	-
	28917	24808	20150	17843	16367	14493	13838	9115	-	-	-	-
	20798	17843	14493	12833	11772	10423	9952	10063	-	-	-	-
	17843	15307	12434	11009	10099	8942	8538	10536	-	-	-	-
	14493	12434	10099	8942	8203	7264	6935	11214	-	-	-	-
	50691	43489	35324	31278	28692	25406	24258	-	-	-	-	-
	41174	35324	28692	25406	23305	20636	19703	-	-	-	-	-
	29613	25406	20636	18272	16762	14842	14171	-	-	-	-	-
	25406	21796	17704	15676	14380	12733	12158	-	-	-	-	-
	20636	17704	14380	12733	11680	10342	9875	-	-	-	-	-
	62777	53858	43746	38736	35533	31463	-	-	-	-	-	-
	50991	43746	35533	31463	28862	25556	-	-	-	-	-	-
	36674	31463	25556	22629	20758	18381	-	-	-	-	-	-
	31463	26993	21925	19414	17809	15769	-	-	-	-	-	-
	25556	21925	17809	15769	14465	12808	-	-	-	-	-	-
	83417	71565	58129	51471	47215	41808	-	-	-	-	-	-
	67756	58129	47215	41808	38351	33958	-	-	-	-	-	-
	48731	41808	33958	30069	27583	24424	-	-	-	-	-	-
	41808	35867	29133	25797	23664	20953	-	-	-	-	-	-
	33958	29133	23664	20953	19221	17019	-	-	-	-	-	-
	103488	88784	72115	63856	58576	51867	-	-	-	-	-	-
	84059	72115	58576	51867	47578	42129	-	-	-	-	-	-
	60457	51867	42129	37304	34219	30300	-	-	-	-	-	-
	51867	44498	36143	32004	29357	25995	-	-	-	-	-	-
	42129	63143	29357	25995	23846	21115	-	-	-	-	-	-
	116124	99625	80921	71653	65728	58200	-	-	-	-	-	-
	94322	80921	65728	58200	53388	47273	-	-	-	-	-	-
	67839	58200	47273	41859	38398	34000	-	-	-	-	-	-
	58200	49931	40556	35911	32942	29169	-	-	-	-	-	-
	47273	40556	32942	29169	26757	23693	-	-	-	-	-	-

## Seal Speed

This chart displays maximum speed rating for USRB™ bearing seals. Values in the table represent speeds at ideal conditions. Other application factors may reduce the speed rating of a bearing.

- Speed limits evaluated at a load of C/10.
- For speeds outside of those listed in this table, consult Regal Application Engineering.

Seal Speed		Table 4	
Shaft Size	Felt	Contact	
1 1/8 - 1 1/2	4000	3000	
1 11/16 - 1 3/4	4000	2750	
1 15/16 - 2	4000	2500	
2 3/16	3750	2200	
2 7/16 - 2 1/2	3250	1750	
2 11/16 - 3	3000	1600	
3 3/16 - 3 1/2	2500	1350	
3 11/16 - 4	2250	1200	
4 7/16 - 4 1/2	2000	1100	
4 15/16 - 5	1750	900	
5 7/16 - 5 1/2	1500	900	
5 15/16	1300	800	
6 7/16 - 7	1200	750	
7 1/2 - 8	1100	750	

## LINEAR SHAFT EXPANSION

For applications in which bearing shaft expansion is larger than the support structure expansion, this expansion must be taken into account. The change in length can be determined for steel shafts using the formula  $0.0000063 \times \text{Shaft Length (Inches)} \times \text{Temperature Change (Degrees F)}$ .

Temperature change is defined as the maximum temperature difference between the shaft and bearing support structure.

To allow for linear shaft expansion, some applications will require the bearing(s) to be of expansion type. Before installation, make certain proper linear shaft expansion is accounted for. Expansion units should be placed in a location where relative movement between the bearing insert and the housing can be tolerated. For most applications using expansion-type units, the fixed unit (non-expansion unit) is placed at the drive end of the shaft. Use Table 7 to determine if the housing unit will allow the necessary expansion. If the application requires additional expansion, consult engineering.

Note: It is recommended that applications using adapter mount units utilize one expansion unit in conjunction with one non-expansion unit. Failure to utilize one expansion and one non-expansion unit could result in reduced bearing performance.

**Notice: NOT PROVIDING EXPANSION WHERE NECESSARY MAY RESULT IN UNDESIRABLE LOADS, REDUCING THE LIFE OF THE BEARING!**

Shaft Tolerance for Collar Mount Bearings <span style="float: right;">Table 5</span>	
Nominal Shaft Diameter	Tolerances (INCHES)
1 1/8 - 2	- 0.0005
2 3/16 - 4	- 0.0010
4 7/16 - 5 15/16	- 0.0015
6 7/16 - 7	- 0.0020

Split Housing Cap Bolt Torque <span style="float: right;">Table 8</span>		
Shaft Size (INCHES)	Inch-Pounds	Foot-Pounds
5 7/16 - 6 1/2	3190	265
6 15/16 - 8	7200	600

Shaft Tolerance for Adapter Mount Bearings <span style="float: right;">Table 6</span>	
Nominal Shaft Diameter	Tolerances (INCHES)
1 1/8 - 2	- 0.003
2 3/16 - 4	- 0.004
4 7/16 - 5 15/16	- 0.005
6 7/16 - 8	- 0.006

Collar Mount Setscrew Information <span style="float: right;">Table 9</span>			
Shaft Size (INCHES)	Hex Size (INCHES)	Inch-Pounds	Foot-Pounds
1 1/8 - 1 3/4	5/32	165	14
1 15/16 - 2 1/2	3/16	295	25
2 11/16 - 3 1/2	1/4	655	55
3 11/16 - 4 1/2	5/16	1435	120
4 15/16 - 5 15/16	3/8	2150	180
6 7/16 - 7	1/2	5130	428

Housing Expansion <span style="float: right;">Table 7</span>		
Nominal Shaft Diameter	Collar Mount (INCHES)	Adapter Mount (INCHES)
1 1/8 - 1 1/2	3/16	5/32
1 11/16 - 3 1/2	1/4	7/32
3 11/16 - 4	5/16	1/4
4 7/16 - 8	3/8	9/32

Adapter Mount Cap Screw Information <span style="float: right;">Table 10</span>			
Nominal Shaft Diameter	Inch-Pounds	Hex Size (INCHES)	# Cap Screws
1 1/8 - 1 1/2	45	1/8	3
1 11/16 - 1 3/4	40	1/8	3
1 15/16 - 2	30	1/8	3
2 3/16	45	1/8	3
2 7/16 - 2 1/2	60	1/8	4
2 11/16 - 3	55	1/8	4
3 3/16 - 3 1/2	80	3/16	4
3 11/16 - 4	80	3/16	4
4 7/16 - 4 1/2	115	3/16	4
4 15/16 - 5	130	3/16	6
5 7/16 - 5 1/2	115	3/16	6
5 15/16	175	3/16	8
6 7/16 - 7	225	1/4	8
7 1/2 - 8	275	1/4	8

# LUBRICATION

Lubricant is a basic element in rolling element bearings. It is as essential to proper operation as are the races and rolling elements. Oil provides a separating layer between rolling elements and raceways and lubricates the sliding surfaces between the rolling elements and retainer. This lubrication layer eliminates or minimizes metal-to-metal contact and distributes stresses. Lubrication can also provide protection against corrosion, a barrier to contamination, and dissipation of heat.

## Lubricant

All Sealmaster® USRB™ unitized spherical roller bearings are delivered with a high-quality lithium-complex base grease with an EP additive. The bearing is ready for use with no initial lubrication required. The grease is a lithium-complex base mineral oil, NLGI Grade 2 consistency, with a base oil viscosity of ISO VG 220.

Compatibility of grease is critical; therefore, consult with Regal Application Engineering and your grease supplier to review grease compatibility. For best performance it is recommended to relubricate with lithium-complex thickened grease with a comparable NLGI consistency and base oil type and viscosity.

Lubricatable Sealmaster bearings are supplied with grease fittings or zerks for ease of lubrication with hand or automatic grease guns. Always wipe the fitting and grease nozzle clean.

**Notice: If possible, it is recommended to lubricate the bearing while rotating, until grease purge is seen from the seals. If this is not an option due to safety reasons, follow the alternate lubrication procedure below.**

Alternate Lubrication Procedure: Stop rotating equipment. Add one-half the recommended amount shown in Table 11. Start the bearing and run for a few minutes. Stop bearing and add the second half of the recommended amount. A temperature rise after lubrication, sometimes 30°F (17°C), is normal. Bearings should operate at temperatures less than 200°F (94°C) and should not exceed 250°F (121°C) for intermittent operation. For lubrication guide see Table 12.

*Note: The tables below state general lubrication guides and are intended as suggested or starting points only. For best results, specific applications should be monitored regularly and lubrication intervals and amounts adjusted accordingly.*

Grease Charge		Table 11
Shaft Size (INCHES)	Grease Charge (OUNCES)	
1 1/8 - 1 1/2	0.2	
1 11/16 - 1 3/4	0.2	
1 15/16 - 2	0.25	
2 3/16	0.4	
2 7/16 - 2 1/2	0.6	
2 11/16 - 3	0.75	
3 3/16 - 3 1/2	1.2	
3 11/16 - 4	2	
4 7/16 - 4 1/2	2.75	
4 15/16 - 5	6.1	
5 7/16 - 5 1/2	6.1	
5 15/16	10.6	
6 7/16 - 7	13.9	
7 1/2 - 8	17.6	

Relubrication Recommendations				Table 12
Environment	Temperature (°F)	Speed (% CATALOG MAX)	Frequency	
Dirty	-20 to 250	0 - 100 %	Daily to 1 week	
		0 - 25% 26 - 50% 51 - 75% 76 - 100%	4 to 10 months 1 to 4 months 1 week to 1 month Daily to 1 week	
Clean	125 to 175	0 - 25% 26 - 50% 51 - 75% 76 - 100%	2 to 6 weeks 1 week to 1 month Daily to 1 week Daily to 1 week	
		175 to 250	0 - 100 %	Daily to 1 week

Note: See table 4 on page 26 for maximum seal speeds. Refer to back cover for relevant disclaimer.

## USRB™ Bearing Vibration Analysis

The following equations are used to calculate the fundamental frequencies for Sealmaster® USRB™ unitized spherical roller bearings.

1. All information can be linked to three factors:

- Shaft size
- Unit number

For USRB5000-207-C, the shaft size is 2 7/16".

- Insert number

For USI5000-207-C the shaft size is 2 7/16".

2. Use the information obtained from Step 1 to select the vibration geometry information (R, I, O and F) from Table 13.

3. Use this information to calculate the fundamental bearing frequencies:

- Roller Spin Frequency (Hz) = R x RPM
- Inner Roller Pass Frequency (Hz) = I x RPM
- Outer Roller Pass Frequency (Hz) = O x RPM
- Fundamental Train Frequency (Hz) = F x RPM

## Bearing Symbols for Vibration Analysis

RPM – Shaft Speed (Revolutions per Minute)

R – Roller Spin Frequency Factor

I – Inner Roller Pass Frequency Factor

O – Outer Roller Pass Frequency Factor

F – Fundamental Train Frequency Factor

**Vibration Geometry Information**

**Table 13**

Shaft Size (INCHES)	Factor for Roller Spin	Factor for Inner Roller Pass	Factor for Outer Roller Pass	Factor for F.T.F.
	R	I	O	F
1 1/8 - 1 1/2	0.0977	0.1549	0.1117	0.0070
1 11/16 - 1 3/4	0.1077	0.1722	0.1278	0.0071
1 15/16 - 2	0.1151	0.1804	0.1363	0.0072
2 3/16	0.1106	0.1717	0.1283	0.0071
2 7/16 - 2 1/2	0.1105	0.1812	0.1354	0.0071
2 11/16 - 3	0.1204	0.1983	0.1517	0.0072
3 3/16 - 3 1/2	0.1205	0.1889	0.1444	0.0072
3 11/16 - 4	0.1088	0.1816	0.1351	0.0071
4 7/16 - 4 1/2	0.1138	0.1806	0.1360	0.0072
4 15/16 - 5	0.1171	0.1894	0.1439	0.0072
5 7/16 - 5 1/2	0.1037	0.1730	0.1270	0.0071
5 15/16	0.1009	0.1735	0.1265	0.0070
6 7/16 - 7	0.1020	0.1733	0.1267	0.0070
7 1/2 - 8	0.1115	0.1809	0.1357	0.0071

## MOUNTING COLLAR MOUNT UNITS

### 1. INSPECT SHAFT and BORE

- Shaft should be within tolerance range shown in Table 5, page 27, clean and free of nicks and burrs.
- Mount bearings on unused section of shafting or repair/replace as required.
- Inspect shaft and bearing bore for debris or contaminants. Wipe clean as necessary.

### 2. CHECK SUPPORT SURFACES

- Make sure housing base and support surfaces are clean and free from nicks and burrs.
- If the housing elevation is adjusted with shims, these must cover the entire contact area between the housing and the support surface.

### 3. INSTALL UNIT

- Keep weight off bearing during mounting.
- Slide unit onto shaft by pushing on inner ring.
- If difficult to install, use a piece of emery cloth to reduce high spots on shaft.
- Do not hammer on any component of the bearing and/or the shaft.
- Split housings have the provision for a lifting lug. If used, this provision is only intended to support the weight of the housed bearing assembly.

### 4. FASTEN UNIT IN PLACE

- Install mounting bolts and check bearing alignment; align units as closely as possible.
- These bearings are designed for maximum permissible misalignment of  $\pm 2^\circ$ . Installation, handling or operation of the bearing in excess of the maximum permissible misalignment of  $\pm 2^\circ$  can cause reduction in bearing performance, resulting in equipment failure and/or personal injury.
- Once alignment is within the allowable range, tighten mounting bolts to recommended fastener torque.
- Check shaft for freedom of rotation by rotating shaft by hand in both directions.

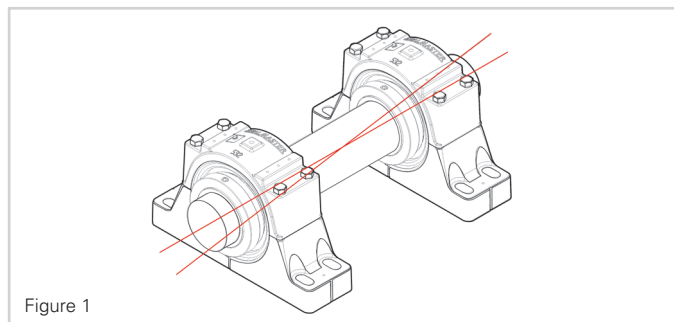

Figure 1

### 5. POSITION INSERT

- If expansion unit is used, it must be located in the housing to allow axial shaft expansion and/or contraction.
- Position bearing insert to maximize the axial expansion in the desired direction.
- It may be necessary to unload the bearing while positioning the bearing insert.

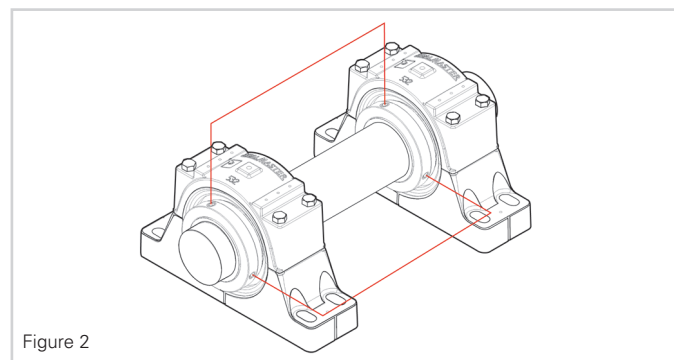

Figure 2

### 6. TIGHTEN SETSCREWS

- Setscrews in multiple bearing applications should be aligned as seen in Figure 2 above. Setscrews that are not properly aligned can induce shaft misalignment between two bearings.
- Step 1: Torque first setscrew to  $\frac{1}{2}$  recommended torque (Table 9, page 27).
- Step 2: Torque second setscrew to full recommended torque (Table 9, page 27).
- Step 3: Torque first setscrew to full recommended torque (Table 9, page 27).
- Double-lock collar mount units: Repeat steps 1 to 3 on second lock collar.
- Rotate shaft by hand to make sure it turns smoothly.

## MOUNTING ADAPTER MOUNT UNITS

### 1. INSPECT SHAFT AND BORE

- Shaft should be within tolerance range shown in Table 6, page 27, clean and free of nicks and burrs.
- Mount bearings on unused section of shafting or repair/replace as required.
- Inspect shaft and bearing bore for debris or contaminants. Wipe clean as necessary.

**Caution: Do not apply grease, oil or anti-seize compound to the tapered surfaces, bore and shafting. If any of these substances are applied, equipment failure and personal injury could result.**

### 2. CHECK SUPPORT SURFACES

- Make sure housing base and support surfaces are clean and free from nicks and burrs.
- If the housing elevation is adjusted with shims, these must cover the entire contact area between the housing and the support surface.

### 3. INSTALL UNIT

- It is recommended that applications using adapter mount units utilize one expansion unit in conjunction with one non-expansion unit.
- Failure to utilize one expansion and one non-expansion unit could result in reduced bearing performance.
- Keep weight off bearing during mounting.
- Slide unit onto shaft by pushing on inner ring.
- If difficult to install, use a piece of emery cloth to reduce high spots on shaft.
- Do not hammer on any component of the bearing and/or the shaft.
- Split housings have the provision for a lifting lug. If used, this provision is only intended to support the weight of the housed bearing assembly.

### 4. FASTEN UNIT IN PLACE

- Install mounting bolts and check bearing alignment; align bearing units as closely as possible.
- These bearings are designed for maximum permissible misalignment of  $\pm 2^\circ$ . Installation, handling or operation of the bearing in excess of the maximum permissible misalignment of  $\pm 2^\circ$  can cause reduction in bearing performance, resulting in equipment failure and/or personal injury.
- Once alignment is within the allowable range, tighten mounting bolts to recommended fastener torque.
- Check shaft for freedom of rotation by rotating shaft by hand in both directions.

### 5. POSITION INSERT

- If an expansion unit is used, the bearing must be located in the housing.
- If the direction of shaft growth is in the direction seen in Figure 3, align the bearing as shown.
- If the direction of shaft growth is opposite to that shown in Figure 3, center the insert in the housing.

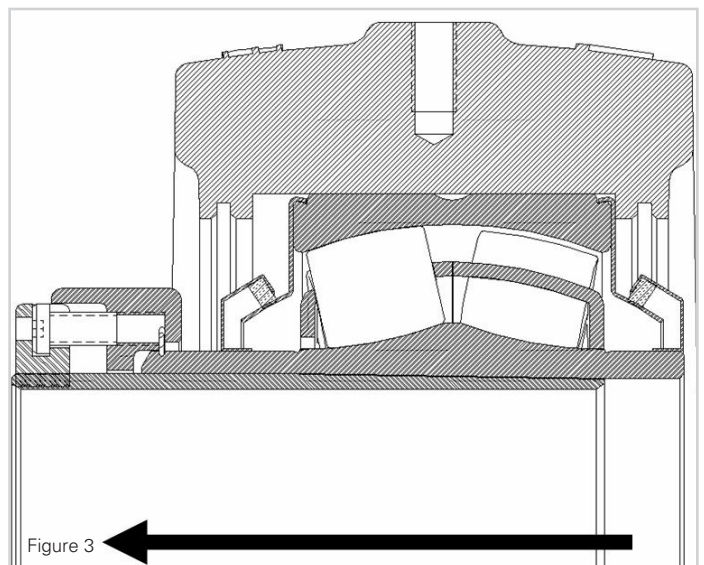

## **MOUNTING ADAPTER MOUNT UNITS (cont'd.)**

### **6. SHAFT LOCK**

- Step 1: Tighten cap screws in specified order as seen in Figure 4; continue tightening until all cap screws have become snug.
- Step 2: Using a torque wrench, tighten each screw to  $\frac{1}{2}$  the appropriate torque value (Table 10, page 27).
- Step 3: In the same order, repeat the procedure. tightening each screw to the full appropriate torque value (Table 10, page 27).
- Step 4: Follow the same pattern and verify that each cap screw has met the appropriate torque value and all cap screws have achieved equivalent resistance.
- Step 5: Continue to tighten all other bearings in the same fashion, continuously checking for freedom of rotation.

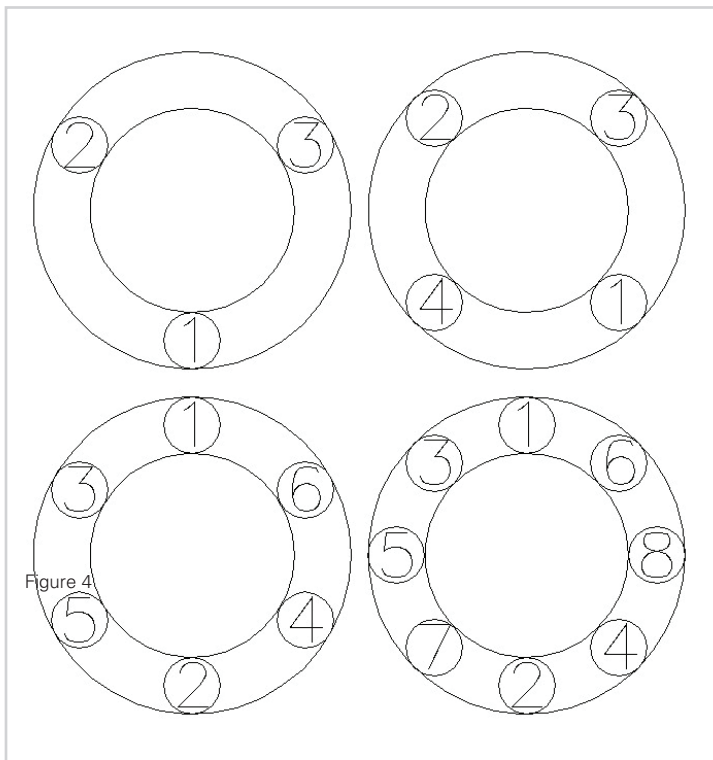

## **REPLACING EXISTING SEALMASTER® INSERTS**

### **REMOVAL:**

#### **1. REMOVE HOUSING**

- **TWO-PIECE HOUSINGS**

- Remove cap bolts.
- Remove top half of housing.

- **ONE-PIECE HOUSINGS**

- Remove snap ring and spacer ring from housing bore.
- Do not lose snap ring or spacer ring.

#### **2. REMOVE BEARING FROM SHAFT**

- Setscrew units: Loosen setscrews and slide bearing off shaft.
- Adapter mount units: Loosen cap screws in the specified order as seen in Figure 4 and slide the bearing off the shaft.
- **DO NOT HAMMER ON ANY COMPONENT OF THE BEARING AND/OR SHAFT.**

#### **2. SECURE IN HOUSING**

- Be sure to check the bearing for proper alignment; align bearing units as closely as possible.
- These bearings are designed for maximum permissible misalignment of +/- 2°. Installation, handling or operation of the bearing in excess of the maximum permissible misalignment of +/- 2° can cause reduction in bearing performance, resulting in equipment failure and/or personal injury.

- **TWO-PIECE HOUSINGS**

- Install top half of the housing; ensure alignment between location pin and location hole.
- Tighten down the cap bolts to the recommended torque in Table 8, page 27.

- **ONE-PIECE HOUSINGS**

- Replace spacer ring into bearing housing.
- Replace snap ring into snap-ring groove in bearing housing.

### **REPLACEMENT:**

#### **1. LOAD NEW INSERT**

- Shaft should be within applicable tolerance range shown in Table 5 or 6, page 27, clean and free of nicks and burrs.
- Mount bearings on unused section of shafting or repair/replace as required.
- Inspect shaft, bearing bore, housing bore and spacer ring for debris or contaminants. Wipe clean as necessary.

#### **3. REFER TO STEPS 5 AND 6 FROM PREVIOUS INSTALLATION SECTIONS FOR THE RESPECTIVE SHAFT LOCKING MECHANISM.**

**Refer to back cover for relevant disclaimer.**

***Caution: Do not apply grease, oil or anti-seize compound to the tapered surfaces, bore and shafting. If any of these substances are applied, equipment failure and personal injury could result.***

# SEALMASTER®

## Regal Beloit America, Inc.

7120 New Buffington Road  
Florence, KY 41042

Customer Service: 800-626-2120

Fax: 800-262-3292

Technical Service: 800-626-2093

[www.RegalBeloit.com](http://www.RegalBeloit.com)

### APPLICATION CONSIDERATIONS

The proper selection and application of power transmission products and components, including the related area of product safety, is the responsibility of the customer. Operating and performance requirements and potential associated issues will vary appreciably depending upon the use and application of such products and components. The scope of the technical and application information included in this publication is necessarily limited. Unusual operating environments and conditions, lubrication requirements, loading supports, and other factors can materially affect the application and operating results of the products and components and the customer should carefully review its requirements. Any technical advice or review furnished by Regal Beloit America, Inc. and/or its affiliates ("Regal") with respect to the use of products and components is given in good faith and without charge, and Regal assumes no obligation or liability for the advice given, or results obtained, all such advice and review being given and accepted at customer's risk.

For a copy of our Standard Terms and Conditions of Sale, please visit <http://www.regalbeloit.com> (please see link at bottom of page to "Standard Terms and Conditions of Sale"). These terms and conditions of sale, disclaimers and limitations of liability apply to any person who may buy, acquire or use a Regal product referred to herein, including any person who buys from a licensed distributor of these branded products.

Regal, SealMaster and USRB are trademarks of Regal Beloit Corporation or one of its affiliated companies.

©2016, 2018 Regal Beloit Corporation, All Rights Reserved. MCC18011E • Form# 9200E

The REGAL logo consists of the word "REGAL" in a bold, white, sans-serif font, set against a dark grey, trapezoidal background that tapers to the right. A registered trademark symbol (®) is located to the upper right of the logo.

**REGAL**®