

TIMKEN

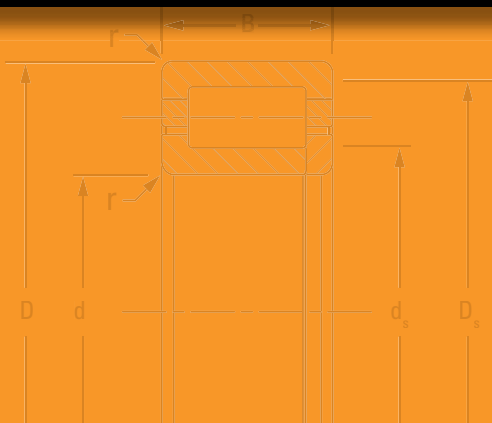

TIMKEN CYLINDRICAL ROLLER BEARING CATALOG



CYLINDRICAL ROLLER BEARING CATALOG INDEX

TIMKEN OVERVIEW.....	2
SHELF LIFE POLICY	6
CYLINDRICAL ROLLER BEARING INTRODUCTION	8
ENGINEERING	
Bearing Types and Cages.....	10
Metric System Tolerances.....	13
Mounting, Fitting, Setting and Installation Practices	16
Shaft and Housing Fits	22
Operating Temperatures.....	40
Heat Generation and Dissipation	43
Torque	44
Lubrication	45
CYLINDRICAL ROLLER BEARINGS	
Introduction.....	55
Nomenclature.....	56
One-Row Metric ISO Series.....	58
One-Row Standard Series	72
Full-Complement (NCF).....	74
Two-Row	76
Four-Row.....	82
HJ Series.....	96
Inner Rings (IR).....	100
5200, A5200 Metric Series	102



TIMKEN. WHERE YOU TURN.

Turn to Timken to move ahead of the competition and stand out as a leader in your industry.

When you turn to us, you receive more than high-quality products and services; you acquire a worldwide team of highly trained and experienced associates, eager to help you keep production rates high and downtime low.

Whether it is a wheel assembly for a family vehicle, bearings outfitted for a deep-sea oil drilling rig, repair services for rail bearings or steel for an aircraft engine shaft, we supply the products and services you need that help keep the world turning.



FRICITION MANAGEMENT SOLUTIONS – A TOTAL SYSTEMS APPROACH

Your industry is ever-changing, from the evolution of advanced motion-control systems to the demands from your customers. Turn to us to stay ahead of the curve.

We use our friction-management know-how to offer solutions that maximize performance, fuel-efficiency and equipment life. We also offer integrated services that extend well beyond bearings, including condition monitoring systems and services, encoders and sensors, seals, premium lubricants and lubricators.

Timken's wide range of friction management solutions can include evaluations of your entire system – not just individual components. This provides cost-effective solutions to help you reach specific application goals. Working together, we help you meet these demands and ensure all your systems run smoothly.



TECHNOLOGY THAT MOVES YOU

Innovation is one of our core values, and we're known for our ability to solve engineering challenges.

We focus on improving performance in the most difficult applications, and we're passionate about creating technical solutions and services that help your equipment perform faster, harder, smoother and more efficiently.

To do this, we invest in:

- **People**, attracting and hiring scholars, engineers and specialists from across the globe who are experts in mechanical power transmission, antifriction bearing design, tribology, metallurgy, clean steel production, precision manufacturing, metrology and engineered surfaces and coatings.
- **Tools**, including state-of-the-art laboratories, computers and manufacturing equipment.
- **The Future**, identifying new concepts that make you a standout in your industry for years to come. Our ongoing investment in research and development activities allows us to grow our capabilities, expand our product and service portfolio, and deliver value over the long term.

We're committed to finding new avenues for system sustainability. In the area of power density, we're creating systems where we replace larger, more cumbersome components with smaller, more efficient bearings to help improve systems' performance.

Wherever you're located, you can count on us at technology centers in North America, Europe and Asia - as well as in our manufacturing facilities and field offices on six continents - to develop ideas and resources to transform your concepts into reality.





A BRAND YOU CAN TRUST

The Timken brand stands for quality, innovation and dependability.

We take pride in the quality of our work, and you gain the peace-of-mind of knowing that each box contains an industry-trusted product. As our founder, Henry Timken, said, "Don't set your name to anything you will ever have cause to be ashamed of."

We continue this mindset through the Timken Quality Management System (TQMS). With TQMS, we promote continuous quality improvements in our products and services to our global operations and supply chain networks. It helps us ensure that we're consistently applying quality management practices throughout the company. We also register each of our production facilities and distribution centers to the appropriate quality system standards for the industries they serve.

ABOUT THE TIMKEN COMPANY

The Timken Company keeps the world turning with innovative friction management and power transmission products and services that are critical to help hard-working machinery to perform efficiently and reliably. With sales of \$4.1 billion in 2010, and operations in 30 countries with approximately 20,000 people, Timken is Where You Turn[®] for better performance.

ABOUT THIS CATALOG

Timken offers an extensive range of bearings and accessories in both imperial and metric sizes. For your convenience, size ranges are indicated in millimeters and inches. Contact your Timken sales representative to learn more about our complete line for the special needs of your application.

USING THIS CATALOG

We are committed to providing our customers with maximum service and quality. This publication contains dimensions, tolerances and load ratings as well as an engineering section describing fitting practices for shafts and housings, internal clearances, materials and other bearing features. It can provide valuable assistance in the initial consideration of the type and characteristics of the bearing that may best suit your particular needs.

Every reasonable effort has been made to ensure the accuracy of the information contained in this writing, but no liability is accepted for errors, omissions or for any other reason.

Timken products are sold subject to Timken's terms and conditions of sale, including its limited warranty and remedy. Please contact your Timken sales representative with questions.

CATALOG FEATURES

Dimensional and load rating data, within the various types and styles of bearings, is organized by size.

ISO and ANSI/ABMA, as used in this publication, refer to the International Organization for Standardization and the American National Standards Institute/American Bearing Manufacturers Association.



NOTE

Product performance is affected by many factors beyond the control of Timken. Therefore, the suitability and feasibility of all designs and product selections should be validated by you. This catalog is provided solely to give you, a customer of Timken or its parent or affiliates, analysis tools and data to assist you in your design. No warranty, expressed or implied, including any warranty of fitness for a particular purpose, is made by Timken. Timken products and services are sold subject to a Limited Warranty.

You can see your Timken representative for more information.

SHELF LIFE AND STORAGE OF GREASE-LUBRICATED BEARINGS AND COMPONENTS

Timken guidelines for the shelf life of grease-lubricated rolling bearings, components and assemblies are set forth below. Shelf life information is based on test data and experience. Shelf life should be distinguished from lubricated bearing/component design life as follows:

SHELF LIFE POLICY

Shelf life of the grease-lubricated bearing/component represents the period of time prior to use or installation. The shelf life is a portion of the anticipated aggregate design life. It is impossible to accurately predict design life due to variations in lubricant bleed rates, oil migration, operating conditions, installation conditions, temperature, humidity and extended storage.

Shelf life values, available from Timken, represent a maximum limit – and assume adherence to the Timken suggested storage and handling guidelines. Deviations from Timken's storage and handling guidelines may reduce shelf life. Any specification or operating practice that defines a shorter shelf life should be used. Timken cannot anticipate the performance of the grease lubricant after the bearing or component is installed or placed in service.

TIMKEN IS NOT RESPONSIBLE FOR THE SHELF LIFE OF ANY BEARING/COMPONENT LUBRICATED BY ANOTHER PARTY.

STORAGE

Timken suggests the following storage guidelines for its finished products (bearings, components and assemblies, hereinafter referred to as "Products"):

- Unless directed otherwise by Timken, Products should be kept in their original packaging until they are ready to be placed into service.
- Do not remove or alter any labels or stencil markings on the packaging.
- Products should be stored in such a way that the packaging is not pierced, crushed or otherwise damaged.
- After a Product is removed from its packaging, it should be placed into service as soon as possible.
- When removing a Product that is not individually packaged from a bulk pack container, the container should be resealed immediately after the Product is removed.
- Do not use Product that has exceeded its shelf life as defined in Timken's shelf life guidelines statement.
- The storage area temperature should be maintained between 0° C (32° F) and 40° C (104° F); temperature fluctuations should be minimized.
- The relative humidity should be maintained below 60 percent and the surfaces should be dry.
- The storage area should be kept free from airborne contaminants such as, but not limited to, dust, dirt, harmful vapors, etc.
- The storage area should be isolated from undue vibration.
- Extreme conditions of any kind should be avoided.

Inasmuch as Timken is not familiar with a customer's particular storage conditions, these guidelines are strongly suggested. However, the customer may very well be required by circumstance or applicable government requirements to adhere to stricter storage requirements.

Most bearing types are typically shipped protected with a corrosion-preventive compound that is not a lubricant. Such bearings may be used in oil-lubricated applications without removal of the corrosion-preventive compound. When using some specialized grease lubrications, it is advisable to remove the corrosion-preventive compound before packing the bearings with suitable grease.

Some bearing types in this catalog are prepacked with general purpose grease suitable for their normal application. Frequent replenishment of the grease may be necessary for optimum performance. Care must be exercised in lubricant selection, however, since different lubricants are often incompatible.

When specified by the customer, other bearings may be ordered pre-lubricated.

Upon receipt of a bearing shipment, ensure that the bearings are not removed from their packaging until they are ready for mounting so that they do not become corroded or contaminated. Bearings should be stored in an appropriate atmosphere in order that they remain protected for the intended period.

Any questions concerning shelf life or storage should be directed to your local sales office.



⚠ WARNING

Failure to observe the following warnings could create a risk of death or serious injury.

Proper maintenance and handling practices are critical.
Always follow installation instructions and maintain proper lubrication.

Never spin a bearing with compressed air.
The rollers may be forcefully expelled.

TIMKEN® CYLINDRICAL ROLLER BEARINGS - Offering Selection and Superior Performance

Your success depends on the performance of your equipment, especially when it faces harsh environments and high radial loads. To keep your uptime high and downtime low, turn to Timken® cylindrical roller bearings.

INDUSTRY PRESENCE

Timken cylindrical roller bearings effectively reduce friction and help transmit power in applications like:

- Power generation
- Oil fields
- Crop shears
- Gear drives
- Hoists
- Metals construction
- Mining
- Aggregate processing
- Pumps
- Rolling mills
- Wheel-end planetaries
- Wind energy
- Other industrial equipment

THE TIMKEN DIFFERENCE

Cooler operating temperatures. High durability. Longer-lasting performance. A wide range of sizes. Our brand stands for high quality, reliability and outstanding performance. Your applications may run better, produce more and experience improved uptime when equipped with Timken cylindrical roller bearings. As a result, you see a reduction in overall operating costs.

Each bearing is backed by a skilled team of global experts, providing you with the industry's best design, application knowledge and 24/7 field-engineering support.

DESIGN FEATURES

Featuring premium cages, unique internal geometries, enhanced surface textures and compact designs, these bearings meet or exceed expectations for longer bearing life.

A radial cylindrical roller bearing consists of an inner and/or outer ring and a complement of controlled-contour cylindrical rollers. Depending on the style of bearing, either the inner or the outer ring will have two roller-guiding ribs. The other ring, separable from the assembly, has one rib or none. The ring with two ribs axially locates the position of the roller assembly. The diameters of these ribs may be used to support the roller. One of the ribs may carry light thrust loads when an opposing rib is provided in the mating ring.

ENSURING QUALITY

The quality of our materials is just as important as our designs in helping machines run more efficiently. We're the only bearing manufacturer in the world that makes our own steel. By using clean, high-alloy steel in our cylindrical roller bearings, we can ensure the overall quality of our product.

We also implement our Worldwide Quality Standards in every manufacturing facility so that each bearing meets the same performance standards wherever in the world it's manufactured.

PRODUCT OFFERING

You can select product from a complete line of high-performance cylindrical roller bearings. Our product line includes full-complement, one-, two- and four-row designs, all developed to meet your application requirements. Sizes range from 60 mm (2.5591 in.) to 2000 mm (78.7402 in.).

Updates are made periodically to this catalog. Visit www.timken.com for the most recent version of the Cylindrical Roller Bearing Catalog.

TABLE 1. RADIAL CYLINDRICAL ROLLER BEARING TYPES AND SIZES

Bearing Type	Available Size Range
Single-row	60 - 2000 mm (2.3622 - 78.7402 in.)
Full-complement (NCF)	100 - 2000 mm (3.9370 - 78.7402 in.)
Two-row	80 - 2000 mm (3.1496 - 78.7402 in.)
Four-row	140 - 2000 mm (4.7244 - 78.7402 in.)

ENGINEERING

The following topics are covered within this engineering section:

- Cylindrical roller bearing design types.
- Cage design types.
- Fitting practice and mounting recommendations.
- Lubrication recommendations.

This engineering section is not intended to be comprehensive, but does serve as a useful guide in cylindrical roller bearing selection.

To view the complete engineering catalog, please visit www.timken.com. To order the catalog, please contact your Timken engineer and request a copy of the Timken Engineering Manual, order number 10424.

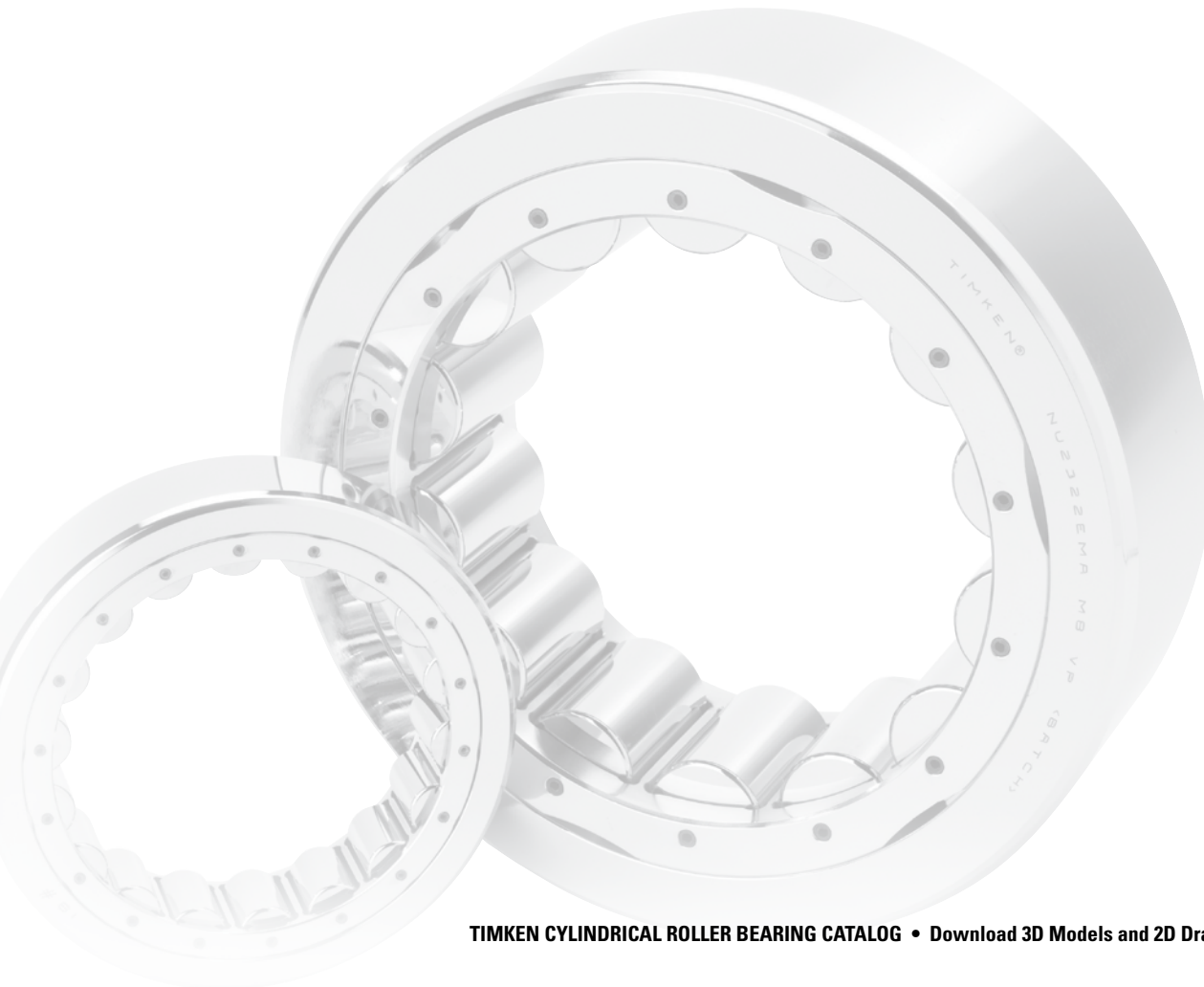
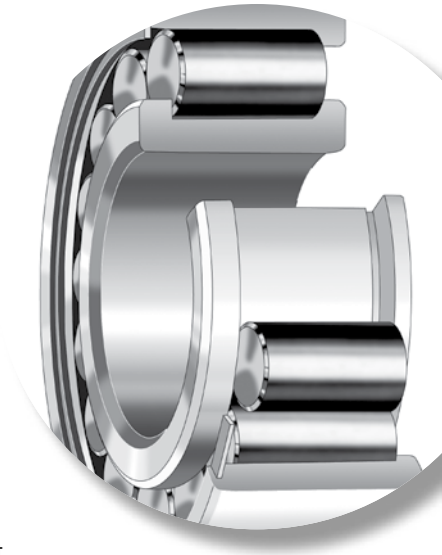

RADIAL CYLINDRICAL ROLLER BEARING TYPES AND CAGES

Radial cylindrical roller bearings can offer higher radial load capacity than other bearing designs. The Timken Company offers a wide range of full complement, one -, two -, and four-row designs to meet various application requirements.

RADIAL CYLINDRICAL ROLLER BEARINGS

STANDARD STYLES

Timken® cylindrical roller bearings consist of an inner and outer ring, a roller-retaining cage, and a complement of controlled-contour cylindrical rollers. Depending on the type of bearing, either the inner or the outer ring has two roller-guiding ribs. The other ring is separable from the assembly and has one rib or none. The ring with two ribs axially locates the position of the roller assembly. The ground diameters of these ribs may be used to support the roller cage. One of the ribs may be used to carry light thrust loads when an opposing rib is provided.

The decision as to which ring should be double ribbed is normally determined by considering assembly and mounting procedures in the application.

Type NU has double-ribbed outer and straight inner rings. Type N has double-ribbed inner and straight outer rings. The use of either type at one position on a shaft is ideal for accommodating shaft expansion or contraction. The relative axial displacement of one ring to the other occurs with minimum friction while the bearing is rotating. These bearings may be used in two positions for shaft support if other means of axial location are provided.

Type NJ has double-ribbed outer and single-ribbed inner rings. Type NF has double-ribbed inner and single-ribbed outer rings. Both types can support heavy radial loads, as well as light unidirectional thrust loads. The thrust load is transmitted between the diagonally opposed rib faces in a sliding action. When limiting thrust conditions are approached, lubrication can become critical. Your Timken engineer should be consulted for assistance in such applications. When thrust loads are very light, these bearings may be used in an opposed mounting to locate the shaft. In such cases, shaft endplay should be adjusted at time of assembly.

Type NUP has double-ribbed outer and single-ribbed inner ring with a loose rib that allows the bearing to provide axial location

in both directions. Type NP has a double-ribbed inner ring and a single-ribbed outer ring with a loose rib. Both types can carry heavy radial loads and light thrust loads in both directions. Factors governing the thrust capacity are the same as for types NJ and NF bearings.

A type NUP or NP bearing may be used in conjunction with type N or NU bearings for applications where axial shaft expansion is anticipated. In such cases, the N or NU bearing accommodates the shaft expansion. The NUP or NP bearing is considered the fixed bearing because the ribs restrict the axial movement of the rolling element. The fixed bearing is usually placed nearest the drive end of the shaft to minimize alignment variations in the drive. Shaft endplay, or float, is determined by the axial clearance in the fixed bearing.

Types NU, N, NJ, NF, NUP and NP conform to ISO and DIN standards for loose rib rings (thrust collars) and typical industry diameters over or under roller.

The cylindrical roller bearing part numbers are in accordance with ISO 15. They are composed of four digits, the first two digits identify the dimensional series and the last two digits of the part number are the bore size divided by 5. In the dimensional series, the first digit is the width series and the second is the diameter (outer) series. The width series increase width in the sequence 8 0 1 2 3 4 5 6 7. The diameter series increase radial section in the sequence 7 8 9 0 1 2 3 4.

Types having an R prefix are similar in construction to their N counterparts. However, they were designed to conform to ABMA standards.

Inch-size bearings are identified by the letter I in the part number. RIU, for example, indicates an inch bearing while RU indicates the equivalent style in metric dimensions.

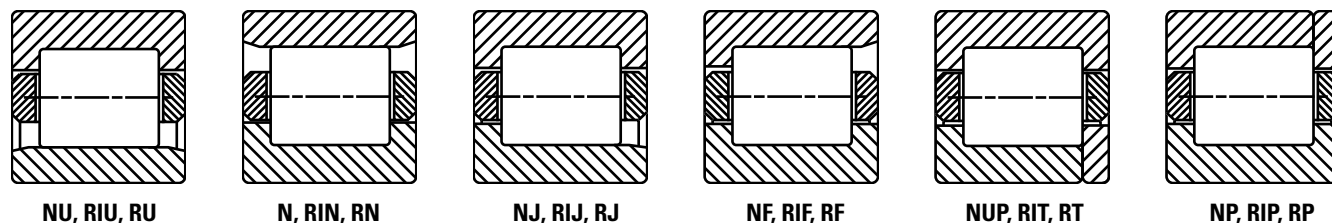

Fig. 1. Radial cylindrical roller bearings.

EMA SERIES

The Timken® single-row EMA series cylindrical roller bearings incorporate a unique cage design, proprietary internal geometry and special surface textures. These features help to improve bearing performance and can help to improve uptime and reduce maintenance costs.

The cage is a one-piece brass design with full-milled pockets. It is a land-riding cage which, unlike traditional roller-riding cages, minimizes drag on the roller elements. This reduces heat generation and improves bearing life. The high cage rigidity allows for more rollers than possible with other brass cage configurations.

Proprietary profiles on the rings and/or rollers increase the ability to handle heavier loads than competing designs.

Engineered processes for rings and rollers provide enhanced surface textures, resulting in lower friction, lower operating temperatures and longer bearing life.

EMA series bearings are available in types N, NU, NJ and NUP.

FULL-COMPLEMENT (NCF)

The full-complement (NCF) single-row bearings include integral flanges on the inner and outer rings. These bearings also can manage axial loads in one direction and permit small axial displacements.

5200 METRIC SERIES

This series features enhanced radial load ratings due to its internal design proportions. In this series, the outer ring is double-ribbed and the inner ring is full-width with a cylindrical O.D. The bearing also can be furnished without an inner ring for applications where radial space is limited. When so used, the shaft journal must be hardened to HRC 58 minimum, and the

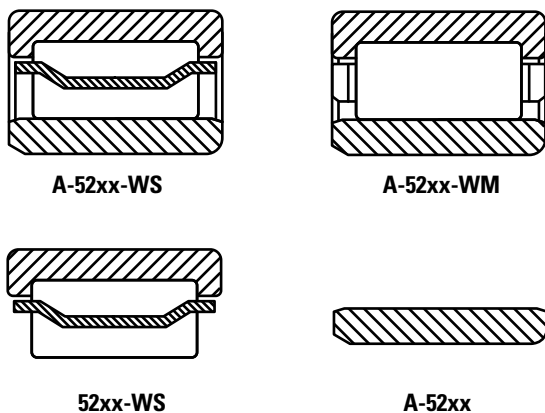

Fig. 2. 5200 metric series bearings.

surface finished to 15 RMS maximum. The W designation in the suffix indicates the outer ring is provided. The inner ring also can be furnished separately. The A prefix indicates that the inner ring is furnished either separately or as part of the assembly.

The bearing is usually provided with a rugged stamped-steel cage (S designation) and is land-riding on the outer ring ribs. The cage features depressed bars, which not only space rollers evenly, but retain them as a complete assembly with the outer ring. Cages of machined brass (M designation) are available for applications where reversing loads or high speeds might indicate their need. Outer rings are made from bearing quality alloy steel. The inner rings are deep-case hardened to accommodate the hoop stresses resulting from heavy press fits.

The standard bearing is produced with radial internal clearances designated as R6. Other internal clearances can be supplied upon request. Proper roller guidance is assured by integral ribs and roller end clearance control.

TWO-ROW BEARINGS

Two-row, or double-row, cylindrical bearings offer added radial capacity over tradition one-row types. These bearing types are interchangeable so the dimensions and diameter under the rollers (NNU style) and diameter over the rollers (NN style) are held to an ISO/DIN standard. The standard cage design is a drilled pocket, finger-style retainer.

FOUR-ROW BEARINGS

Four-row cylindrical bearings have an extremely high radial load capacity, but no thrust capacity. This bearing type is mostly used in roll neck and work roll applications in the metal rolling industry. Straight and tapered bore designs are available.

CYLINDRICAL ROLLER BEARING CAGES

STAMPED-STEEL CAGES

Stamped-steel cages for cylindrical roller bearings consist of low-carbon steel and are manufactured using a series of cutting, forming, and punching operations. These cages are made in a variety of different designs and are suitable for most general purpose cylindrical roller bearing applications. One specific type is the S-type design for the 5200 series cylindrical roller bearing, which is a land-riding cage piloted on the outer ring ribs. This design has depressed cage bridges which evenly space the rolling elements and retain them on the outer ring. Stamped-steel cages are easily mass produced and can be used in high-temperature and harsh-lubricant environments.

Fig. 3. S-type cage.



MACHINED CAGES

Machined cages are an option for smaller cylindrical bearing sizes, and are typically made from brass. Machined cage designs for cylindrical roller bearings offer increased strength for more demanding applications.

Designs can be one-piece or two-piece cages. One-piece designs can be either a finger-type as shown in fig. 4 or a standard cage configuration having fully milled pockets. The one-piece finger-type and the two-piece design with cage ring (fig. 5) are more common in standard cylindrical roller bearings. They also are roller-guided designs.

The one-piece version with fully milled roller pockets (fig. 6) is our premium cage. This cage is used with our EMA series bearings. Unlike traditional roller-riding cages, it is a land-riding cage which minimizes drag on the roller elements. This reduces heat generation, resulting in improved bearing life. Compared to a two-piece design, this one-piece cage also reduces heat and wear by enhancing lubrication flow.

PIN-TYPE CAGES

Pin-type cages for cylindrical roller bearings consist of two rings and a series of pins running through the center of the rolling elements. These cages are used for large diameter cylindrical roller bearings where machined brass cages are not available. With this design, additional rollers can typically be added, resulting in increased load capacity.

Fig. 7. Pin-type cage.

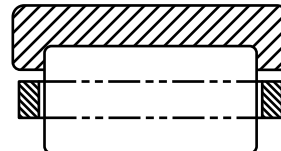

Fig. 4. One-piece finger-type cage.



Fig. 5. Two-piece brass cage.



Fig. 6. One-piece premium cage.

METRIC SYSTEM TOLERANCES

CYLINDRICAL ROLLER BEARINGS

Cylindrical roller bearings are manufactured to a number of specifications with each having classes that define tolerances on dimensions such as bore, O.D., width and runout. Metric bearings have been manufactured to corresponding standard negative tolerances.

Boundary dimension tolerances for cylindrical roller bearing usage are listed in the following tables. These tolerances are provided for use in selecting bearings for general applications in conjunction with the bearing mounting and fitting practices offered in later sections.

The following table summarizes the different specifications and classes for cylindrical roller bearings.

TABLE 2. BEARING SPECIFICATIONS AND CLASSES

System	Specification	Bearing Type	Standard Bearing Class		Precision Bearing Class			
Metric	Timken	Tapered Roller Bearings	K	N	C	B	A	AA
	ISO/DIN	All Bearing Types	P0	P6	P5	P4	P2	-
	ABMA	Cylindrical, Spherical	RBEC 1	RBEC 3	RBEC 5	RBEC 7	RBEC 9	-
		Ball Bearings	ABEC 1	ABEC 3	ABEC 5	ABEC 7	ABEC 9	-
		Tapered Roller Bearings	K	N	C	B	A	-
Inch	Timken	Tapered Roller Bearings	4	2	3	0	00	000
	ABMA	Tapered Roller Bearings	4	2	3	0	00	-

Standard Timken radial cylindrical roller bearings maintain normal tolerances according to ISO 492. Tables 3 and 4 list the critical tolerances for these radial cylindrical roller bearings. For applications where running tolerance is critical, P6 or P5 tolerances are recommended.

The term deviation is defined as the difference between a single ring dimension and the nominal dimension. For metric tolerances, the nominal dimension is at a +0 mm (0 in.) tolerance. The deviation is the tolerance range for the listed parameter. Variation is defined as the difference between the largest and smallest measurements of a given parameter for an individual ring.

TABLE 3. CYLINDRICAL ROLLER BEARING TOLERANCES – INNER RING (Metric)⁽¹⁾

Bearing Bore		Bore Deviation ⁽²⁾ Δ_{dmp}			Width Variation V_{BS}			Radial Runout K_{ia}			Face Runout with Bore S_d	Axial Runout S_{ia}	Width Deviation Inner and Outer Rings ⁽²⁾ Δ_{B_s} and Δ_{C_s}	
Over	Incl.	P0	P6	P5	P0	P6	P5	P0	P6	P5	P5	P5	P0, P6	P5
mm	mm	mm	mm	mm	mm	mm	mm	mm	mm	mm	mm	mm	mm	mm
in.	in.	in.	in.	in.	in.	in.	in.	in.	in.	in.	in.	in.	in.	in.
2.5000 0.0984	10.000 0.3937	-0.008 -0.0003	-0.007 -0.0003	-0.005 -0.0002	0.015 0.0006	0.015 0.0006	0.005 0.0002	0.010 0.0004	0.006 0.0002	0.004 0.0002	0.007 0.0003	0.007 0.0003	-0.120 -0.0047	-0.040 -0.0157
10.000 0.3937	18.000 0.7087	-0.008 -0.0003	-0.007 -0.0003	-0.005 -0.0002	0.020 0.0008	0.020 0.0008	0.005 0.0002	0.010 0.0004	0.007 0.0003	0.004 0.0002	0.007 0.0003	0.007 0.0003	-0.120 -0.0047	-0.080 -0.0031
18.000 0.7087	30.000 1.1811	-0.010 -0.0004	-0.008 -0.0003	-0.006 -0.0002	0.020 0.0008	0.020 0.0008	0.005 0.0002	0.013 0.0005	0.008 0.0003	0.004 0.0002	0.008 0.0003	0.008 0.0003	-0.120 -0.0047	-0.120 -0.0047
30.000 1.1811	50.000 1.9685	-0.012 -0.0005	-0.010 -0.0004	-0.008 -0.0003	0.020 0.0008	0.020 0.0008	0.005 0.0002	0.015 0.0006	0.010 0.0004	0.005 0.0002	0.008 0.0003	0.008 0.0003	-0.120 -0.0047	-0.120 -0.0047
50.000 1.9685	80.000 3.1496	-0.015 -0.0006	-0.012 -0.0005	-0.009 -0.0004	0.025 0.0010	0.025 0.0010	0.006 0.0002	0.020 0.0008	0.010 0.0004	0.005 0.0002	0.008 0.0003	0.008 0.0003	-0.150 -0.0059	-0.150 -0.0059
80.000 3.1496	120.000 4.7244	-0.020 -0.0008	-0.015 -0.0006	-0.010 -0.0004	0.025 0.0010	0.025 0.0010	0.007 0.0003	0.025 0.0010	0.013 0.0005	0.006 0.0002	0.009 0.0004	0.009 0.0004	-0.200 -0.0079	-0.200 -0.0079
120.000 4.7244	150.000 5.9055	-0.025 -0.0010	-0.018 -0.0007	-0.013 -0.0005	0.030 0.0012	0.030 0.0012	0.008 0.0003	0.030 0.0012	0.018 0.0007	0.008 0.0003	0.010 0.0004	0.010 0.0004	-0.250 -0.0098	-0.250 -0.0098
150.000 5.9055	180.000 7.0866	-0.025 -0.0010	-0.018 -0.0007	-0.013 -0.0005	0.030 0.0012	0.030 0.0012	0.008 0.0003	0.030 0.0012	0.018 0.0007	0.008 0.0003	0.010 0.0004	0.010 0.0004	-0.250 -0.0098	-0.250 -0.0098
180.000 7.0866	250.000 9.8425	-0.030 -0.0012	-0.022 -0.0009	-0.015 -0.0006	0.030 0.0012	0.030 0.0012	0.010 0.0004	0.040 0.0016	0.020 0.0008	0.010 0.0004	0.011 0.0004	0.013 0.0005	-0.300 -0.0018	-0.300 -0.0018
250.000 9.8425	315.000 12.4016	-0.035 -0.0014	-0.025 -0.0010	-0.018 -0.0007	0.035 0.0014	0.035 0.0014	0.013 0.0005	0.050 0.0020	0.025 0.0010	0.013 0.0005	0.013 0.0005	0.015 0.0006	-0.350 -0.0138	-0.350 -0.0138
315.000 12.4016	400.000 15.7480	-0.040 -0.0016	-0.030 -0.0012	-0.023 -0.0009	0.040 0.0016	0.040 0.0016	0.015 0.0006	0.060 0.0024	0.030 0.0012	0.015 0.0006	0.015 0.0006	0.020 0.0008	-0.400 -0.0157	-0.400 -0.0157
400.000 15.7480	500.000 19.6850	-0.045 -0.0018	-0.035 -0.0014	–	0.050 0.0020	0.045 0.0018	–	0.065 0.0026	0.035 0.0014	–	–	–	-0.450 -0.0177	–
500.000 19.6850	630.000 24.8031	-0.050 -0.0020	-0.040 -0.0016	–	0.060 0.0024	0.050 0.0020	–	0.070 0.0028	0.040 0.0016	–	–	–	-0.500 -0.0197	–
630.000 24.8031	800.000 31.4961	-0.075 -0.0030	–	–	0.070 0.0028	–	–	0.080 0.0031	–	–	–	–	-0.750 -0.0295	–

⁽¹⁾Symbol definitions are found on pages 32-33 of the Timken Engineering Manual (order no. 10424).

⁽²⁾Tolerance range is from +0 to value listed.

TABLE 4. CYLINDRICAL ROLLER BEARING TOLERANCES – OUTER RING (Metric)⁽¹⁾

Bearing O.D.		Outside Deviation ⁽²⁾ Δ_{Dmp}			Width Variation V_{cs}		Radial Runout K_{ea}			Axial Runout S_{ea}	Outside Diameter Runout With Face S_D
Over	Incl.	P0	P6	P5	P0	P6	P0	P6	P5	P5	P5
mm in.	mm in.	mm in.	mm in.	mm in.	mm in.	mm in.	mm in.	mm in.	mm in.	mm in.	mm in.
0.000 0.0000	18.000 0.7087	-0.008 -0.0003	-0.007 -0.0003	-0.005 -0.0002	0.015 0.0006	0.005 0.0002	0.015 0.0006	0.008 0.0003	0.005 0.0002	0.008 0.0003	0.008 0.0003
18.000 0.7087	30.000 1.1811	-0.009 -0.0004	-0.008 -0.0003	-0.006 -0.00024	0.020 0.0008	0.005 0.0002	0.015 0.0006	0.009 0.0004	0.006 0.00024	0.008 0.0003	0.008 0.0003
30.000 1.1811	50.000 1.9685	-0.011 -0.0004	-0.009 -0.0004	-0.007 -0.0003	0.020 0.0008	0.005 0.0002	0.020 0.0008	0.010 0.0004	0.007 0.0003	0.008 0.0003	0.008 0.0003
50.000 1.9685	80.000 3.1496	-0.013 -0.0005	-0.011 -0.0004	-0.009 -0.0004	0.025 0.0010	0.006 0.00024	0.025 0.0010	0.013 0.0005	0.008 0.0003	0.010 0.0004	0.008 0.0003
80.000 3.1496	120.000 4.7244	-0.015 -0.0006	-0.013 -0.0005	-0.010 -0.0004	0.025 0.0010	0.008 0.0003	0.035 0.0014	0.018 0.0007	0.010 0.0004	0.011 0.0004	0.009 0.0004
120.000 4.7244	150.000 5.9055	-0.018 -0.0007	-0.015 -0.0006	-0.011 -0.0004	0.030 0.0012	0.008 0.0003	0.040 0.0016	0.020 0.0008	0.011 0.0004	0.013 0.0005	0.010 0.0004
150.000 5.9055	180.000 7.0866	-0.025 -0.0010	-0.018 -0.0007	-0.013 -0.0005	0.030 0.0012	0.008 0.0003	0.045 0.0018	0.023 0.0009	0.013 0.0005	0.014 0.0006	0.010 0.0004
180.000 7.0866	250.000 9.8425	-0.030 -0.0012	-0.020 -0.0008	-0.015 -0.0006	0.030 0.0012	0.010 0.0004	0.050 0.0020	0.025 0.0010	0.015 0.0006	0.015 0.0006	0.011 0.0004
250.000 9.8425	315.000 12.4016	-0.035 -0.0014	-0.025 -0.0010	-0.018 -0.0007	0.035 0.0014	0.011 0.0004	0.060 0.0024	0.030 0.0012	0.018 0.0007	0.018 0.0007	0.013 0.0005
315.000 12.4016	400.000 15.7480	-0.040 -0.0016	-0.028 -0.0011	-0.020 -0.0008	0.040 0.0016	0.013 0.0005	0.070 0.0028	0.035 0.0014	0.020 0.0008	0.020 0.0008	0.013 0.0005
400.000 15.7480	500.000 19.6850	-0.045 -0.0018	-0.033 -0.0013	-0.023 -0.0009	0.045 0.0018	0.015 0.0006	0.080 0.0031	0.040 0.0016	0.023 0.0009	0.023 0.0009	0.015 0.0006
500.000 19.6850	630.000 24.8031	-0.050 -0.0020	-0.038 -0.0015	-0.028 -0.0011	0.050 0.0020	0.018 0.0007	0.100 0.0039	0.050 0.0020	0.025 0.0010	0.025 0.0010	0.018 0.0007
630.000 24.8031	800.000 31.4961	-0.075 -0.0030	-0.045 -0.0018	-0.035 -0.0014	– –	0.020 0.0008	0.120 0.0047	0.060 0.0024	0.030 0.0012	0.030 0.0012	0.020 0.0008
800.000 31.4961	1000.000 39.3701	-0.100 -0.0040	-0.060 -0.0024	– –	– –	– –	0.140 0.0055	0.075 0.0030	– –	– –	– –
1000.000 39.3701	1250.000 49.2126	-0.125 -0.0050	– –	– –	– –	– –	0.160 0.0063	– –	– –	– –	– –

⁽¹⁾Symbol definitions are found on pages 32-33 of the Timken Engineering Manual (order no. 10424).

⁽²⁾Tolerance range is from +0 to value listed.

CYLINDRICAL ROLLER BEARING MOUNTING, FITTING, SETTING AND INSTALLATION

MOUNTING

Cylindrical roller bearings can be mounted individually, but most often are mounted in combination with another cylindrical roller, a spherical roller or a tapered roller bearing.

Fig. 8 shows a pulverizer wheel assembly where a two-row spherical roller bearing is mounted in combination with a cylindrical roller bearing. In this application, the cylindrical roller bearing allows the shaft to float relative to the housing.

Fig. 9 shows a single-reduction gear reducer with herringbone gears. A tapered roller bearing is mounted in combination with a cylindrical roller bearing on the upper shaft, and two cylindrical bearings are mounted on the lower shaft.

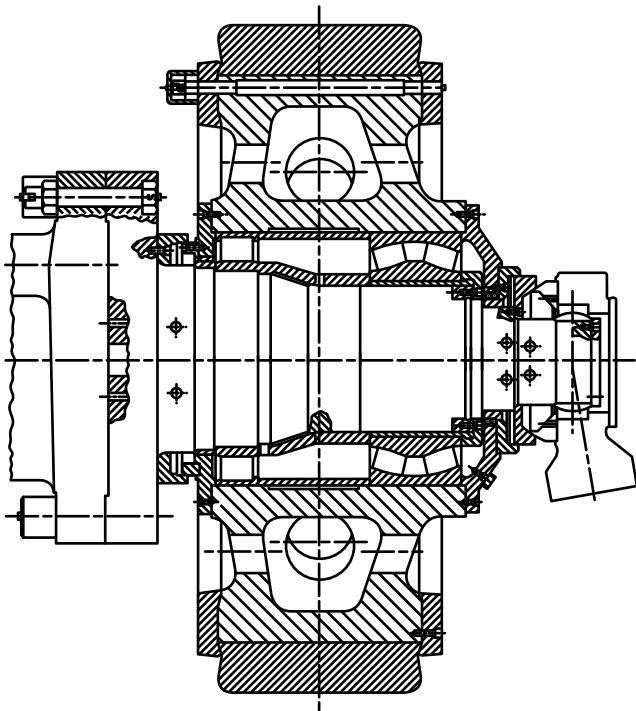

Fig. 8. Pulverizer wheel assembly.

FITTING PRACTICE

Tables 6-18 on pages 22-39 list the recommended fitting practice for cylindrical roller bearings. The tables assume:

- The bearing is of normal precision.
- The housing is thick and made from steel or cast iron.
- The shaft is solid and made from steel.
- The bearing seats are ground or accurately turned to less than approximately 1.6 μm Ra finish.

The suggested fit symbols are in accordance with ISO 286. For help with recommended fitting practices, contact your Timken representative.

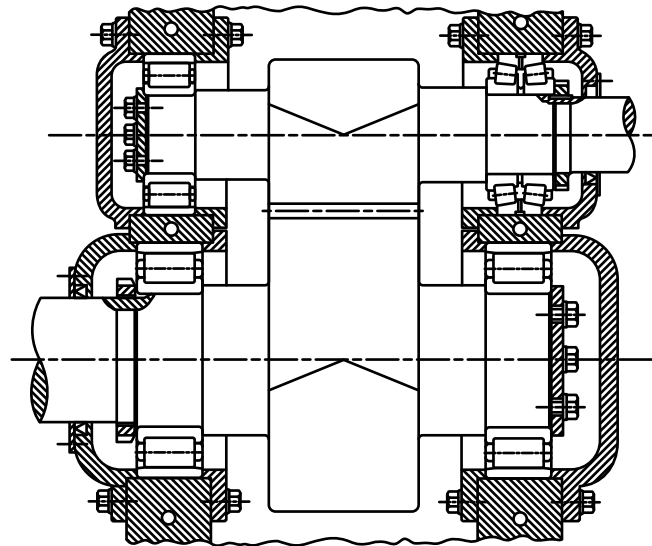

Fig. 9. Single-reduction gear reducer.

⚠ WARNING

Failure to observe the following warnings could create a risk of death or serious injury.

Proper maintenance and handling practices are critical. Always follow installation instructions and maintain proper lubrication.

Never spin a bearing with compressed air. The rollers may be forcefully expelled.

As a general guideline, rotating inner rings should be applied with an interference fit. Loose fits may permit the inner rings to creep or turn and wear the shaft and the backing shoulder. This wear may result in excessive bearing looseness and possible bearing and shaft damage. Additionally, abrasive metal particles resulting from creep or turning may enter into the bearing and cause damage and vibration.

Stationary inner-ring fitting practice depends on the loading of the application. The load conditions and bearing envelope dimensions should be used to select the suggested shaft fit from the tables.

Similarly, rotating outer-ring applications should use an interference fit between the outer ring and housing.

Stationary outer rings are generally mounted with loose fits to permit assembly and disassembly.

Thin-walled housings, light-alloy housings or hollow shafts must use press fits tighter than required for thick-walled housings, steel or cast iron housings or solid shafts. Tighter fits also are required when mounting the bearing on relatively rough, or unground surfaces.

SETTING

To achieve appropriate operation clearance, attention must be paid to the effects fitting practice and thermal gradients have within the bearing.

FITTING PRACTICE

- An interference fit between the inner ring and a solid steel shaft will reduce the radial clearance within the bearing by approximately 85 percent of the fit.
- Interference fits between the outer ring and steel or cast iron housing will reduce radial clearance by approximately 60 percent.

THERMAL GRADIENTS

- Thermal gradients within the bearing are primarily a function of the bearing rotational speed. As speed increases, thermal gradients increase, thermal growth occurs and the radial clearance is reduced.
- As a rule of thumb, radial clearance should be increased for speeds in excess of 70 percent of the speed rating.

For help selecting the correct radial internal clearance for your application, consult with your Timken representative.

Radial internal clearance tolerances are listed in table 5.

Cylindrical roller bearings are ordered with a specified standard or non-standard radial internal clearance value. The standard radial internal clearances are designated as C2, C0 (normal), C3, C4 or C5 and are in accordance with ISO 5753. C2 represents the minimum clearance and C5 represents the maximum clearance. Non-standardized values also are available by special request.

The clearance required for a given application depends on the desired operating precision, the rotational speed of the bearing, and the fitting practice used. Most applications use a normal or C3 clearance. Typically, larger clearance reduces the operating load zone of the bearing, increases the maximum roller load and reduces the bearing's expected life. However, a cylindrical roller bearing that has been put into a preload condition can experience premature bearing damage caused by excessive heat generation and/or material fatigue. As a general guideline, cylindrical roller bearings should not operate in a preloaded condition.

TABLE 5. RADIAL INTERNAL CLEARANCE LIMITS – CYLINDRICAL ROLLER BEARINGS – CYLINDRICAL BORE

Bore (Nominal)		Bore – RIC									
Over	Incl.	C2		C0		C3		C4		C5	
mm	mm	Min.	Max.	Min.	Max.	Min.	Max.	Min.	Max.	Min.	Max.
in.	in.	mm	mm	mm	mm	mm	mm	mm	mm	mm	mm
in.	in.	in.	in.	in.	in.	in.	in.	in.	in.	in.	in.
–	10	0.000	0.025	0.020	0.0045	0.035	0.060	0.050	0.075	–	–
–	0.3937	0.0000	0.0010	0.0008	0.0018	0.0014	0.0024	0.0020	0.0030	–	–
10	24	0.000	0.025	0.020	0.0045	0.035	0.060	0.050	0.075	0.065	0.090
0.3937	0.9449	0.0000	0.0010	0.0008	0.0018	0.0014	0.0024	0.0020	0.0030	0.0026	0.0035
24	30	0.000	0.025	0.020	0.0045	0.035	0.060	0.050	0.075	0.070	0.095
0.9449	1.1811	0.0000	0.0010	0.0008	0.0018	0.0014	0.0024	0.0020	0.0030	0.0028	0.0037
30	40	0.005	0.030	0.025	0.050	0.0045	0.070	0.060	0.085	0.080	0.105
1.1811	1.5748	0.0002	0.0012	0.0010	0.0020	0.0018	0.0028	0.0024	0.0033	0.0031	0.0041
40	50	0.005	0.035	0.030	0.060	0.050	0.080	0.070	0.100	0.095	0.125
1.5748	1.9685	0.0002	0.0014	0.0012	0.0024	0.0020	0.0031	0.0028	0.0039	0.0037	0.0049
50	65	0.010	0.040	0.040	0.070	0.060	0.090	0.080	0.110	0.110	0.140
1.9685	2.5591	0.0004	0.0016	0.0016	0.0028	0.0024	0.0035	0.0031	0.0043	0.0043	0.0055
65	80	0.010	0.045	0.040	0.075	0.065	0.100	0.090	0.125	0.130	0.165
2.5591	3.1496	0.0004	0.0018	0.0016	0.0030	0.0026	0.0039	0.0035	0.0049	0.0051	0.0065
80	100	0.015	0.050	0.050	0.085	0.075	0.110	0.105	0.140	0.155	0.190
3.1496	3.9370	0.0006	0.0020	0.0020	0.0033	0.0030	0.0043	0.0041	0.0055	0.0061	0.0075
100	120	0.015	0.055	0.050	0.090	0.085	0.125	0.125	0.165	0.180	0.220
3.9370	4.7244	0.0006	0.0022	0.0020	0.0035	0.0033	0.0049	0.0049	0.0065	0.0071	0.0087
120	140	0.015	0.060	0.060	0.105	0.100	0.145	0.145	0.190	0.200	0.245
4.7244	5.5118	0.0006	0.0024	0.0024	0.0041	0.0039	0.0057	0.0057	0.0075	0.0079	0.0096
140	160	0.020	0.070	0.070	0.120	0.115	0.165	0.165	0.215	0.225	0.275
5.5118	6.2992	0.0008	0.0028	0.0028	0.0047	0.0045	0.0065	0.0065	0.0085	0.0089	0.0108
160	180	0.025	0.075	0.075	0.125	0.120	0.170	0.170	0.220	0.250	0.300
6.2992	7.0866	0.0010	0.0030	0.0030	0.0049	0.0047	0.0067	0.0067	0.0087	0.0098	0.0118
180	200	0.035	0.090	0.090	0.145	0.140	0.195	0.195	0.250	0.275	0.330
7.0866	7.8740	0.0014	0.0035	0.0035	0.0057	0.0055	0.0077	0.0077	0.0098	0.0108	0.0130
200	225	0.045	0.105	0.105	0.165	0.160	0.220	0.220	0.280	0.305	0.365
7.8740	8.8583	0.0018	0.0041	0.0041	0.0065	0.0063	0.0087	0.0087	0.0110	0.0120	0.0144
225	250	0.045	0.110	0.110	0.175	0.170	0.235	0.235	0.300	0.330	0.395
8.8583	9.8425	0.0018	0.0043	0.0043	0.0069	0.0067	0.0093	0.0093	0.0118	0.0130	0.0156
250	280	0.055	0.125	0.125	0.195	0.190	0.260	0.260	0.330	0.370	0.440
9.8425	11.0236	0.0022	0.0049	0.0049	0.0077	0.0075	0.0102	0.0102	0.0130	0.0146	0.0173
280	315	0.055	0.130	0.130	0.205	0.200	0.275	0.275	0.350	0.410	0.485
11.0236	12.4016	0.0022	0.0051	0.0051	0.0081	0.0079	0.0108	0.0108	0.0138	0.0161	0.0191
315	355	0.065	0.145	0.145	0.225	0.225	0.305	0.305	0.385	0.455	0.535
12.4016	13.9764	0.0026	0.0057	0.0057	0.0089	0.0089	0.0120	0.0120	0.0152	0.0179	0.0211
355	400	0.100	0.190	0.190	0.280	0.280	0.370	0.370	0.460	0.510	0.600
13.9764	15.7480	0.0039	0.0075	0.0075	0.0110	0.0110	0.0146	0.0146	0.0181	0.0201	0.0236
400	450	0.110	0.210	0.210	0.310	0.310	0.410	0.410	0.510	0.565	0.665
15.7480	17.7165	0.0043	0.0083	0.0083	0.0122	0.0122	0.0161	0.0161	0.0201	0.0222	0.0262
450	500	0.110	0.220	0.220	0.330	0.330	0.440	0.440	0.550	0.625	0.735
17.7165	19.6850	0.0043	0.0087	0.0087	0.0130	0.0130	0.0173	0.0173	0.0217	0.0246	0.0289
500	560	0.120	0.240	0.240	0.360	0.360	0.480	0.480	0.600	0.690	0.810
19.6850	22.0472	0.0047	0.0095	0.0095	0.0142	0.0142	0.0189	0.0189	0.0236	0.0272	0.0319
560	630	0.140	0.260	0.260	0.380	0.380	0.500	0.500	0.620	0.780	0.900
22.0472	24.8031	0.0055	0.0102	0.0102	0.0150	0.0150	0.0197	0.0197	0.0244	0.0307	0.0354
630	710	0.145	0.285	0.285	0.425	0.425	0.565	0.565	0.705	0.865	1.005
24.8031	27.9528	0.0057	0.0112	0.0112	0.0167	0.0167	0.0222	0.0222	0.0278	0.0341	0.0396
710	800	0.150	0.310	0.310	0.470	0.470	0.630	0.630	0.790	0.975	1.135
27.9528	31.4961	0.0059	0.0122	0.0122	0.0185	0.0185	0.0248	0.0248	0.0311	0.0384	0.0447
800	900	0.180	0.350	0.350	0.520	0.520	0.690	0.690	0.860	1.095	1.265
31.4961	35.4331	0.0071	0.0138	0.0138	0.0205	0.0205	0.0272	0.0272	0.0339	0.0431	0.0498
900	1000	0.200	0.390	0.390	0.580	0.580	0.770	0.770	0.960	1.215	1.405
35.4331	39.3701	0.0079	0.0154	0.0154	0.0228	0.0228	0.0303	0.0303	0.0378	0.0478	0.0553

Shaft fit RIC reductions and clearance:

For a 150 mm nominal bore at C3, the RIC will be 0.115 to 0.165 mm (0.0045 to 0.0065 in.). Recalculating shaft fit RIC reduction and clearance:

$$\begin{aligned} \text{max. clearance} &= \text{max. RIC} - \text{min. fit reduction} \\ &= 0.165 - 0.034 = 0.131 \text{ mm (0.0052 in.)} \end{aligned}$$

$$\begin{aligned} \text{min. clearance} &= \text{min. RIC} - \text{max. fit reduction} \\ &= 0.115 - 0.074 = 0.041 \text{ mm (0.0016 in.)} \end{aligned}$$

Since the minimum mounted clearance is less than the minimum suggested RIC of 0.056 mm (0.0022 in.), the C3 RIC clearance limit needs to be reevaluated.

INSTALLATION

When using a tight-fit inner ring, the method of assembly will depend on whether the bearing has a cylindrical or tapered bore.

Mounting cylindrical bore bearings

Heat expansion method

- Most applications require a tight interference fit on the shaft.
- Mounting is simplified by heating the bearing to expand it sufficiently to slide easily onto the shaft.
- Two methods of heating are commonly used:
 - Tank of heated oil.
 - Induction heating.
- The first is accomplished by heating the bearing in a tank of oil that has a high flash point.
- The oil temperature should not be allowed to exceed 121° C (250° F). A temperature of 93° C (200° F) is sufficient for most applications.
- The bearing should be heated for 20 or 30 minutes, or until it is expanded sufficiently to slide onto the shaft easily.
- The induction heating process can be used for mounting bearings.
- Induction heating is rapid. Care must be taken to prevent bearing temperature from exceeding 93° C (200° F).
- Trial runs with the unit and bearing are usually necessary to obtain proper timing.
- Thermal crayons melted at predetermined temperatures can be used to check the bearing temperature.
- While the bearing is hot, it should be positioned squarely against the shoulder.

NOTE

Never use steam or hot water when cleaning the bearings because these methods can create rust or corrosion.

NOTE

Never expose any surface of a bearing to the flame of a torch.

NOTE

Do not heat bearing beyond 149° C (300° F).

- Lockwashers and locknuts or clamping plates are then installed to hold the bearing against the shoulder of the shaft.
- As the bearing cools, the locknut or clamping plate should be tightened.
- In cases of outer ring rotation, where the outer ring is a tight fit in the housing, the housing member can be expanded by heating.
- The oil bath is shown in fig. 10. The bearing should not be in direct contact with the heat source.
- The usual arrangement is to have a screen several inches from the bottom of the tank. Small support blocks separate the bearing from the screen.
- It is important to keep the bearing away from any localized high-heat source that may raise its temperature excessively, resulting in ring hardness reduction.

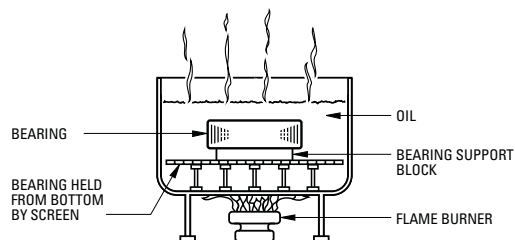

Fig. 10. Heat expansion method.

- Flame-type burners are commonly used. An automatic device for temperature control is desirable.
- If safety regulations prevent the use of an open heated oil bath, a mixture of 15 percent soluble-oil water may be used. This mixture may be heated to a maximum of 93° C (200° F) without being flammable.

CAUTION

Failure to observe the following warnings could create a risk of death or serious injury.

Remove oil or rust inhibitor from parts before heating, to avoid fire and fumes.

Arbor press method

- An alternate method of mounting, generally used only on smaller size bearings, is to press the bearing onto the shaft or into the housing. This can be done by using an arbor press and a mounting tube as shown in fig. 11.
- The tube should be made from soft steel with an inside diameter slightly larger than the shaft.
- The O.D. of the tube should not exceed the shaft backing diameter given in the Timken® Spherical Roller Bearing Catalog (order no. 10446), found on timken.com/catalogs.

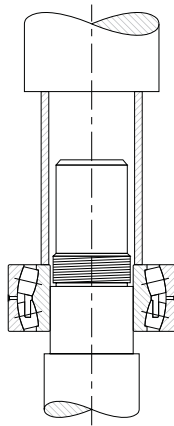

Fig. 11. Arbor press method.

- The tube should be faced square at both ends. It should be thoroughly clean inside and out, and long enough to clear the end of the shaft after the bearing is mounted.
- If the outer ring is being pressed into the housing, the O.D. of the mounting tube should be slightly smaller than the housing bore. The I.D. should not be less than the suggested housing backing diameter in the table of dimensions available in the Timken Spherical Roller Bearing Catalog (order no. 10446), found on timken.com/catalogs.
- Coat the shaft with a light machine oil to reduce the force needed for a press fit.
- Carefully place the bearing on the shaft, making sure it is square with the shaft axis.
- Apply steady pressure from the arbor ram to drive the bearing firmly against the shoulder.

NOTE

Never attempt a press fit on a shaft by applying pressure to the outer ring or a press fit in a housing by applying pressure to the inner ring.

SHAFT AND HOUSING FITS

CYLINDRICAL ROLLER BEARINGS

TABLE 6. CYLINDRICAL ROLLER BEARINGS SHAFT FITS (EXCEPT 5200 SERIES AND FOUR-ROW CYLINDRICALS)

Load Limit		Shaft Diameter		Shaft Tolerance
Lower	Upper	mm in.	mm in.	Symbol ⁽¹⁾
INNER RING STATIONARY				
0	C ⁽²⁾	All	All	g6
0	C	All	All	h6
INNER RING ROTATION OR INDETERMINATE				
		Over	Incl.	
0	0.08C	0	40	k6 ⁽³⁾
		0	1.57	
		40	140	m6 ⁽⁴⁾
		1.57	5.51	
		140	320	n6
		5.51	12.60	
		320	500	p6
		12.60	19.68	
		500	—	—
		19.68	—	—
0.08C	0.18C	0	40	k5
		0	1.57	
		40	100	m5
		1.57	3.94	
		100	140	m6
		3.94	5.51	
		140	320	n6
		5.51	12.60	
		320	500	p6
		12.60	19.68	
0.18C	C	0	40	m5 ⁽⁵⁾
		0	1.57	
		40	65	m6 ⁽⁵⁾
		1.57	2.56	
		65	140	n6 ⁽⁵⁾
		2.56	5.51	
		140	320	p6 ⁽⁵⁾
		5.51	12.60	
		320	500	r6 ⁽⁵⁾
		12.60	19.68	
500	—	r7 ⁽⁵⁾		
19.68	—	—		
THRUST LOADS				

Not suggested, consult your Timken engineer.

⁽¹⁾For solid shaft. See pages 24-29 for tolerance values.

⁽²⁾C = dynamic load rating.

⁽³⁾Use k5 for high-precision applications.

⁽⁴⁾Use m5 for high-precision applications.

⁽⁵⁾Bearings with greater than nominal clearance must be used.

TABLE 7. FOUR-ROW CYLINDRICAL ROLLER BEARING SHAFTS

Load Limit		Shaft Diameter		Shaft Tolerance
Lower	Upper	mm in.	mm in.	Symbol ⁽¹⁾
All		100	120	n6
		3.93	4.72	
		120	225	p6
		4.72	8.85	
All		225	400	r6
		8.85	15.75	
All		400	—	s6
		15.75	—	

⁽¹⁾For solid shaft. See pages 24-29 for tolerance values.

TABLE 8. CYLINDRICAL ROLLER BEARING HOUSING FITS

	Operating Conditions	Examples	Housing Tolerance Symbol ⁽¹⁾	Outer Ring Displaceable Axially	
	OUTER RING ROTATING				
	Heavy loads with thin-walled housing	Crane support wheels Wheel hubs (roller bearings) Crank bearings	P6	No	
	Normal to heavy loads	Wheel hubs (ball bearings) Crank bearings	N6	No	
	Light loads	Conveyor rollers Rope sheaves Tension pulleys	M6	No	
	INDETERMINATE LOAD DIRECTION				
	Heavy shock loads	Electric traction motors	M7	No	
	Normal to heavy loads, axial displacement of outer ring not required.	Electric motors Pumps Crankshaft main bearings	K6	No, normally	
Below this line, housing can either be one piece or split. Above this line, a split housing is not suggested.	Light to normal loads, axial displacement of outer ring desired.	Electric motors Pumps Crankshaft main bearings	J6	Yes, normally	
	OUTER RING STATIONARY				
	Shock loads, temporary complete unloading	Heavy rail vehicles	J6	Yes, normally	
	All	One-piece housing	General applications Heavy rail vehicles	H6	Easily
		Radially split housing	Transmission drives	H7	Easily
	Heat supplied through shaft	Dryer cylinders	G7	Easily	

⁽¹⁾Cast iron steel housing. See pages 30-37 for numerical values. Where wider tolerances are permissible, P7, N7, M7, K7, J7 and H7 values may be used in place of P6, N6, M6, K6, J6 and H6 values, respectively.

SHAFT AND HOUSING FITS

These charts are guidelines for specifying shaft and housing fits related to particular operating conditions. Please contact your Timken engineer for more information.

RADIAL BALL, SPHERICAL ROLLER AND CYLINDRICAL ROLLER BEARINGS
SHAFT TOLERANCES

TABLE 9. RADIAL BALL, SPHERICAL AND CYLINDRICAL ROLLER BEARING SHAFT TOLERANCES

Bearing Bore			g6			h6			h5			j5		
Nominal (Max.) Over Incl.		Tolerance ⁽¹⁾	Shaft Diameter		Fit	Shaft Diameter		Fit	Shaft Diameter		Fit	Shaft Diameter		Fit
mm	mm	mm	mm	mm	mm	mm	mm	mm	mm	mm	mm	mm	mm	mm
in.	in.	in.	in.	in.	in.	in.	in.	in.	in.	in.	in.	in.	in.	in.
3.000 0.1181	6.000 0.2362	-0.008 -0.003	-0.004 -0.0002	-0.012 -0.0005	0.012L 0.004T 0.0005L 0.0001T	0.000 0.0000	-0.008 -0.003	0.008T 0.0003L 0.0003T	0.000 0.0000	-0.005 -0.0002	0.008T 0.0002L 0.0003T	+0.003 +0.0001	-0.002 -0.0001	0.002L 0.011T 0.0001L 0.0004T
6.000 0.2362	10.000 0.3937	-0.008 -0.003	-0.005 -0.0002	-0.014 -0.0006	0.014L 0.003T 0.0006L 0.0001T	0.000 0.0000	-0.009 -0.0004	0.008T 0.0004L 0.0003T	0.000 0.0000	-0.006 -0.0002	0.006L 0.008T 0.0002L 0.0003T	+0.004 +0.0002	-0.002 -0.0001	0.002L 0.012T 0.0001L -0.0005T
10.000 0.3937	18.000 0.7087	-0.008 -0.003	-0.006 -0.0002	-0.017 -0.0007	0.017L 0.002T 0.0007L -0.0001T	0.000 0.0000	-0.011 -0.0004	0.011L 0.008T 0.0004L 0.0003T	0.000 0.0000	-0.008 -0.0003	0.008L 0.008T 0.0003L 0.0003T	+0.005 +0.0002	-0.003 -0.0001	0.003L 0.013T 0.0001L 0.0005T
18.000 0.7087	30.000 1.1811	-0.010 -0.0004	-0.007 -0.0003	-0.020 -0.0008	0.020L 0.003T 0.0008L 0.0001T	0.000 0.0000	-0.013 -0.0005	0.013L 0.010T 0.0005L 0.0004T	-	-	-	+0.005 +0.0002	-0.004 -0.0002	0.004L 0.015T 0.0002L 0.0006T
30.000 1.1811	50.000 1.9685	-0.014 -0.0006	-0.009 -0.0004	-0.025 -0.0010	0.025L 0.003T 0.0010L 0.0001T	0.000 0.0000	-0.016 -0.0006	0.016L 0.012T 0.0006L 0.0005T	-	-	-	+0.006 +0.0002	-0.005 -0.0002	0.005L 0.018T 0.0002L 0.0007T
50.000 1.9685	80.000 3.1496	-0.015 -0.0006	-0.010 -0.0004	-0.029 -0.0011	0.029L 0.005T 0.0011L 0.0002T	0.000 0.0000	-0.019 -0.0007	0.019L 0.015T 0.0007L 0.0006T	-	-	-	+0.006 +0.0002	-0.007 -0.0003	0.007L 0.021T 0.0003L 0.0008T
80.000 3.1496	120.000 4.7244	-0.020 -0.0008	-0.012 -0.0005	-0.034 -0.0013	0.034L 0.008T 0.0013L 0.0003T	0.000 0.0000	-0.022 -0.0009	0.022L 0.020T 0.0009L 0.0008T	-	-	-	+0.006 +0.0002	-0.009 -0.0004	0.009L 0.026T 0.0004L 0.0010T
120.000 4.7244	180.000 7.0866	-0.025 -0.0010	-0.014 -0.0006	-0.039 -0.0015	0.039L 0.011T 0.0015L 0.0004T	0.000 0.0000	-0.025 -0.0010	0.025L 0.025T 0.0010L 0.0010T	-	-	-	+0.007 +0.0003	-0.011 -0.0004	0.011L 0.032T 0.0004L 0.0013T
180.000 7.0866	200.000 7.8740	-0.030 -0.0012	-0.015 -0.0006	-0.044 -0.0017	0.044T 0.015T 0.0017L 0.0006T	0.000 0.0000	-0.029 -0.0011	0.029L 0.030T 0.0011L 0.0012T	-	-	-	+0.007 +0.0003	-0.013 -0.0005	0.013L 0.037T 0.0005L 0.0015T
200.000 7.8740	225.000 8.8583	-0.030 -0.0012	-0.015 -0.0006	-0.044 -0.0017	0.044T 0.015T 0.0017L 0.0006T	0.000 0.0000	-0.029 -0.0011	0.029L 0.030T 0.0011L 0.0012T	-	-	-	+0.007 +0.0003	-0.013 -0.0005	0.013L 0.037T 0.0005L 0.0015T
225.000 8.8583	250.000 9.8425	-0.030 -0.0012	-0.015 -0.0006	-0.044 -0.0017	0.044T 0.015T 0.0017L 0.0006T	0.000 0.0000	-0.029 -0.0011	0.029L 0.030T 0.0011L 0.0012T	-	-	-	+0.007 +0.0003	-0.013 -0.0005	0.013L 0.037T 0.0005L 0.0015T
250.000 9.8425	280.000 11.0236	-0.035 -0.0014	-0.017 -0.0007	-0.049 -0.0019	0.049L 0.018T 0.0019L 0.0007T	0.000 0.0000	-0.032 -0.0013	0.032L 0.035T 0.0013L 0.0014T	-	-	-	+0.007 +0.0003	-0.016 -0.0006	0.016L 0.042T 0.0006L 0.0017T
280.000 11.0236	315.000 12.4016	-0.035 -0.0014	-0.017 -0.0007	-0.049 -0.0019	0.049L 0.018T 0.0019L 0.0007T	0.000 0.0000	-0.032 -0.0013	0.032L 0.035T 0.0013L 0.0014T	-	-	-	+0.007 +0.0003	-0.016 -0.0006	0.016L 0.042T 0.0006L 0.0017T

NOTE: Tolerance and shaft diameters are shown in the table as variances from nominal bearing bore.

⁽¹⁾Tolerance range is from +0 to value listed.

These charts are guidelines for specifying shaft and housing fits related to particular operating conditions. Please contact your Timken engineer for more information.

j6			k5			k6			m5		
Shaft Diameter		Fit	Shaft Diameter		Fit	Shaft Diameter		Fit	Shaft Diameter		Fit
Max.	Min.	mm in.	Max.	Min.	mm in.	Max.	Min.	mm in.	Max.	Min.	mm in.
+0.006 +0.0002	-0.002 -0.0001	0.002L 0.014T 0.0001L 0.0005T	+0.006 +0.0002	+0.001 +0.0000	0.001T 0.014T 0.0000T 0.0005T	-	-	-	+0.009 +0.0004	+0.004 +0.0002	0.004T 0.017T 0.0002T 0.0007T
+0.007 +0.0003	-0.002 -0.0001	0.002L 0.015T 0.0001L 0.0006T	+0.007 +0.0003	+0.001 +0.0000	0.001T 0.015T 0.0000T 0.0006T	-	-	-	+0.012 +0.0005	+0.006 +0.0002	0.006T 0.020T 0.0002T 0.0008T
+0.008 +0.0003	-0.003 -0.0001	0.003L 0.016T 0.0001L 0.0006T	+0.009 +0.0004	+0.001 +0.0000	0.001T 0.017T 0.0000T 0.0007T	-	-	-	+0.015 +0.0006	+0.007 +0.0003	0.007T 0.023T 0.0003T 0.0009T
+0.009 +0.0004	-0.004 -0.0002	0.004L 0.019T 0.0002L 0.0008T	+0.011 +0.0004	+0.002 +0.0001	0.002T 0.021T 0.0001T 0.0008T	-	-	-	+0.017 +0.0007	+0.008 +0.0003	0.008T 0.027T 0.0003T 0.0011T
+0.011 +0.0004	-0.005 -0.0002	0.005L 0.023T 0.0002L 0.00085T	+0.013 +0.0005	+0.002 +0.0001	0.002T 0.025T 0.0001T 0.0010T	+0.018 +0.0007	+0.002 +0.0001	0.002T 0.030T 0.0001T 0.0012T	+0.020 +0.0008	+0.009 +0.0004	0.009T 0.032T 0.0004T 0.00125T
+0.012 +0.0005	-0.007 -0.0003	0.007L 0.027T 0.0003L 0.0011T	+0.015 +0.0006	+0.002 +0.0001	0.002T 0.030T 0.0001T 0.0012T	+0.021 +0.0008	+0.002 +0.0001	0.002T 0.036T 0.0001T 0.0014T	+0.024 +0.0009	+0.011 +0.0004	0.011T 0.039T 0.0004T 0.0015T
+0.013 +0.0005	-0.009 -0.0004	0.009L 0.033T 0.0004L 0.0013T	+0.018 +0.0007	+0.003 +0.0001	0.003T 0.038T 0.0001T 0.0015T	+0.025 +0.0010	+0.003 +0.0001	0.003T 0.045T 0.0001T 0.0018T	+0.028 +0.0011	+0.013 +0.0005	0.013T 0.048T 0.0005T 0.0019T
+0.014 +0.0006	-0.011 -0.0004	0.011L 0.039T 0.0004L 0.0016T	+0.021 +0.0008	+0.003 +0.0001	0.003T 0.046T 0.0001T 0.0018T	+0.028 +0.0011	+0.003 +0.0001	0.003T 0.053T 0.0001T 0.0021T	+0.033 +0.0013	+0.015 +0.0006	0.015T 0.058T 0.0006T 0.0023T
+0.016 +0.0006	-0.013 -0.0005	0.013L 0.046T 0.0005L 0.0018T	+0.024 +0.0009	+0.004 +0.0002	0.004T 0.054T 0.0002T 0.0021T	-	-	-	+0.037 +0.0015	+0.017 +0.0007	0.017T 0.067T 0.0007T 0.0027T
+0.016 +0.0006	-0.013 -0.0005	0.013L 0.046T 0.0005L 0.0018T	+0.024 +0.0009	+0.004 +0.0002	0.004T 0.054T 0.0002T 0.0021T	-	-	-	+0.037 +0.0015	+0.017 +0.0007	0.017T 0.067T 0.0007T 0.0027T
+0.016 +0.0006	-0.013 -0.0005	0.013L 0.046T 0.0005L 0.0018T	+0.024 +0.0009	+0.004 +0.0002	0.004T 0.054T 0.0002T 0.0021T	-	-	-	+0.037 +0.0015	+0.017 +0.0007	0.017T 0.067T 0.0007T 0.0027T
+0.016 +0.0006	-0.016 -0.0006	0.016L 0.051T 0.0006L 0.0020T	+0.027 +0.0011	+0.004 +0.0002	0.004T 0.062T 0.0002T 0.0025T	-	-	-	+0.043 +0.0017	+0.020 +0.0008	0.020T 0.078T 0.0008T 0.0031T
+0.016 +0.0006	-0.016 -0.0006	0.016L 0.051T 0.0006L 0.0020T	+0.027 +0.0011	+0.004 +0.0002	0.004T 0.062T 0.0002T 0.0025T	-	-	-	+0.043 +0.0017	+0.020 +0.0008	0.020T 0.078T 0.0008T 0.0031T

Continued on next page.

SHAFT AND HOUSING FITS

These charts are guidelines for specifying shaft and housing fits related to particular operating conditions. Please contact your Timken engineer for more information.

Table 9 continued.

Bearing Bore			g6			h6			h5			j5		
Nominal (Max.) Over Incl.		Tolerance ⁽¹⁾	Shaft Diameter		Fit	Shaft Diameter		Fit	Shaft Diameter		Fit	Shaft Diameter		Fit
mm	mm	mm	mm	mm	mm	mm	mm	mm	mm	mm	mm	mm	mm	mm
in.	in.	in.	in.	in.	in.	in.	in.	in.	in.	in.	in.	in.	in.	in.
315.000 12.4016	355.000 13.9764	-0.040 -0.0016	-0.018 -0.0007	-0.054 -0.0021	0.054L 0.022T 0.0021L 0.0009T	0.000 0.0000	-0.036 -0.0014	0.040T 0.0014L 0.0016T	-	-	-	+0.007 +0.0003	-0.018 -0.0007	0.018L 0.047T 0.0007L 0.0019T
355.000 13.9764	400.000 15.7480	-0.040 -0.0016	-0.018 -0.0007	-0.054 -0.0021	0.054L 0.022T 0.0021L 0.0009T	0.000 0.0000	-0.036 -0.0014	0.040T 0.0014L 0.0016T	-	-	-	+0.007 +0.0003	-0.018 -0.0007	0.018L 0.047T 0.0007L 0.0019T
400.000 15.7480	450.000 17.7165	-0.045 -0.0018	-0.020 -0.0008	-0.060 -0.0024	0.060L 0.025T 0.0024L 0.0010T	0.000 0.0000	-0.040 -0.0016	0.040L 0.045T 0.0016L 0.0018T	-	-	-	+0.007 +0.0003	-0.020 -0.0008	0.020L 0.052T 0.0008L 0.0021T
450.000 17.7165	500.000 19.6850	-0.045 -0.0018	-0.020 -0.0008	-0.060 -0.0024	0.060L 0.025T 0.0024L 0.0010T	0.000 0.0000	-0.040 -0.0016	0.040L 0.045T 0.0016L 0.0018T	-	-	-	+0.007 +0.0003	-0.020 -0.0008	0.020L 0.052T 0.0008L 0.0020T
500.000 19.6850	560.000 22.0472	-0.050 -0.0020	-0.022 -0.0009	-0.066 -0.0026	0.066L 0.028T 0.0026L 0.0011T	0.000 0.0000	-0.044 -0.0017	0.044L 0.050T 0.0017L 0.0020T	-	-	-	+0.008 0.0003	-0.022 -0.0009	0.022L 0.058T 0.0009L 0.0023T
560.000 22.0472	630.000 24.8032	-0.050 -0.0020	-0.022 -0.0009	-0.066 -0.0026	0.066L 0.028T 0.0026L 0.0011T	0.000 0.0000	-0.044 -0.0017	0.044L 0.050T 0.0017L 0.0020T	-	-	-	+0.008 +0.0003	-0.022 -0.0009	0.022L 0.058T 0.0009L 0.0023T
630.000 24.8032	710.000 27.9528	-0.075 -0.0030	-0.024 -0.0009	-0.074 -0.0029	0.074L 0.051T 0.0029L 0.0021T	0.000 0.0000	-0.050 -0.0020	0.050L 0.075T 0.0020L 0.0030T	-	-	-	+0.010 +0.0004	-0.025 -0.0010	0.025L 0.085T 0.0010L 0.0035T
710.000 27.9528	800.000 31.4961	-0.075 -0.0030	-0.024 -0.0009	-0.074 -0.0029	0.074L 0.051T 0.0029L 0.0021T	0.000 0.0000	-0.050 -0.0020	0.050L 0.075T 0.0020L 0.0030T	-	-	-	+0.010 +0.0004	-0.025 -0.0010	0.025L 0.085T 0.0010L 0.0035T
800.000 31.4961	900.000 35.4331	-0.100 -0.0039	-0.026 -0.0010	-0.082 0.0032	0.082L 0.074T 0.0032L 0.0029T	0.000 0.0000	-0.056 -0.0022	0.056L 0.100T 0.0022L 0.0039T	-	-	-	+0.012 +0.0005	-0.028 -0.0011	0.028L 0.112T 0.0011L 0.0044T
900.000 35.4331	1000.000 39.3701	-0.100 -0.0039	-0.026 -0.0010	-0.082 0.0032	0.082L 0.074T 0.0032L 0.0029T	0.000 0.0000	-0.056 -0.0022	0.056L 0.100T 0.0022L 0.0039T	-	-	-	+0.012 +0.0005	-0.028 -0.0011	0.028L 0.112T 0.0011L 0.0044T
1000.000 39.3701	1120.000 44.0945	-0.125 -0.0049	-0.028 -0.0011	-0.094 -0.0037	0.094L 0.097T 0.0037L 0.0038T	0.000 0.0000	-0.066 -0.0026	0.066L 0.125T 0.0022L 0.0039T	-	-	-	+0.013 +0.0005	-0.033 -0.0013	0.033L 0.138T 0.0013L 0.0054T
1120.000 44.0945	1250.000 49.2126	-0.125 -0.0049	-0.028 -0.0011	-0.094 -0.0037	0.094L 0.097T 0.0037L 0.0038T	0.000 0.0000	-0.066 -0.0026	0.066L 0.125T 0.0022L 0.0039T	-	-	-	+0.013 +0.0005	-0.033 -0.0013	0.033L 0.138T 0.0013L 0.0054T

NOTE: Tolerance and shaft diameters are shown in the table as variances from nominal bearing bore.

⁽¹⁾Tolerance range is from +0 to value listed.

These charts are guidelines for specifying shaft and housing fits related to particular operating conditions. Please contact your Timken engineer for more information.

j6			k5			k6			m5		
Shaft Diameter		Fit	Shaft Diameter		Fit	Shaft Diameter		Fit	Shaft Diameter		Fit
Max.	Min.		Max.	Min.		Max.	Min.		Max.	Min.	
mm	mm	mm	mm	mm	mm	mm	mm	mm	mm	mm	mm
in.	in.	in.	in.	in.	in.	in.	in.	in.	in.	in.	in.
+0.018	-0.018	0.018L 0.058T 0.0007L 0.0023T	+0.029	+0.046	0.004T 0.069T 0.0002T 0.0027T	-	-	-	+0.046	+0.021	0.021T 0.086T 0.0008T 0.0034T
+0.018	-0.018	0.018L 0.058T 0.0007L 0.0023T	+0.029	+0.004	0.004T 0.069T 0.0002T 0.0027T	-	-	-	+0.046	+0.021	0.021T 0.086T 0.0008T 0.0034T
+0.020	-0.020	0.020L 0.065T 0.0008L 0.0026T	+0.032	+0.005	0.005T 0.077T 0.0002T 0.0031T	-	-	-	+0.050	+0.023	0.023T 0.095T 0.0009T 0.0037T
+0.020	-0.020	0.020L 0.065T 0.0008L 0.0026T	+0.032	+0.005	0.005T 0.077T 0.0002T 0.0031T	-	-	-	+0.050	+0.023	0.023T 0.095T 0.0009T 0.0037T
+0.022	-0.022	0.022L 0.072T 0.0009L 0.0029T	+0.030	0.000	0.00T 0.080T 0.0000T 0.0032T	-	-	-	+0.056	+0.026	0.026T 0.106T 0.0010T 0.0042T
+0.022	-0.022	0.022L 0.072T 0.0009L 0.0029T	+0.030	0.000	0.00T 0.080T 0.0000T 0.0032T	-	-	-	+0.056	+0.026	0.026T 0.106T 0.0010T 0.0042T
+0.025	-0.025	0.025L 0.100T 0.0010L 0.0040T	+0.035	0.000	0.000T 0.110T 0.0000T 0.0044T	-	-	-	+0.065	+0.030	0.030T 0.140T 0.0012T 0.0056T
+0.025	-0.025	0.025L 0.100T 0.0010L 0.0040T	+0.035	0.000	0.000T 0.110T 0.0000T 0.0044T	-	-	-	+0.065	+0.030	0.030T 0.140T 0.0012T 0.0056T
+0.025	-0.025	0.028L 0.128T 0.0011L 0.0050L	+0.040	0.000	0.000T 0.140T 0.0000T 0.0055T	-	-	-	+0.074	+0.030	0.034T 0.174T 0.0012T 0.0056T
+0.028	-0.028	0.028L 0.128T 0.0011L 0.0050T	+0.040	0.000	0.000T 0.140T 0.0000T 0.0055T	-	-	-	+0.074	+0.034	0.034T 0.174T 0.0013T 0.0068T
+0.028	-0.028	0.033L 0.158T 0.0013L 0.0062T	+0.046	0.000	0.000T 0.171T 0.0000T 0.0067T	-	-	-	+0.086	+0.040	0.040T 0.211T 0.0016T 0.0083T
+0.033	-0.033	0.033L 0.158T 0.0013L 0.0062T	+0.046	0.000	0.000T 0.171T 0.0000T 0.0067T	-	-	-	+0.086	+0.040	0.040T 0.211T 0.0016T 0.0083T

SHAFT AND HOUSING FITS

These charts are guidelines for specifying shaft and housing fits related to particular operating conditions. Please contact your Timken engineer for more information.

TABLE 10. RADIAL BALL, SPHERICAL ROLLER AND CYLINDRICAL ROLLER BEARING SHAFT TOLERANCES

Bearing Bore			m6			n6			p6			r6			r7		
Nominal (Max.)		Tolerance ⁽¹⁾	Shaft Diameter			Shaft Diameter			Shaft Diameter			Shaft Diameter			Shaft Diameter		
Over	Incl.		Max.	Min.	Fit	Max.	Min.	Fit	Max.	Min.	Fit	Max.	Min.	Fit	Max.	Min.	Fit
mm	mm	mm	mm	mm	mm	mm	mm	mm	mm	mm	mm	mm	mm	mm	mm	mm	mm
in.	in.	in.	in.	in.	in.	in.	in.	in.	in.	in.	in.	in.	in.	in.	in.	in.	in.
3.000	6.000	-0.008	-	-	-	-	-	-	-	-	-	-	-	-	-	-	-
0.1181	0.2362	-0.0003															
6.000	10.000	-0.008	-	-	-	-	-	-	-	-	-	-	-	-	-	-	-
0.2362	0.3937	-0.0003															
10.000	18.000	-0.008	-	-	-	-	-	-	-	-	-	-	-	-	-	-	-
0.3937	0.7087	-0.0003															
18.000	30.000	-0.010	-	-	-	-	-	-	-	-	-	-	-	-	-	-	-
0.7087	1.1811	-0.0004															
30.000	50.000	-0.012	+0.025	+0.009	0.009T	-	-	-	-	-	-	-	-	-	-	-	-
1.1811	1.9685	-0.0005	+0.0010	+0.0004	0.037T												
					0.0004T												
					0.0145T												
50.000	80.000	-0.015	+0.030	+0.011	0.011T	+0.039	+0.020	0.020T	-	-	-	-	-	-	-	-	-
1.9685	3.1496	-0.0006	+0.0012	+0.0004	0.045T	+0.0015	+0.0008	0.054T									
					0.0004T			0.0008T									
					0.0018T			0.0021T									
80.000	120.000	-0.020	+0.035	+0.013	0.013T	+0.045	+0.023	0.023T	+0.059	+0.037	0.037T	-	-	-	-	-	-
3.1496	4.7244	-0.0008	+0.0014	+0.0005	0.055T	+0.0018	+0.0009	0.065T	+0.0023	+0.0015	0.079T						
					0.0005T			0.0009T			0.0015T						
					0.0022T			0.0026T			0.0031T						
120.000	180.000	-0.025	+0.040	+0.015	0.015T	+0.052	+0.027	0.027T	+0.068	+0.043	0.043T	+0.090	+0.065	0.065T	-	-	-
4.7244	7.0866	-0.0010	+0.0016	+0.0006	0.065T	+0.0020	+0.0011	0.077T	+0.0027	+0.0017	0.093T	+0.0035	+0.0026	0.115T			
					0.0006T			0.0011T			0.0017T			0.0026T			
					0.0026T			0.0030T			0.0037T			0.0045T			
180.000	200.000	-0.030	+0.046	+0.017	0.017T	+0.060	+0.031	0.031L	+0.079	+0.050	0.050T	+0.106	+0.077	0.077T	-	-	-
7.0866	7.8740	-0.0012	+0.0018	+0.0007	0.076T	+0.0024	+0.0012	0.090T	+0.0031	+0.0020	0.109T	+0.0042	+0.0030	0.136T			
					0.0007T			0.0012L			0.0020T			0.0030T			
					0.0030T			0.0036T			0.0043T			0.0054T			
200.000	225.000	-0.030	+0.046	+0.017	0.017T	+0.060	+0.031	0.031L	+0.079	+0.050	0.050T	+0.109	+0.080	0.080T	+0.126	+0.080	0.080T
7.8740	8.8583	-0.0012	+0.0018	+0.0007	0.076T	+0.0024	+0.0012	0.090T	+0.0031	+0.0020	0.109T	+0.0043	+0.0031	0.139T	+0.0050	+0.0031	0.156T
					0.0007T			0.0012L			0.0020T			0.0031T			0.0031T
					0.0030T			0.0036T			0.0043T			0.0055T			0.0062T
225.000	250.000	-0.030	+0.046	+0.017	0.017T	+0.060	+0.031	0.031L	+0.079	+0.050	0.050T	+0.113	+0.084	0.084T	+0.130	+0.084	0.084T
8.8583	9.8425	-0.0012	+0.0018	+0.0007	0.076T	+0.0024	+0.0012	0.090T	+0.0031	+0.0020	0.109T	+0.0044	+0.0033	0.143T	+0.0051	+0.0033	0.160T
					0.0007T			0.0012L			0.0020T			0.0033T			0.0033T
					0.0030T			0.0036T			0.0043T			0.0056T			0.0063T
250.000	280.000	-0.035	+0.052	+0.020	0.020T	+0.066	+0.034	0.034T	+0.088	+0.056	0.056T	+0.126	+0.094	0.094T	+0.146	+0.094	0.094T
9.8425	11.0236	-0.0014	+0.0020	+0.0008	0.087T	+0.0026	+0.0013	0.101T	+0.0035	+0.0022	0.123T	+0.0050	+0.0037	0.161T	+0.0057	+0.0037	0.181T
					0.0008T			0.0013T			0.0022T			0.0037T			0.0037T
					0.0034T			0.0040T			0.0049T			0.0064T			0.0071T
280.000	315.000	-0.035	+0.052	+0.020	0.020T	+0.066	+0.034	0.034T	+0.088	+0.056	0.056T	+0.130	+0.098	0.098T	+0.150	+0.098	0.098T
11.0236	12.4016	-0.0014	+0.0020	+0.0008	0.087T	+0.0026	+0.0013	0.101T	+0.0035	+0.0022	0.123T	+0.0051	+0.0039	0.165T	+0.0059	+0.0039	0.185T
					0.0008T			0.0013T			0.0022T			0.0039T			0.0039T
					0.0034T			0.0040T			0.0049T			0.0065T			0.0073T

NOTE: Tolerance and shaft diameters are shown in the table as variances from nominal bearing bore.

⁽¹⁾Tolerance range is from +0 to value listed.

Continued on next page.

These charts are guidelines for specifying shaft and housing fits related to particular operating conditions. Please contact your Timken engineer for more information.

Table 10 continued.

Bearing Bore			m6			n6			p6			r6			r7		
Nominal (Max.)		Tolerance ⁽¹⁾	Shaft Diameter		Fit	Shaft Diameter		Fit	Shaft Diameter		Fit	Shaft Diameter		Fit	Shaft Diameter		Fit
Over	Incl.		Max.	Min.		Max.	Min.		Max.	Min.		Max.	Min.		Max.	Min.	
mm	mm	mm	mm	mm	mm	mm	mm	mm	mm	mm	mm	mm	mm	mm	mm	mm	mm
in.	in.	in.	in.	in.	in.	in.	in.	in.	in.	in.	in.	in.	in.	in.	in.	in.	in.
315.000	355.000	-0.040	+0.057	+0.021	0.097T	+0.073	+0.037	0.113T	+0.098	+0.062	0.138T	+0.144	+0.108	0.184T	+0.165	+0.108	0.205T
12.4016	13.9764	-0.0016	+0.0022	+0.0008	0.0008T	+0.0029	+0.0015	0.0015T	+0.0039	+0.0024	0.0024T	+0.0057	+0.0043	0.0043T	+0.0065	+0.0043	0.0043T
					0.0038T			0.0045T			0.0055T			0.0073T			0.0081T
355.000	400.000	-0.040	-	-	-	+0.073	+0.037	0.113T	+0.098	+0.062	0.138T	+0.150	+0.114	0.190T	+0.171	+0.114	0.211T
13.9764	15.7480	-0.0016				+0.0029	+0.0015	0.0015T	+0.0039	+0.0024	0.0024T	+0.0059	+0.0045	0.0045T	+0.0067	+0.0045	0.0045T
								0.0045T			0.0055T			0.0075T			0.0083T
400.000	450.000	-0.045	-	-	-	+0.080	+0.040	0.125T	+0.108	+0.068	0.153T	+0.166	+0.126	0.211T	+0.189	+0.126	0.234T
15.7480	17.7165	-0.0018				+0.0031	+0.0016	0.0016T	+0.0043	+0.0027	0.0027T	+0.0065	+0.0050	0.0050T	+0.0074	+0.0050	0.0050T
								0.0049T			0.0061T			0.0083T			0.0092T
450.000	500.000	-0.045	-	-	-	+0.080	+0.040	0.125T	+0.108	+0.068	0.153T	+0.172	+0.132	0.217T	+0.195	+0.132	0.240T
17.7165	19.6850	-0.0018				+0.0031	+0.0016	0.0016T	+0.0043	+0.0027	0.0027T	+0.0068	+0.0052	0.0052T	+0.0077	+0.0052	0.0052T
								0.0049T			0.0061T			0.0086T			0.0095T
500.000	560.000	-0.050	-	-	-	-	-	-	+0.122	+0.078	0.172T	+0.194	+0.150	0.244T	+0.220	+0.150	0.270T
19.6850	22.0472	-0.0020							+0.0048	+0.0031	0.0031T	+0.0076	+0.0059	0.0059T	+0.0087	+0.0059	0.0059T
											0.0068T			0.0096T			0.0107T
560.000	630.000	-0.050	-	-	-	-	-	-	+0.122	+0.078	0.172T	+0.199	+0.155	0.249T	+0.225	+0.155	0.275T
22.0472	24.8032	-0.0020							+0.0048	+0.0031	0.0031T	+0.0078	+0.0061	0.0061T	+0.0089	+0.0061	0.0061T
											0.0068T			0.0098T			0.0109T
630.000	710.000	-0.075	-	-	-	-	-	-	+0.138	+0.088	0.213T	+0.225	+0.175	0.300T	+0.255	+0.175	0.330T
24.8032	27.9528	-0.0030							+0.0054	+0.0035	0.0035T	+0.0089	+0.0069	0.0069T	+0.0100	+0.0069	0.0069T
											0.0084T			0.0119T			0.0130T
710.000	800.000	-0.075	-	-	-	-	-	-	+0.138	+0.088	0.213T	+0.235	+0.185	0.310T	+0.265	+0.185	0.340T
27.9528	31.4961	-0.0030							+0.0054	+0.0035	0.0035T	+0.0093	+0.0073	0.0073T	+0.0104	+0.0073	0.0073T
											0.0084T			0.0123T			0.0134T
800.000	900.000	-0.100	-	-	-	-	-	-	+0.156	+0.100	0.256T	+0.266	+0.210	0.366T	+0.300	+0.210	0.400T
31.4961	35.4331	-0.0039							+0.0061	+0.0039	0.0039T	+0.0105	+0.0083	0.0083T	+0.0118	+0.0083	0.0083T
											0.0100T			0.0144T			0.0157T
900.000	1000.000	-0.100	-	-	-	-	-	-	+0.156	+0.100	0.256T	+0.276	+0.220	0.366T	+0.0310	+0.220	0.410T
35.4331	39.3701	-0.0039							+0.0061	+0.0039	0.0039T	+0.0109	+0.0087	0.0087T	+0.0122	+0.0087	0.0087T
											0.0100T			0.0148T			0.0161T
1000.000	1120.000	-0.125	-	-	-	-	-	-	+0.186	+0.120	0.311T	+0.316	+0.250	0.441T	+0.355	+0.250	0.480T
39.3701	44.0945	-0.0049							+0.0073	+0.0047	0.0047T	+0.0124	+0.0098	0.0098T	+0.0140	+0.0098	0.0098T
											0.0122T			0.0173T			0.0189T
1120.000	1250.000	-0.125	-	-	-	-	-	-	+0.186	+0.120	0.311T	+0.326	+0.260	0.451T	+0.365	+0.260	0.490T
44.0945	49.2126	-0.0049							+0.0073	+0.0047	0.0047T	+0.0128	+0.0102	0.0102T	+0.0144	+0.0102	0.0102T
											0.0122T			0.0177T			0.0193T

These charts are guidelines for specifying shaft and housing fits related to particular operating conditions. Please contact your Timken engineer for more information.

HOUSING TOLERANCES

TABLE 11. RADIAL BALL, SPHERICAL ROLLER AND CYLINDRICAL ROLLER BEARING HOUSING TOLERANCES

Bearing O.D.			F7			G7			H6			H7		
Nominal (Max.) Over Incl.		Tolerance ⁽¹⁾	Housing Bore		Fit	Housing Bore		Fit	Housing Bore		Fit	Housing Bore		Fit
mm	mm	mm	mm	mm	mm	mm	mm	mm	mm	mm	mm	mm	mm	mm
in.	in.	in.	in.	in.	in.	in.	in.	in.	in.	in.	in.	in.	in.	in.
10.000	18.000	-0.008	+0.034	+0.016	0.016L	+0.024	+0.002	0.006L	+0.011	0.000	0.000L	+0.018	0.000	0.000L
0.3937	0.7087	-0.0003	+0.0013	+0.0006	0.0006L	+0.0009	+0.0002	0.0002L	+0.0004	0.0000	0.0000L	+0.0007	0.0000	0.0000L
					0.016L			0.0012L			0.0007L			0.010L
					0.042L			0.032L			0.019L			0.026L
					0.006L			0.002L			0.000L			0.000L
					0.016L			0.0012L			0.0007L			0.010L
18.000	30.000	-0.009	+0.041	+0.020	0.020L	+0.028	+0.007	0.007L	+0.013	0.000	0.000L	+0.021	0.000	0.000L
0.7087	1.1811	-0.0035	+0.0016	+0.0008	0.0008L	+0.0011	+0.0003	0.0003L	+0.0005	0.0000	0.0000L	+0.0008	0.0000	0.0000L
					0.020L			0.037L			0.022L			0.030L
					0.008L			0.003L			0.000L			0.000L
					0.0195L			0.00145L			0.00085L			0.00125L
					0.050L			0.007L			0.000L			0.000L
					0.008L			0.003L			0.000L			0.000L
					0.0195L			0.00145L			0.00085L			0.00125L
30.000	50.000	-0.011	+0.050	+0.025	0.025L	+0.034	+0.009	0.009L	+0.016	0.000	0.000L	+0.025	0.000	0.000L
1.1811	1.9685	-0.00045	+0.0020	+0.0010	0.0010L	+0.0013	+0.0004	0.0004L	+0.0006	0.0000	0.0000L	+0.0010	0.0000	0.0000L
					0.061L			0.045L			0.027L			0.036L
					0.0010L			0.0004L			0.000L			0.000L
					0.00245L			0.00175L			0.0105L			0.00145L
					0.025L			0.009L			0.000L			0.000L
					0.0010L			0.0004L			0.000L			0.000L
					0.00245L			0.00175L			0.0105L			0.00145L
50.000	80.000	-0.013	+0.060	+0.030	0.030L	+0.040	+0.010	0.010L	+0.019	0.000	0.000L	+0.030	0.000	0.000L
1.9685	3.1496	-0.0005	+0.0024	+0.0012	0.0012L	+0.0016	+0.0004	0.0004L	+0.0007	0.0000	0.0000L	+0.0012	0.0000	0.0000L
					0.073L			0.053L			0.032L			0.059L
					0.0012L			0.0004L			0.000L			0.000L
					0.0029L			0.0021L			0.012L			0.017L
					0.030L			0.010L			0.000L			0.000L
					0.0012L			0.0004L			0.000L			0.000L
					0.0029L			0.0021L			0.012L			0.017L
80.000	120.000	-0.015	+0.071	+0.036	0.036L	+0.047	+0.012	0.012L	+0.022	0.000	0.000L	+0.035	0.000	0.000L
3.1496	4.7244	-0.0006	+0.0028	+0.0014	0.0014L	+0.0019	+0.0005	0.0005L	+0.0009	0.0000	0.0000L	+0.0014	0.0000	0.0000L
					0.086L			0.062L			0.037L			0.050L
					0.0014L			0.0005L			0.000L			0.000L
					0.0034L			0.0025L			0.015L			0.0020L
					0.036L			0.012L			0.000L			0.000L
					0.0014L			0.0005L			0.000L			0.000L
					0.0034L			0.0025L			0.015L			0.0020L
120.000	150.000	-0.018	+0.083	+0.043	0.043L	+0.054	+0.014	0.014L	+0.025	0.000	0.000L	+0.040	0.000	0.000L
4.7244	5.9055	-0.0007	+0.0033	+0.0017	0.0017L	+0.0021	+0.0006	0.0006L	+0.0010	0.0000	0.0000L	+0.0016	0.0000	0.0000L
					0.101L			0.072L			0.043L			0.058L
					0.0017L			0.0006L			0.000L			0.000L
					0.0040L			0.0028L			0.017L			0.0023L
					0.043L			0.014L			0.000L			0.000L
					0.0017L			0.0006L			0.000L			0.000L
					0.0043L			0.0031L			0.020L			0.0026L
					0.108L			0.079L			0.050L			0.065L
					0.0017L			0.0006L			0.000L			0.000L
					0.0043L			0.0031L			0.020L			0.0026L
150.000	180.000	-0.025	+0.083	+0.043	0.043L	+0.054	+0.014	0.014L	+0.025	0.000	0.000L	+0.040	0.000	0.000L
5.9055	7.0866	-0.0010	+0.0033	+0.0017	0.0017L	+0.0021	+0.0006	0.0006L	+0.0010	0.0000	0.0000L	+0.0016	0.0000	0.0000L
					0.108L			0.079L			0.050L			0.065L
					0.0017L			0.0006L			0.000L			0.000L
					0.0043L			0.0031L			0.020L			0.0026L
					0.050L			0.015L			0.000L			0.000L
					0.0017L			0.0006L			0.000L			0.000L
					0.0043L			0.0031L			0.020L			0.0026L
180.000	250.000	-0.030	+0.096	+0.050	0.050L	+0.061	+0.015	0.015L	+0.029	0.000	0.000L	+0.046	0.000	0.000L
7.0866	9.8425	-0.0012	+0.0038	+0.0020	0.0020L	+0.0024	+0.0006	0.0006L	+0.0011	0.0000	0.0000L	+0.0018	0.0000	0.0000L
					0.126L			0.091L			0.059L			0.076L
					0.0020L			0.0006L			0.000L			0.000L
					0.0050L			0.0036L			0.023L			0.0030L
					0.050L			0.015L			0.000L			0.000L
					0.0020L			0.0006L			0.000L			0.000L
					0.0050L			0.0036L			0.023L			0.0030L
250.000	315.000	-0.035	+0.108	+0.056	0.056L	+0.069	+0.017	0.017L	+0.032	0.000	0.000L	+0.052	0.000	0.000L
9.8425	12.4016	-0.0014	+0.0043	+0.0022	0.0022L	+0.0027	+0.0007	0.0007L	+0.0013	0.0000	0.0000L	+0.0020	0.0000	0.0000L
					0.143L			0.104L			0.067L			0.087L
					0.0022L			0.0007L			0.000L			0.000L
					0.0057L			0.0041L			0.027L			0.0034L
					0.056L			0.017L			0.000L			0.000L
					0.0022L			0.0007L			0.000L			0.000L
					0.0057L			0.0041L			0.027L			0.0034L
315.000	400.000	-0.040	+0.119	+0.062	0.062L	+0.075	+0.018	0.018L	+0.089	0.000	0.000L	+0.057	0.000	0.000L
12.4016	15.7480	-0.0016	+0.0047	+0.0024	0.0024L	+0.0030	+0.0007	0.0007L	+0.0014	0.0000	0.0000L	+0.0022	0.0000	0.0000L
					0.159L			0.115L			0.129L			0.097L
					0.0024L			0.0007L			0.000L			0.000L
					0.0063L			0.0046L			0.030L			0.0038L
					0.062L			0.018L			0.000L			0.000L
					0.0024L			0.0007L			0.000L			0.000L
					0.0063L			0.0046L			0.030L			0.0038L
400.000	500.000	-0.045	+0.131	+0.068	0.068L	+0.083	+0.020	0.020L	+0.097	0.000	0.000L	+0.063	0.000	0.000L
15.7480	19.6850	-0.0018	+0.0052	+0.0027	0.0027L	+0.0033	+0.0008	0.0008L	+0.0016	0.0000	0.0000L	+0.0025	0.0000	0.0000L
					0.176L			0.128L			0.142L			0.108L
					0.0027L			0.0008L			0.000L			0.000L
					0.0070L			0.0051L			0.0034L			0.0043L
					0.068L			0.020L			0.000L			0.000L
					0.0027L			0.0008L			0.000L			0.000L
					0.0070L			0.0051L			0.0034L			0.0043L
500.000	630.000	-0.050	+0.146	+0.076	0.076L	+0.092	+0.022</							

These charts are guidelines for specifying shaft and housing fits related to particular operating conditions. Please contact your Timken engineer for more information.

H8			J6			J7			K6			K7		
Housing Bore		Fit	Housing Bore		Fit	Housing Bore		Fit	Housing Bore		Fit	Housing Bore		Fit
Max.	Min.		Max.	Min.		Max.	Min.		Max.	Min.		Max.	Min.	
mm	mm	mm	mm	mm	mm	mm	mm	mm	mm	mm	mm	mm	mm	mm
in.	in.	in.	in.	in.	in.	in.	in.	in.	in.	in.	in.	in.	in.	in.
+0.027	0.000	0.000L 0.035L	+0.006	-0.005	0.005T 0.014L	+0.10	-0.008	0.018L	+0.002	-0.009	0.010L	+0.006	-0.012	0.012T 0.014L
+0.011	0.0000	0.0000L 0.0014L	+0.0002	-0.0002	0.0002T 0.0005L	+0.004	-0.0003	0.0003T 0.0007L	+0.0001	-0.0004	0.0004T 0.0004L	+0.0002	-0.0005	0.0005T 0.0005L
+0.033	0.000	0.000L 0.030L	+0.008	-0.005	0.005T 0.017L	+0.012	-0.009	0.021L	+0.002	-0.011	0.011L	+0.006	-0.015	0.015T 0.015L
+0.013	0.0000	0.0000L 0.00165L	+0.0003	-0.0002	0.0002T 0.00065L	+0.0005	-0.0004	0.0004T 0.00085L	+0.0001	-0.0004	0.0004T 0.00045L	+0.0002	-0.0006	0.0006T 0.00055L
+0.039	0.000	0.000L 0.050L	+0.010	-0.006	0.006T 0.021L	+0.014	-0.011	0.011T 0.025L	+0.003	-0.014	0.013T 0.014L	+0.007	-0.018	0.018T 0.018L
+0.015	0.0000	0.0000L 0.00195L	+0.0002	-0.0002	0.0002T 0.00085L	+0.0006	-0.0004	0.0004T 0.00105L	+0.0001	-0.0005	0.0005T 0.00055L	+0.0003	-0.0007	0.0007T 0.00065L
+0.046	0.000	0.000L 0.059L	+0.013	-0.006	0.006T 0.026L	+0.018	-0.012	0.012T 0.031L	+0.004	-0.015	0.015T 0.017L	+0.009	-0.021	0.021T 0.022L
+0.018	0.0000	0.0000L 0.0023L	+0.0005	-0.0002	0.0002T 0.0010L	+0.0007	-0.0005	0.0005T 0.0012L	+0.0002	-0.0006	0.0006T 0.0007L	+0.0004	-0.0008	0.0008T 0.0009L
+0.054	0.000	0.000L 0.069L	+0.016	-0.006	0.006T 0.031L	+0.022	-0.013	0.013T 0.037L	+0.004	-0.018	0.018T 0.019L	+0.010	-0.025	0.025T 0.025L
+0.021	0.0000	0.0000L 0.0027L	+0.0006	-0.0002	0.0002T 0.0012L	+0.0009	-0.0005	0.0005T 0.0015L	+0.0002	-0.0007	0.0007T 0.0008L	+0.0004	-0.0010	0.0010T 0.0010L
+0.063	0.000	0.000L 0.081L	+0.018	-0.007	0.007T 0.036L	+0.026	-0.014	0.014T 0.044L	+0.004	-0.021	0.021T 0.022L	+0.012	-0.028	0.028T 0.030L
+0.025	0.0000	0.0000L 0.0032L	+0.0007	-0.0003	0.0003T 0.0014L	+0.0010	-0.0006	0.0006T 0.0017L	+0.0002	-0.0008	0.0008T 0.0009L	+0.0005	-0.0011	0.0011T 0.0012L
+0.063	0.000	0.000L 0.088L	+0.018	-0.007	0.007T 0.043L	+0.026	-0.014	0.014T 0.051L	+0.004	-0.021	0.021T 0.029L	+0.012	-0.033	0.028T 0.037L
+0.025	0.0000	0.0000L 0.0035L	+0.0007	-0.0003	0.0003T 0.0017L	+0.0010	-0.0006	0.0006T 0.0020L	+0.0002	-0.0008	0.0008T 0.0012L	+0.0005	-0.0028	0.0011T 0.0015L
+0.072	0.000	0.000L 0.102L	+0.022	-0.007	0.007T 0.052L	+0.030	-0.016	0.016T 0.060L	+0.005	-0.024	0.024T 0.035L	+0.013	-0.011	0.033T 0.043L
+0.028	0.0000	0.0000L 0.0040L	+0.0007	-0.0003	0.0003T 0.0021L	+0.0012	-0.0006	0.0006T 0.0024L	+0.0002	-0.0009	0.0009T 0.0014L	+0.0005	-0.0013	0.0013T 0.0017L
+0.081	0.000	0.000L 0.116L	+0.025	-0.007	0.007T 0.060L	+0.036	-0.016	0.016T 0.071L	+0.005	-0.027	0.027T 0.040L	+0.016	-0.036	0.036T 0.051L
+0.032	0.0000	0.0000L 0.0046L	+0.0010	-0.0003	0.0003T 0.0024L	+0.0014	-0.0006	0.0006T 0.0028L	+0.0002	-0.0011	0.0011T 0.0016L	+0.0006	-0.0014	0.0014T 0.0020L
+0.036	0.000	0.000L 0.076L	+0.029	-0.007	0.007T 0.069L	+0.039	-0.018	0.018T 0.079L	+0.007	-0.029	0.029T 0.047L	+0.017	-0.040	0.040T 0.057L
+0.035	0.0000	0.0000L 0.0051L	+0.0011	-0.0003	0.0003T 0.0027L	+0.0015	-0.0007	0.0007T 0.0031L	+0.0003	-0.0011	0.0011T 0.0019L	+0.0007	-0.0016	0.0016T 0.0023L
+0.040	0.000	0.000L 0.085	+0.033	-0.007	0.007T 0.078L	+0.043	-0.020	0.020T 0.088L	+0.008	-0.032	0.032T 0.053L	+0.018	-0.045	0.045T 0.063L
+0.038	0.0000	0.0000L 0.0056L	+0.0013	-0.0003	0.0003T 0.0031L	+0.0017	-0.0008	0.0008T 0.0035L	+0.0003	-0.0013	0.0013T 0.0021L	+0.0007	-0.0018	0.0018T 0.0025L
+0.044	0.000	0.000L 0.094L	+0.037	-0.007	0.022T 0.098L	+0.048	-0.022	0.022T 0.098L	0.000	-0.044	0.044T 0.050L	0.000	-0.070	0.070T 0.050L
+0.043	0.0000	0.0000L 0.0063L	+0.0015	-0.0003	0.0003T 0.0035L	+0.0019	-0.0009	0.0009T 0.0039L	0.0000	-0.0017	0.0017T 0.0020L	0.0000	-0.0028	0.0028T 0.0020L

Continued on next page.

SHAFT AND HOUSING FITS

These charts are guidelines for specifying shaft and housing fits related to particular operating conditions. Please contact your Timken engineer for more information.

Table 11 continued.

Bearing O.D.			F7			G7			H6			H7		
Nominal (Max.)		Tolerance ⁽¹⁾	Housing Bore		Fit	Housing Bore		Fit	Housing Bore		Fit	Housing Bore		Fit
Over	Incl.		Max.	Min.		Max.	Min.		Max.	Min.		Max.	Min.	
mm	mm	mm	mm	mm	mm	mm	mm	mm	mm	mm	mm	mm	mm	mm
in.	in.	in.	in.	in.	in.	in.	in.	in.	in.	in.	in.	in.	in.	in.
630.000	800.000	-0.075	+0.160	+0.080	0.080L 0.235L	+0.104	+0.024	0.024L 0.179L	+0.125	0.000	0.000L 0.200L	+0.080	0.000	0.000L 0.155L
24.8032	31.4961	-0.0030	+0.0063	+0.0031	0.0031L 0.0093L	+0.0041	+0.0009	0.0009L 0.0071L	+0.0020	0.0000	0.0000L 0.0030L	+0.0031	0.0000	0.0000L 0.0061L
800.000	1000.000	-0.100	+0.179	+0.086	0.086L 0.276L	+0.116	+0.026	0.026L 0.216L	+0.140	0.000	0.000L 0.240L	+0.090	0.000	0.000L 0.190L
31.4961	39.3701	-0.0039	+0.0063	+0.0034	0.0034L 0.0108L	+0.0046	+0.0010	0.0010L 0.0085L	+0.0022	0.0000	0.0000L 0.0061L	+0.0035	0.0000	0.0000L 0.0074L
1000.000	1250.000	-0.125	+0.203	+0.098	0.098L 0.328L	+0.133	+0.028	0.028L 0.258L	+0.165	0.000	0.000L 0.290L	+0.105	0.000	0.000L 0.230L
39.3701	49.2126	-0.0049	+0.0080	+0.0039	0.0039L 0.0129L	+0.0052	+0.0011	0.0011L 0.0101L	+0.0026	0.0000	0.0000L 0.0075L	+0.0041	0.0000	0.0000L 0.0090L
1250.000	1600.000	-0.160	+0.155	+0.030	0.110L 0.395L	+0.155	+0.030	0.030L 0.315L	+0.195	0.000	0.000L 0.355L	+0.125	0.000	0.000L 0.355L
49.2126	62.9921	-0.0063	+0.0093	+0.0043	0.0043L 0.0156L	+0.0061	+0.0012	0.0012L 0.0124L	+0.0031	0.0000	0.0000L 0.0094L	+0.0049	0.0000	0.0000L 0.0112L
1600.000	2000.000	-0.200	+0.270	+0.120	0.120L 0.470L	+0.182	+0.032	0.032L 0.382L	+0.230	0.000	0.000L 0.430L	+0.150	0.000	0.000L 0.350L
62.9921	78.7402	-0.0079	+0.0106	+0.0047	0.0047L 0.0185L	+0.0072	+0.0013	0.0013L 0.0151L	+0.0036	0.0000	0.0000L 0.0115L	+0.0059	0.0000	0.0000L 0.0138L
2000.000	2500.000	-0.250	+0.305	+0.0130	0.130L 0.555L	+0.209	+0.034	0.034L 0.459L	+0.280	0.000	0.000L 0.530L	+0.175	0.000	0.000L 0.425L
78.7402	98.4252	-0.0098	0.0120	+0.0051	0.0051L 0.0218L	+0.0082	+0.0013	0.0013L 0.0180L	+0.043	0.0000	0.0000L 0.0141L	+0.0069	0.0000	0.0000L 0.0167L

NOTE: Tolerance and shaft diameters are shown in the table as variances from nominal bearing O.D.

⁽¹⁾Tolerance range is from +0 to value listed.

These charts are guidelines for specifying shaft and housing fits related to particular operating conditions. Please contact your Timken engineer for more information.

H8			J6			J7			K6			K7		
Housing Bore		Fit	Housing Bore		Fit	Housing Bore		Fit	Housing Bore		Fit	Housing Bore		Fit
Max.	Min.		Max.	Min.		Max.	Min.		Max.	Min.		Max.	Min.	
mm	mm	mm	mm	mm	mm	mm	mm	mm	mm	mm	mm	mm	mm	mm
in.	in.	in.	in.	in.	in.	in.	in.	in.	in.	in.	in.	in.	in.	in.
+0.050	0.000	0.000L 0.125L	+0.040	-0.010	0.010T 0.115L	+0.056	-0.024	0.024T 0.131L	0.000	-0.050	0.050T 0.075L	0.000	-0.080	0.080T 0.075L
+0.0049	0.0000	0.0000L 0.0079L	+0.0016	-0.0004	0.0004T 0.0046L	+0.0022	-0.0009	0.0009T 0.0052L	0.0000	-0.0020	0.0020T 0.0030L	0.0000	-0.0031	0.0031T 0.0030L
+0.056	0.000	0.000L 0.156L	+0.046	-0.010	0.010T 0.146L	+0.064	-0.026	0.026T 0.164L	0.000	-0.056	0.056T 0.100L	0.000	-0.090	0.090T 0.100L
+0.0055	0.0000	0.0000L 0.0094L	+0.0018	-0.0004	0.0004T 0.0057L	+0.0025	-0.0010	0.0010T 0.0064L	0.0000	-0.0022	0.0022T 0.0039L	0.0000	-0.0035	0.0035T 0.0039L
+0.066	0.000	0.000L 0.191L	+0.056	-0.010	0.010T 0.181L	+0.077	-0.028	0.028T 0.202L	0.000	-0.066	0.066T 0.125L	0.000	-0.105	0.105T 0.125L
+0.0065	0.0000	0.0000L 0.0114L	+0.0022	-0.0004	0.0004T 0.0071L	+0.0030	-0.0011	0.0011T 0.0079L	0.0000	-0.0026	0.0026T 0.0049L	0.0000	-0.0041	0.0041T 0.0049L
+0.078	0.000	0.000L 0.238L	+0.068	-0.010	0.010T 0.228L	+0.095	-0.030	0.030T 0.255L	0.000	-0.078	0.078T 0.160L	0.000	-0.125	0.125T 0.160L
+0.0077	0.0000	0.0000L 0.0104L	+0.0027	-0.0004	0.0004T 0.0090L	+0.0037	-0.0012	0.0012T 0.0100L	0.0000	-0.0031	0.0031T 0.0063L	0.0000	-0.0049	0.0049T 0.0063L
+0.092	0.000	0.000L 0.292L	+0.082	-0.010	0.010T 0.282L	+0.118	-0.032	0.032T 0.318L	0.000	-0.092	0.092T 0.200L	0.000	-0.150	0.150T 0.200L
+0.0091	0.0000	0.0000L 0.0170L	+0.0032	-0.0004	0.0004T 0.0111L	+0.0046	-0.0013	0.0013T 0.0125L	0.0000	-0.0036	0.0036T 0.0079L	0.0000	-0.0059	0.0059T 0.0079L
+0.110	0.000	0.000L 0.360L	+0.100	-0.010	0.010T 0.350L	+0.141	-0.034	0.034T 0.391L	0.000	-0.110	0.110T 0.250L	0.000	-0.175	0.175T 0.250L
+0.0110	0.0000	0.0000L 0.0208L	+0.0039	-0.0004	0.0004T 0.0137L	+0.0056	-0.0013	0.0013T 0.0154L	0.0000	-0.0043	0.0043T 0.0098L	0.0000	-0.0069	0.0069T 0.0098L

SHAFT AND HOUSING FITS

These charts are guidelines for specifying shaft and housing fits related to particular operating conditions. Please contact your Timken engineer for more information.

TABLE 12. RADIAL BALL, SPHERICAL ROLLER AND CYLINDRICAL ROLLER BEARING HOUSING TOLERANCES

Bearing O.D.			M6			M7			N6			N7		
Nominal (Max.) Over Incl.		Tolerance ⁽¹⁾	Housing Bore		Fit	Housing Bore		Fit	Housing Bore		Fit	Housing Bore		Fit
mm in.	mm in.	mm in.	mm in.	mm in.	mm in.	mm in.	mm in.	mm in.	mm in.	mm in.	mm in.	mm in.	mm in.	mm in.
10.000 0.3937	18.000 0.7087	-0.008 -0.0003	-0.004 -0.0002	-0.015 -0.0006	0.015T 0.004L 0.006T 0.001L	0.000 0.0000	-0.018 -0.0007	0.018T 0.008L 0.007T 0.003L	-0.009 -0.0004	-0.020 -0.0008	0.020T 0.001T 0.008T 0.001T	-0.005 -0.0002	-0.023 -0.0009	0.023T 0.003L 0.009T 0.001L
18.000 0.7087	30.000 1.1811	-0.009 -0.0035	-0.004 -0.0002	-0.017 -0.0007	0.017T 0.005L 0.007T 0.0015L	0.000 0.0000	-0.021 -0.0008	0.021T 0.009L 0.008T 0.0035L	-0.007 -0.0004	-0.028 -0.0009	0.024T 0.002T 0.009T 0.0005T	-0.007 -0.0003	-0.028 -0.0011	0.028T 0.002L 0.011T 0.0005L
30.000 1.1811	50.000 1.9685	-0.011 -0.0045	-0.004 -0.0002	-0.020 -0.0008	0.020T 0.007L 0.008T 0.0025L	0.000 0.0000	-0.025 -0.0010	0.025T 0.011L 0.010T 0.0045L	-0.012 -0.0005	-0.028 -0.0011	0.028T 0.001T 0.011T 0.0005T	-0.008 -0.0003	-0.033 -0.0013	0.033T 0.003L 0.013T 0.0015L
50.000 1.9685	80.000 3.1496	-0.013 -0.0005	-0.005 -0.0002	-0.024 -0.0009	0.024T 0.008L 0.009T 0.0003L	0.000 0.0000	-0.030 -0.0012	0.030T 0.013L 0.012T 0.0005L	-0.014 -0.0006	-0.033 -0.0013	0.033T 0.001T 0.013T 0.001T	-0.009 -0.0004	-0.039 -0.0015	0.039T 0.004L 0.015T 0.0001L
80.000 3.1496	120.000 4.7244	-0.015 -0.0006	-0.006 -0.0002	-0.028 -0.0011	0.028T 0.009L 0.011T 0.0004L	0.000 0.0000	-0.035 -0.0014	0.035T 0.015L 0.014T 0.0006L	-0.016 -0.0006	-0.038 -0.0015	0.038T 0.001T 0.015T 0.0000T	-0.010 -0.0004	-0.045 -0.0018	0.045T 0.005L 0.018T 0.0002L
120.000 4.7244	150.000 5.9055	-0.018 -0.0007	-0.008 -0.0003	-0.033 -0.0013	0.033T 0.010L 0.013T 0.0004L	0.000 0.0000	-0.040 -0.0016	0.040T 0.018L 0.016T 0.0007L	-0.020 -0.0008	-0.045 -0.0018	0.045T 0.002T 0.018T 0.001T	-0.012 -0.0005	-0.052 -0.0020	0.061T 0.018L 0.020T 0.0002L
150.000 5.9055	180.000 7.0866	-0.025 -0.0010	-0.008 -0.0003	-0.033 -0.0013	0.033T 0.017L 0.013T 0.0007L	0.000 0.0000	-0.040 -0.0016	0.040T 0.025L 0.016T 0.0010L	-0.020 -0.0008	-0.045 -0.0018	0.045T 0.005T 0.018T 0.0002T	-0.012 -0.0005	-0.052 -0.0020	0.052T 0.013L 0.020T 0.0005L
180.000 7.0866	250.000 9.8425	-0.030 -0.0012	-0.008 -0.0003	-0.037 -0.0015	0.037T 0.022L 0.015T 0.0009L	0.000 0.0000	-0.046 -0.0018	0.046T 0.030L 0.018T 0.0012L	-0.022 -0.0009	-0.051 -0.0020	0.051T 0.008T 0.020T 0.0003T	-0.014 -0.0006	-0.060 -0.0024	0.060T 0.016L 0.024T 0.0006L
250.000 9.8425	315.000 12.4016	-0.035 -0.0014	-0.009 -0.0004	-0.041 -0.0016	0.041T 0.026L 0.016T 0.0010L	0.000 0.0000	-0.052 -0.0020	0.052T 0.035L 0.020T 0.0014L	-0.025 -0.0010	-0.057 -0.0022	0.057T 0.010T 0.022T 0.0004T	-0.014 -0.0006	-0.066 -0.0026	0.066T 0.021L 0.025T 0.0008L
315.000 12.4016	400.000 15.7480	-0.040 -0.0016	-0.010 -0.0004	-0.046 -0.0018	0.046T 0.030L 0.018T 0.0012L	0.000 0.0000	-0.057 -0.0022	0.057T 0.040L 0.022T 0.0016L	-0.026 -0.0006	-0.062 -0.0029	0.062T 0.014T 0.024T 0.0006T	-0.016 -0.0006	-0.073 -0.0029	0.073T 0.024L 0.029T 0.0010L
400.000 15.7480	500.000 19.6850	-0.045 -0.0018	-0.010 -0.0004	-0.050 -0.0020	0.050T 0.035L 0.020T 0.0014L	0.000 0.0000	-0.063 -0.0025	0.063T 0.045L 0.025T 0.0018L	-0.027 -0.0011	-0.067 -0.0026	0.067T 0.018T 0.026T 0.0007T	-0.017 -0.0007	-0.080 -0.0031	0.080T 0.028L 0.031T 0.0011L
500.000 19.6850	630.000 24.8032	-0.050 -0.0020	-0.026 -0.0010	-0.070 -0.0028	0.070T 0.024L 0.028T 0.0010L	-0.026 -0.0010	-0.096 -0.0038	0.096T 0.024L 0.038T 0.0010L	-0.044 -0.0017	-0.088 -0.0035	0.088T 0.006T 0.035T 0.0003T	-0.044 -0.0017	-0.114 -0.0045	0.114T 0.006L 0.045T 0.0003L

NOTE: Tolerance and shaft diameters are shown in the table as variances from nominal bearing O.D.

⁽¹⁾Tolerance range is from +0 to value listed.

These charts are guidelines for specifying shaft and housing fits related to particular operating conditions. Please contact your Timken engineer for more information.

P6			P7		
Housing Bore		Fit	Housing Bore		Fit
Max.	Min.		Max.	Min.	
mm in.	mm in.	mm in.	mm in.	mm in.	mm in.
-0.015 -0.0006	-0.026 -0.0010	0.026T 0.007T 0.0010T 0.0003T	-0.011 -0.0004	-0.029 -0.0011	0.029T 0.003T 0.0011T 0.0001T
-0.018 -0.0007	-0.031 -0.0012	0.031T 0.009T 0.0012T 0.00035T	-0.014 -0.0006	-0.035 -0.0014	0.035T 0.005T 0.0014T 0.0025T
-0.021 -0.0008	-0.037 -0.0015	0.037T 0.010T 0.0015T 0.00035T	-0.017 -0.0007	-0.042 -0.0017	0.042T 0.006T 0.0017T 0.0025T
-0.026 -0.0010	-0.045 -0.0018	0.045T 0.013T 0.0018T 0.0005T	-0.021 -0.0008	-0.051 -0.0020	0.051T 0.008T 0.0020T 0.0003T
-0.030 -0.0012	-0.052 -0.0020	0.052T 0.015T 0.0020T 0.0006T	-0.024 -0.0009	-0.059 -0.0023	0.059T 0.009T 0.0023T 0.0003T
-0.036 -0.0014	-0.061 -0.0024	0.061T 0.018T 0.0024T 0.0007T	-0.028 -0.0011	-0.068 -0.0027	0.068T 0.010T 0.0027T 0.0004T
-0.036 -0.0014	-0.061 -0.0024	0.061T 0.011T 0.0024T 0.0004T	-0.028 -0.0011	-0.068 -0.0027	0.068T 0.003T 0.0027T 0.0001T
-0.041 -0.0016	-0.070 -0.0028	0.070T 0.011T 0.0028T 0.0004T	-0.033 -0.0013	-0.079 -0.0031	0.079T 0.003T 0.0031T 0.0001T
-0.047 -0.0019	-0.079 -0.0031	0.079T 0.012T 0.0031T 0.0005T	-0.036 -0.0014	-0.088 -0.0035	0.088T 0.001T 0.0035T 0.0000T
-0.051 -0.0020	-0.087 -0.0034	0.087T 0.011T 0.0034T 0.0004T	-0.041 -0.0016	-0.098 -0.0039	0.098T 0.001T 0.0039T 0.0000T
-0.055 -0.0022	-0.095 -0.0037	0.095T 0.010T 0.0037T 0.0004T	-0.045 -0.0018	-0.108 -0.0043	0.108T 0.000T 0.0043T 0.0000T
-0.078 -0.0031	-0.122 -0.0048	0.122T 0.028T 0.0048T 0.0011T	-0.078 -0.0031	-0.148 -0.0058	0.148T 0.028T 0.0058T 0.0011T

Continued on next page.

SHAFT AND HOUSING FITS

These charts are guidelines for specifying shaft and housing fits related to particular operating conditions. Please contact your Timken engineer for more information.

Table 12 continued.

Bearing O.D.			M6			M7			N6			N7		
Nominal (Max.) Over Incl.		Tolerance ⁽¹⁾	Housing Bore		Fit	Housing Bore		Fit	Housing Bore		Fit	Housing Bore		Fit
mm in.	mm in.	mm in.	mm in.	mm in.	mm in.	mm in.	mm in.	mm in.	mm in.	mm in.	mm in.	mm in.	mm in.	mm in.
630.000 24.8032	800.000 31.4961	-0.075 -0.0030	-0.030 -0.0012	-0.080 -0.0031	0.080T 0.045L 0.0031T 0.0018L	-0.030 -0.0012	-0.110 -0.0043	0.110T 0.045L 0.0043T 0.0018L	-0.050 -0.0020	-0.100 -0.0039	0.100T 0.025T 0.0039T 0.0010T	-0.050 -0.0020	-0.130 -0.0051	0.130T 0.025L 0.0051T 0.0010L
800.000 31.4961	1000.000 39.3701	-0.100 -0.0039	-0.034 -0.0013	-0.090 -0.0035	0.090T 0.066L 0.0035T 0.0026L	-0.034 -0.0013	-0.124 -0.0049	0.124T 0.066L 0.0049T 0.0026L	-0.056 -0.0022	-0.112 -0.0044	0.112T 0.044T 0.0044T 0.0017T	-0.056 -0.0022	-0.146 -0.0057	0.146T 0.044L 0.0057T 0.0017L
1000.000 39.3701	1250.000 49.2126	-0.125 -0.0049	-0.040 -0.0016	-0.106 -0.0042	0.106T 0.085L 0.0042T 0.0033L	-0.040 -0.0016	-0.145 -0.0057	0.145T 0.085L 0.0057T 0.0033L	-0.066 -0.0026	-0.132 -0.0052	0.132T 0.059T 0.0052T 0.0023T	-0.066 -0.0026	-0.171 -0.0067	0.171T 0.059L 0.0067T 0.0023L
1250.000 49.2126	1600.000 62.9921	-0.160 -0.0063	-0.048 -0.0019	-0.126 -0.0050	0.126T 0.112L 0.0050T 0.0044L	-0.048 -0.0019	-0.173 -0.0068	0.173T 0.112L 0.0068T 0.0044L	-0.078 -0.0031	-0.156 -0.0061	0.156T 0.082T 0.0061T 0.0032T	-0.078 -0.0031	-0.203 -0.0080	0.203T 0.082L 0.0080T 0.0023L
1600.000 62.9921	2000.000 78.7402	-0.200 -0.0079	-0.058 -0.0023	-0.150 -0.0059	0.150T 0.142L 0.0059T 0.0056L	-0.058 -0.0023	-0.208 -0.0082	0.208T 0.142L 0.0082T 0.0056L	-0.092 -0.0036	-0.184 -0.0072	0.184T 0.108T 0.0072T 0.0043T	-0.092 -0.0036	-0.242 -0.0095	0.242T 0.108L 0.0095T 0.0043L
2000.000 78.7402	2500.000 98.4252	-0.250 -0.0098	-0.068 -0.0027	-0.178 -0.0070	0.178T 0.182L 0.0070T 0.0071L	-0.068 -0.0027	-0.243 -0.0096	0.243T 0.182L 0.0096T 0.0071L	-0.110 -0.0043	-0.220 -0.0087	0.285T 0.140T 0.112T 0.055T	-0.110 -0.0043	-0.285 -0.0112	0.285T 0.140L 0.0112T 0.0055L

NOTE: Tolerance and shaft diameters are shown in the table as variances from nominal bearing O.D.

⁽¹⁾Tolerance range is from +0 to value listed.

These charts are guidelines for specifying shaft and housing fits related to particular operating conditions. Please contact your Timken engineer for more information.

P6			P7		
Housing Bore		Fit	Housing Bore		Fit
Max.	Min.		Max.	Min.	
mm in.	mm in.	mm in.	mm in.	mm in.	mm in.
-0.088 -0.0035	-0.138 -0.0054	0.138T 0.013T 0.0054T 0.0005T	-0.088 -0.0035	-0.168 -0.0066	0.168T 0.013T 0.0066T 0.0005T
-0.100 -0.0039	-0.156 -0.0061	0.156T 0.000T 0.0061T 0.0000T	-0.100 -0.0039	-0.190 -0.0075	0.190T 0.000T 0.0075T 0.0000T
-0.120 -0.0047	-0.186 -0.0073	0.186T 0.005L 0.0073T 0.0002L	-0.120 -0.0047	-0.225 -0.0089	0.225T 0.005T 0.0089T 0.0002T
-0.140 -0.0055	-0.218 -0.0086	0.218T 0.020L 0.0086T 0.0008L	-0.140 -0.0055	-0.265 -0.0104	0.265T 0.020L 0.0104T 0.0008L
-0.170 -0.0067	-0.262 -0.0103	0.262T 0.030L 0.0103T 0.0012L	-0.170 -0.0067	-0.320 -0.0126	0.320T 0.030L 0.0126T 0.0012L
-0.195 -0.0077	-0.305 -0.0120	0.305T 0.055L 0.0120T 0.0021L	-0.195 -0.0077	-0.370 -0.0146	0.370T 0.055L 0.0146T 0.0021L

5200, A5200 METRIC SERIES SHAFT AND HOUSING FITS AND TOLERANCES

TABLE 13. SHAFT FITS⁽¹⁾

Bearing Bore		Bore Tolerance ⁽²⁾	Press Fit Rotating Inner Ring				Slip Fit Stationary Inner Ring			
Over	Incl.		Shaft Diameter		Fit		Shaft Diameter		Fit	
mm in.	mm in.		mm in.	mm in.	mm in.	mm in.	mm in.	mm in.	mm in.	mm in.
80 3.1496	120 4.7236	-0.020 -0.0008	+0.048 +0.0019	+0.025 +0.0010	0.025T 0.0010T	0.069T 0.0027T	0.000 0.0000	-0.023 -0.0009	0.023L 0.0009L	0.020T 0.0008T
120 4.7236	140 5.5108	-0.025 -0.0010	+0.056 +0.0022	+0.030 +0.0012	0.030T 0.0012T	0.081T 0.0032T	0.000 0.0000	-0.025 -0.0010	0.025L 0.0010L	0.025T 0.0010T
140 5.5108	180 7.0856	-0.025 -0.0010	+0.071 +0.0028	+0.046 +0.0018	0.046T 0.0018T	0.097T 0.0038T	0.000 0.0000	-0.025 -0.0010	0.025L 0.0010L	0.025T 0.0010T
180 7.0856	240 9.4476	-0.030 -0.0012	+0.081 +0.0032	+0.051 +0.0020	0.051T 0.0020T	0.112T 0.0044T	0.000 0.0000	-0.030 -0.0012	0.030L 0.0012L	0.030T 0.0012T

⁽¹⁾When shaft is used as ring surface, hardness to be Rc58 minimum and surface finish to be 15 RMS.

⁽²⁾Tolerance range is from +0 to value listed.

TABLE 14. HOUSING FITS

Bearing O.D.		O.D. Tolerance ⁽¹⁾	Slip Fit Stationary Outer Ring				Press Fit Rotating Outer Ring			
Over	Incl.		Housing Diameter		Fit		Housing Diameter		Fit	
mm in.	mm in.		mm in.	mm in.	mm in.	mm in.	mm in.	mm in.	mm in.	mm in.
-	180 7.0866	-0.025 -0.0010	+0.022 +0.0008	-0.015 -0.0006	0.015T 0.0006T	0.046L 0.0018L	-0.025 -0.0010	-0.056 -0.0022	0.056T 0.0022T	0.000L 0.0000L
180 7.0866	200 7.8740	-0.030 -0.0012	+0.018 +0.0007	-0.018 -0.0007	0.018T 0.0007T	0.048L 0.0019L	-0.030 -0.0012	-0.066 -0.0026	0.066T 0.0026T	0.000L 0.0000L
200 7.874	230 9.0551	-0.030 -0.0012	+0.023 +0.0009	-0.018 -0.0007	0.018T 0.0007T	0.053L 0.0021L	-0.030 -0.0012	-0.066 -0.0026	0.066T 0.0026T	0.000L 0.0000L
230 9.0551	250 9.8425	-0.030 -0.0012	+0.028 +0.0011	-0.018 -0.0007	0.018T 0.0007T	0.058L 0.0023L	-0.030 -0.0012	-0.066 -0.0026	0.066T 0.0026T	0.000L 0.0000L
250 9.8425	270 10.6299	-0.036 -0.0014	+0.028 +0.0011	-0.018 -0.0007	0.018T 0.0007T	0.064L 0.0025L	-0.030 -0.0012	-0.071 -0.0028	0.071T 0.0028T	0.005L 0.0002L
270 10.6299	310 12.2047	-0.036 -0.0014	+0.033 +0.0013	-0.018 -0.0007	0.018T 0.0007T	0.069L 0.0027L	-0.036 -0.0014	-0.071 -0.0028	0.071T 0.0028T	0.005L 0.0002L
310 12.2047	400 15.7480	-0.041 -0.0016	+0.038 +0.0015	-0.018 -0.0007	0.018T 0.0007T	0.079L 0.0031L	-0.036 -0.0014	-0.076 -0.0030	0.079T 0.0030T	0.005L 0.0002L
400 15.748	440 17.3228	-0.046 -0.0018	+0.041 +0.0016	-0.023 -0.0009	0.023T 0.0009T	0.086L 0.0034L	-0.036 -0.0014	-0.086 -0.0034	0.086T 0.0034T	0.010L 0.0004L

⁽¹⁾Tolerance range is from +0 to value listed.

**TABLE 15. 5200 METRIC SERIES
RADIAL INTERNAL CLEARANCE (R6)**

Bearing Bore		Radial Internal Clearance	
Over	Incl.	Max.	Min.
mm in.	mm in.	mm in.	mm in.
–	100 3.937	0.183 0.0072	0.127 0.005
100 3.937	120 4.7244	0.188 0.0074	0.127 0.005
120 4.7244	140 5.5118	0.208 0.0082	0.142 0.0056
140 5.5118	170 6.6929	0.224 0.0088	0.152 0.006
170 6.6929	180 7.0866	0.229 0.009	0.152 0.006
180 7.0866	220 8.6614	0.254 0.01	0.173 0.0068
220 8.6614	240 9.4488	0.269 0.0106	0.183 0.0072

**TABLE 16. 5200 METRIC SERIES
INNER RING TOLERANCES**

Bearing Bore		Bore & Inner O.D. ⁽¹⁾	Width +0
Over	Incl.		
mm in.	mm in.	mm in.	mm in.
80 3.1496	120 4.7244	-0.020 -0.0008	-0.203 -0.0080
120 4.7244	80 7.0866	-0.025 -0.0010	-0.254 -0.0100
180 7.0866	250 9.8425	-0.030 -0.0012	-0.305 -0.0120

⁽¹⁾Tolerance range is from +0 to value listed.

**TABLE 17. 5200 METRIC SERIES
OUTER RING TOLERANCES**

Bearing Bore		O.D. ⁽¹⁾	Width +0
Over	Incl.		
mm in.	mm in.	mm in.	mm in.
150 5.9055	180 7.0866	-0.025 -0.0010	+0.036 +0.0014
180 7.0866	250 9.8425	-0.030 -0.0012	+0.041 +0.0016
250 9.8425	315 12.4016	-0.036 -0.0014	+0.046 +0.0018
315 12.4016	400 15.748	-0.041 -0.0016	+0.051 +0.0020
400 15.748	500 19.685	-0.046 -0.0018	+0.056 +0.0022

⁽¹⁾Tolerance range is from +0 to value listed.

**TABLE 18. 5200 BEARINGS WITHOUT INNER RING
SHAFT DIMENSIONS**

Bearing Number	Slip Fit Housing ⁽¹⁾		Press Fit Housing ⁽¹⁾	
	Max.	Min.	Max.	Min.
	mm in.	mm in.	mm in.	mm in.
5220 WS	121.064 4.7663	121.044 4.7655	121.036 4.7652	121.016 4.7644
5222 WS	133.007 5.2365	132.987 5.2357	132.969 5.235	132.949 5.2343
5224 WS	145.194 5.7163	145.174 5.7155	145.156 5.7148	145.136 5.714
5226 WS	155.042 6.104	155.016 6.103	155.004 6.1025	154.978 6.1015
5228 WS	168.529 6.635	168.504 6.634	168.491 6.6335	168.466 6.6325
5230 WS	181.623 7.1505	181.597 7.1495	181.587 7.149	181.559 7.148
5232 WS	193.713 7.6265	193.688 7.6255	193.675 7.625	193.65 7.624
5234 WS	205.562 8.093	205.537 8.092	205.524 8.0915	205.499 8.0905
5236 WS	216.37 8.5185	216.344 8.5175	216.319 8.5165	216.294 8.5155
5238 WS	229.032 9.017	229.001 9.0158	228.994 9.0155	228.963 9.0143
5240 WS	242.296 9.5392	242.265 9.538	242.245 9.5372	242.214 9.536
5244 WM	266.02 10.4725	265.971 10.4713	265.951 10.4705	265.92 10.4693
5248WM	291.292 11.4682	291.262 11.467	291.241 11.4662	291.211 11.465

⁽¹⁾All shaft diameters are based on a housing bore to housing O.D. ratio of 0.7.

OPERATING TEMPERATURES

Bearings operate in a wide range of applications and environments. In most cases, bearing operating temperature is not an issue. Some applications, however, operate at extreme speeds or in extreme temperature environments. In these cases, care must be taken not to exceed the temperature limits of the bearing. Minimum temperature limits are primarily based on lubricant capability. Maximum temperature limits are most often based on material and/or lubricant constraints, but also may be based on accuracy requirements of the equipment that the bearings are built into. These constraints/limitations are discussed below.

BEARING MATERIAL LIMITATIONS

Standard bearing steels with a standard heat treatment cannot maintain a minimum hardness of 58 HRC much above 120° C (250° F).

Dimensional stability of Timken bearings is managed through the proper selection of an appropriate heat-treat process. Standard Timken tapered roller and ball bearings are dimensionally stabilized from -54° C (-65° F) up to 120° C (250° F), while standard spherical roller bearings are dimensionally stabilized up to 200° C (392° F) and standard cylindrical roller bearings are stabilized up to 150° C (302° F). Upon request, these bearings can be ordered to higher levels of stability as listed below. These designations are in agreement with DIN Standard 623.

TABLE 19.

Stability Designation	Maximum Operating Temperature	
	°C	°F
S0	150	302
S1	200	392
S2	250	482
S3	300	572
S4	350	662

With dimensionally stabilized product, there still may be some changes in dimensions during service as a result of microstructural transformations. These transformations include the continued tempering of martensite and decomposition of retained austenite. The magnitude of change depends on the operating temperature, the time at temperature and the composition and heat-treatment of the steel.

Temperatures exceeding the limits shown in table 19 require special high-temperature steel. Consult your Timken engineer for availability of specific part numbers for non-standard heat stability or high-temperature steel grades.

Suggested materials for use in balls, rings and rollers at various operating temperatures are listed in table 20. Also listed are chemical composition recommendations, hardness recommendations and dimensional stability information.

Operating temperature affects lubricant film thickness and setting, both of which directly influence bearing life. Extremely high temperatures can result in a reduced film thickness that can lead to asperity contact between contacting surfaces.

Operating temperature also can affect performance of cages, seals and shields, which in turn can affect bearing performance. Materials for these components and their operating temperature ranges are shown in table 21.

LUBRICATION LIMITATIONS

Starting torque in grease-lubricated applications typically increases significantly at cold temperatures. Starting torque is not primarily a function of the consistency or channel properties of the grease. Most often, it is a function of the rheological properties of the grease.

The high-temperature limit for greases is generally a function of the thermal and oxidation stability of the base oil in the grease and the effectiveness of the oxidation inhibitors.

See the LUBRICATION AND SEALS section on page 45 for more information on lubrication limitations.

EQUIPMENT REQUIREMENTS

The equipment designer must evaluate the effects of temperature on the performance of the equipment being designed. Precision machine tool spindles, for example, can be very sensitive to thermal expansions. For some spindles, it is important that the temperature rise over ambient be held to 20° C to 35° C (36° F to 45° F).

Most industrial equipment can operate at considerably higher temperatures. Thermal ratings on gear drives, for example, are based on 93° C (200° F). Equipment such as gas turbines operates continuously at temperatures above 100° C (212° F). Running at high temperatures for extended periods of time, however, may affect shaft and housing fits, if the shaft and housing are not machined and heat-treated properly.

Although bearings can operate satisfactorily up to 120° C (250° F), an upper temperature limit of 80° C to 95° C (176° F to 203° F) is more practical. Higher operating temperatures increase the risk of damage from transient temperature spikes. Prototype testing of the application can help define the operating temperature range and should be conducted if possible. It is the responsibility of the equipment designer to weigh all relevant factors and make the final determination of satisfactory operating temperature.

Tables 20 and 21 provide standard operating temperatures for common bearing component materials. They should be used for reference purposes only. Other bearing component materials are available on request. Contact your Timken engineer for more information.

TABLE 20. OPERATING TEMPERATURES FOR BEARING COMPONENT MATERIALS

Material	Approximate Chemical Analysis %	Temp. °F	Hardness HRC	-73° C -100° F	-54° C -65° F	-17° C 0° F	38° C 100° F	93° C 200° F	121° C 250° F	149° C 300° F	204° C 400° F	260° C 500° F	316° C 600° F	371° C 700° F	427° C 800° F
Low-alloy carbon-chromium bearing steels. 52100 and others per ASTM A295	1C 0.5–1.5Cr 0.35Mn	70	60	STANDARD DIMENSIONAL STABILIZATION <0.0001 in./in dimensional change in 2500 hours at 100° C (212° F). Good oxidation resistance.											
Low-alloy carbon-chromium bearing steels. 52100 and others per ASTM A295	1C 0.5–1.5Cr 0.35Mn	70 350 450	58 56 54	Heat stabilized per FS136, <0.0001 in./in dimensional change in 2500 hours at 149° C (300° F). When given a stabilizing heat treatment, A295 steel is suitable for many applications in the 177°-232° C (350-450° F) range; however, it is not as dimensionally stable as it is at temperatures below 177° C (350° F). If utmost stability is required, use materials in the 316° C (600° F) group below.											
Deep-hardening steels for heavy sections per ASTM A485	1C 1–1.8Cr 1–1.5Mn .06Si	70 450 600	58 55 52	As heat-treated and tempered, it is stabilized, <0.0001 in./in dimensional change in 2500 hours at 149° C (300° F).											
Carburizing steels per ASTM A534 a) low alloy 4118, 8X19, 5019, 8620 (Ni-Moly grades) b) high nickel 3310	Ni-Moly: 0.2C, 0.4-2.0Mn, 0.3-0.8Cr, 0-2.0Ni, 0-0.3Mo .01C, 1.5Cr, 0.4Mn, 3.5Ni	70	58	Nickel-Moly grades of steel frequently used to achieve extra ductility in inner rings for locking device bearings. 3311 and others used for extra-thick-section rings.											
Corrosion-resistant 440C stainless steel per ASTM A756	1C 18Cr	70	58	Excellent corrosion resistance.											
Corrosion-resistant 440C stainless steel per ASTM A756	1C 18Cr	70 450 600	58 55 52	As heat stabilized for maximum hardness at high temperatures (FS238). Good oxidation resistance at higher temperatures. Note load capacity drops off more rapidly at higher temperatures than M50 shown below, which should be considered if loads are high, <0.0001 in./in dimensional change in 1200 hours.											
M-50 medium high speed	4Cr 4Mo 1V 0.8C	70 450 600	60 59 57	Suggested where stable high hardness at elevated temperature is required, <0.0001 in./in dimensional change in 1200 hours at 316° C (600° F).											

Note: Dimensional stability data shown above is the permanent metallurgical growth and/or shrinkage only. Thermal expansion effects are not included. For operating temperatures above 427° C (800° F), consult your Timken engineer.

TABLE 21. OPERATING TEMPERATURES FOR BEARING COMPONENT MATERIALS

	-54° C -65° F	-17° C 0° F	38° C 100° F	93° C 200° F	149° C 300° F	204° C 400° F	260° C 500° F	316° C 600° F	371° C 700° F	427° C 800° F
CAGES										
Molded 6/6 nylon (PRB)										
Molded 6/6 fiberglass reinforced nylon (PRC)										
Phenolic resin laminate										
Low-carbon pressed steel										
Pressed stainless steel										
Machined bronze										
Machined iron-silicon bronze										
Machined steel										
SHIELDS										
Low-carbon steel										
Stainless steel										
Nylon										
SEALS										
Buna N										
Polyacrylic										
Fluoroelastomer										
Stabilized TFE fluorocarbon ⁽¹⁾										
TFE fluorocarbon ⁽¹⁾ (with glass fabric)										

⁽¹⁾Limited life above these temperatures.

HEAT GENERATION AND DISSIPATION

Bearing operating temperature is dependent upon a number of factors, including heat generation of all contributing heat sources, heat flow rate between sources and the ability of the system to dissipate the heat. Heat sources include such things as bearings, seals, gears, clutches and oil supply. Heat dissipation is affected by many factors, including shaft and housing materials and designs, lubricant circulation and external environmental conditions. These and other factors are discussed in the following sections.

HEAT GENERATION

Under normal operating conditions, most of the torque and heat generated by the bearing is caused by the elastohydrodynamic losses at the roller/ring contacts.

Heat generation is the product of bearing torque and speed. The following equation is used to calculate the heat generated.

$$Q_{\text{gen}} = k_4 n M$$

If the bearing is a cylindrical roller bearing, the torque calculations are given in the subsequent sections.

HEAT DISSIPATION

The problem of determining the heat flow from a bearing in a specific application is rather complex. In general, it can be said that factors affecting the rate of heat dissipation include the following:

1. Temperature gradient from the bearing to the housing. This is affected by size configuration of the house and any external cooling such as fans, water cooling or fan action of the rotating components.
2. Temperature gradient from the bearing to the shaft. Any other heat sources, such as gears and additional bearings and their proximity to the bearing considered, will influence the temperature of the shaft.
3. The heat carried away by a circulating oil system.

To what extent nos. 1 and 2 can be controlled will depend on the application. The heat-dissipation modes include conduction through the system, convection along the inside and outside surfaces of the system, as well as radiation exchange to and from neighboring structures. In many applications, overall heat dissipation can be divided into two categories – heat removed by circulating oil and heat removed through the structure.

Heat dissipation by circulating oil

The amount of heat removed by the lubricant can be controlled more easily. In a splash lubrication system, cooling coils may be used to control the bulk oil temperature.

The amount of heat carried away in a circulating oil system by the lubricant can be approximated from the following equations.

$$Q_{\text{oil}} = k_6 C_p \rho f (\theta_o - \theta_i)$$

Where:

$$\begin{aligned} k_6 &= 1.67 \times 10^{-5} \text{ for } Q_{\text{oil}} \text{ in W} \\ &= 1.67 \times 10^{-2} \text{ for } Q_{\text{oil}} \text{ in Btu/min} \end{aligned}$$

If the circulating lubricant is petroleum oil, the heat removed is further approximated by the following:

$$Q_{\text{oil}} = k_5 f (\theta_o - \theta_i)$$

The following factors apply to the heat generation and dissipation equations listed on this page.

Where:

$$\begin{aligned} k_5 &= 28 \text{ for } Q_{\text{oil}} \text{ in W when } f \text{ in L/min and } \theta \text{ in } ^\circ\text{C} \\ &= 0.42 \text{ for } Q_{\text{oil}} \text{ in Btu/min when } f \text{ in U.S. pt/min} \\ &\text{and } \theta \text{ in } ^\circ\text{F} \end{aligned}$$

TORQUE

RUNNING TORQUE-M

The rotational resistance of a rolling bearing is dependent on load, speed, lubrication conditions and bearing internal characteristics.

The following formulas yield approximations to values of bearing running torque. The formulas apply to bearings lubricated by oil. For bearings lubricated by grease or oil mist, torque is usually lower, although for grease lubrication this depends on amount and consistency of the grease. The formulas also assume the bearing running torque has stabilized after an initial period referred to as running-in.

CYLINDRICAL ROLLER BEARINGS

The torque equations for cylindrical roller bearings are given as follows, where the coefficients are based on series and found in the following table:

$$M = \begin{cases} f_1 F_{\beta} dm + 10^{-7} f_0 (v \times n)^{2/3} dm^3 & \text{if } (v \times n) \geq 2000 \\ f_1 F_{\beta} dm + 160 \times 10^{-7} f_0 dm^3 & \text{if } (v \times n) < 2000 \end{cases}$$

Note that the viscosity is in units of centistokes. The load term (F_{β}) depends on the bearing type as follows:

Radial cylindrical roller:
$$F_{\beta} = \max \left(\begin{matrix} 0.8F_a \cot \alpha \\ \text{or} \\ F_r \end{matrix} \right)$$

TABLE 22. COEFFICIENTS FOR THE TORQUE EQUATION

Bearing Type	Dimension Series	f_0	f_1
Single-row cylindrical roller bearings with cage	10	2	0.00020
	02	2	0.00030
	22	3	0.00040
	03	2	0.00035
	23	4	0.00040
Single-row cylindrical roller bearings full-complement	04	2	0.00040
	18	5	0.00055
	29	6	0.00055
	30	7	0.00055
	22	8	0.00055
Double-row cylindrical roller bearings full-complement	23	12	0.00055
	48	9	0.00055
	49	11	0.00055
	50	13	0.00055

LUBRICATION

To help maintain a bearing's antifriction characteristics, lubrication is needed to:

- Minimize rolling resistance due to deformation of the rolling elements and raceway under load by separating the mating surfaces.
- Minimize sliding friction occurring between rolling elements, raceways and cage.
- Transfer heat (with oil lubrication).
- Protect from corrosion and, with grease lubrication, from contaminant ingress.



LUBRICATION

The wide range of bearing types and operating conditions precludes any simple, all-inclusive statement or guideline allowing the selection of the proper lubricant. At the design level, the first consideration is whether oil or grease is best for the particular operation. The advantages of oil and grease are outlined in the table below. When heat must be carried away from the bearing, oil must be used. It is almost always preferred for very high-speed applications.

TABLE 23. ADVANTAGES OF OIL AND GREASE

Oil	Grease
Carries heat away from the bearings	Simplifies seal design and acts as a sealant
Carries away moisture and particulate matter	Permits prelubrication of sealed or shielded bearings
Easily controlled lubrication	Generally requires less frequent lubrication

European REACH compliance

Timken-branded lubricants, greases and similar products sold in stand-alone containers or delivery systems are subject to the European REACH (**R**egistration, **E**valuation, **A**uthorization and **R**estriction of **C**hemicals) directive. For import into the European Union, Timken can sell and provide only those lubricants and greases that are registered with ECHA (European CHemical Agency). For further information, please contact your Timken engineer.

OIL LUBRICATION

Oils used for bearing lubrication should be high-quality mineral oils or synthetic oils with similar properties. Selection of the proper type of oils depends on bearing speed, load, operating temperature and lubrication method. Some features and advantages of oil lubrication, in addition to the above are:

- Oil is a better lubricant for high speeds or high temperatures. It can be cooled to help reduce bearing temperature.
- It is easier to handle and control the amount of lubricant reaching the bearing. It is harder to retain in the bearing. Lubricant losses may be higher than with grease.
- Oil can be introduced to the bearing in many ways, such as drip-feed, wick-feed, pressurized circulating systems, oil bath or air-oil mist. Each is suited for certain types of applications.
- Oil is easier to keep clean for recirculating systems.

Oil may be introduced to the bearing housing in many ways. The most common systems are:

- **Oil bath.** The housing is designed to provide a sump through which the rolling elements of the bearing will pass. Generally, the oil level should be no higher than the center

point of the lowest rolling element. If speed is high, lower oil levels should be used to reduce churning. Gages or controlled elevation drains are used to achieve and maintain the proper oil level.

- **Circulating system.** This system has the advantages of:
 - An adequate supply of oil for both cooling and lubrication.
 - Metered control of the quantity of oil delivered to each bearing.
 - Removal of contaminants and moisture from the bearing by flushing action.
 - Suitability for multiple bearing installations.
 - Large reservoir, which reduces deterioration. Increased lubricant life provides economical efficiency.
 - Incorporation of oil-filtering devices.
 - Positive control to deliver the lubricant where needed.
 - A typical circulating oil system consists of an oil reservoir, pump, piping and filter. A heat exchange may be required.
- **Oil-mist lubrication.** Oil-mist lubrication systems are used in high-speed, continuous-operation applications. This system permits close control of the amount of lubricant reaching the bearings. The oil may be metered, atomized by compressed air and mixed with air, or it may be picked up from a reservoir using a venturi effect. In either case, the air is filtered and supplied under sufficient pressure to assure adequate lubrication of the bearings. Control of this type of lubrication system is accomplished by monitoring the operating temperatures of the bearings being lubricated. The continuous passage of the pressurized air and oil through the labyrinth seals used in the system prevents the entrance of contaminants from the atmosphere to the system.

The successful operation of this type of system is based upon the following factors:

- Proper location of the lubricant entry ports in relation to the bearings being lubricated.
- Avoidance of excessive pressure drops across void spaces within the system.
- Proper air pressure and oil quantity ratio to suit the particular application.
- Adequate exhaust of the air-oil mist after lubrication has been accomplished.

To ensure “wetting” of the bearings, and to prevent possible damage to the rolling elements and rings, it is

imperative that the oil-mist system be turned on for several minutes before the equipment is started. The importance of “wetting” the bearing before starting cannot be overstated, and it also has particular significance for equipment that has been idled for extended periods of time.

Lubricating oils are commercially available in many forms for automotive, industrial, aircraft and other uses. Oils are classified as either petroleum types (refined from crude oil) or synthetic types (produced by chemical synthesis).

PETROLEUM OILS

Petroleum oils are made from a petroleum hydrocarbon derived from crude oil, with additives to improve certain properties. Petroleum oils are used for nearly all oil-lubricated applications of bearings.

SYNTHETIC OILS

Synthetic oils cover a broad range of categories and include polyalphaolefins, silicones, polyglycols and various esters. In general, synthetic oils are less prone to oxidation and can operate at extreme hot or cold temperatures. Physical properties, such as pressure-viscosity coefficients, tend to vary between oil types; use caution when making oil selections.

The polyalphaolefins (PAO) have a hydrocarbon chemistry that parallels petroleum oil both in chemical structures and pressure-viscosity coefficients. Therefore, PAO oil is mostly used in the oil-lubricated applications of bearings when severe temperature environments (hot and cold) are encountered or when extended lubricant life is required.

The silicone, ester and polyglycol oils have an oxygen-based chemistry that is structurally quite different from petroleum oils and PAO oils. This difference has a profound effect on its physical properties where pressure-viscosity coefficients can be lower compared to mineral and PAO oils. This means that these types of synthetic oils may actually generate a smaller elastohydrodynamic (EHD) film thickness than a mineral or PAO oil of equal viscosity at operating temperature. Reductions in bearing fatigue life and increases in bearing wear could result from this reduction of lubricant film thickness.

VISCOSITY

The selection of oil viscosity for any bearing application requires consideration of several factors: load, speed, bearing setting, type of oil and environmental factors. Since oil viscosity varies inversely with temperature, a viscosity value must always be stated with the temperature at which it was determined. High-viscosity oil is used for low-speed or high-ambient-temperature applications. Low-viscosity oil is used for high-speed or low-ambient-temperature applications.

There are several classifications of oils based on viscosity grades. The most familiar are the Society of Automotive Engineers (SAE) classifications for automotive engine and gear oils. The American Society for Testing and Materials (ASTM) and the International Organization for Standardization (ISO) have adopted standard viscosity grades for industrial fluids. Fig. 12 shows the viscosity comparisons of ISO/ASTM with SAE classification systems at 40° C (104° F).

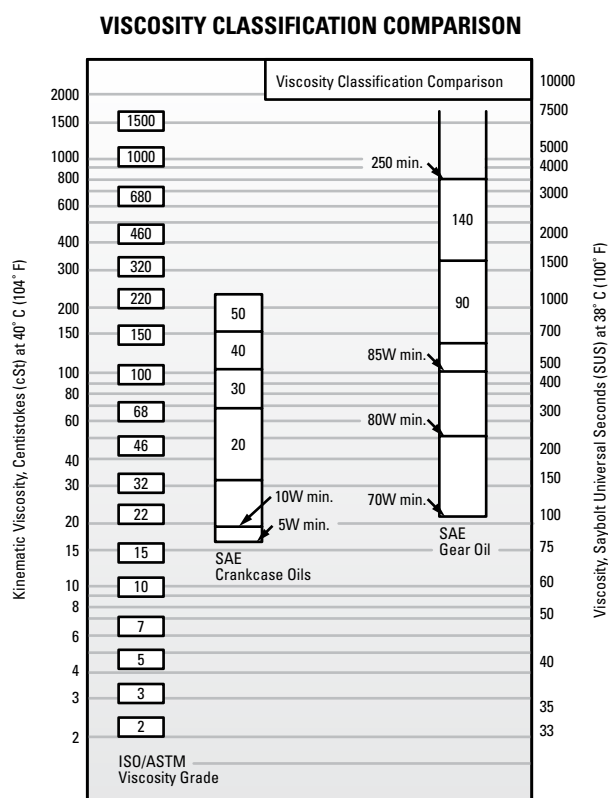

Fig. 12. Comparison between ISO/ASTM grades (ISO 3448/ASTM D2442) and SAE grades (SAE J 300-80 for crankcase oils, SAE J 306-81 for axle and manual transmission oils).

The ASTM/ISO viscosity grade system for industrial oils is depicted below.

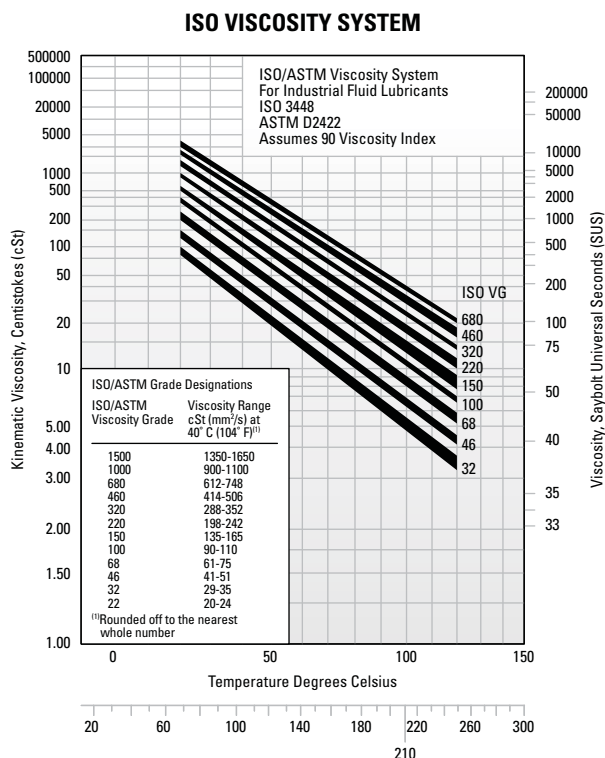

Fig. 13. Viscosity grade system for industrial oils.

TYPICAL BEARING LUBRICATION OILS

In this section, the properties and characteristics of lubricants for typical roller bearing applications are listed. These general characteristics are derived from successful performance in applications across all industries.

General-purpose rust and oxidation lubricating oil

General-purpose rust and oxidation (R&O) inhibited oils are the most common type of industrial lubricant. They are used to lubricate Timken® bearings in all types of industrial applications where conditions requiring special considerations do not exist.

TABLE 24. SUGGESTED GENERAL PURPOSE R&O LUBRICATING OIL PROPERTIES

Properties	
Base stock	Solvent-refined, high-viscosity-index petroleum oil
Additives	Corrosion and oxidation inhibitors
Viscosity index	80 min.
Pour point	-10° C max. (14° F)
Viscosity grades	ISO/ASTM 32 through 220

Some low-speed and/or high-ambient-temperature applications require the higher viscosity grades. High-speed and/or low-temperature applications require the lower viscosity grades.

Industrial extreme-pressure (EP) gear oil

Extreme-pressure gear oils are used to lubricate Timken bearings in most types of heavily loaded industrial equipment. They should be capable of withstanding abnormal shock loads that are common in heavy-duty equipment.

TABLE 25. SUGGESTED INDUSTRIAL EP GEAR OIL PROPERTIES

Properties	
Base stock	Solvent-refined, high-viscosity-index petroleum oil
Additives	Corrosion and oxidation inhibitors Extreme-pressure (EP) additive ⁽¹⁾ - 15.8 kg (35 lb.) min.
Viscosity index	80 min.
Pour point	-10° C max. (14° F)
Viscosity grades	ISO/ASTM 100, 150, 220, 320, 460

⁽¹⁾ ASTM D 2782

Industrial EP gear oils should be composed of a highly refined petroleum oil-based stock plus appropriate inhibitors and additives. They should not contain materials that are corrosive or abrasive to bearings. The inhibitors should provide long-term protection from oxidation and protect the bearing from corrosion in the presence of moisture. The oils should resist foaming in service and have good water-separation properties. An EP additive protects against scoring under boundary-lubrication conditions. The viscosity grades suggested represent a wide range. High-temperature and/or slow-speed applications generally require the higher viscosity grades. Low temperatures and/or high speeds require the use of lower viscosity grades.

GREASE LUBRICATION

Grease lubrication is generally applicable to low-to-moderate speed applications that have operating temperatures within the limits of the grease. There is no universal antifriction bearing grease. Each grease has limiting properties and characteristics.

Greases consist of a base oil, a thickening agent and additives. Conventionally, bearing greases have consisted of petroleum base oils thickened to the desired consistency by some form of metallic soap. More recently synthetic base oils have been used with organic and inorganic thickeners. Table 26 summarizes the composition of typical lubricating greases.

TABLE 26. COMPOSITION OF GREASES

Base Oil	+	Thickening Agents	+	Additives	=	Lubricating Grease
Mineral oil		Soaps and complex soaps		Rust inhibitors		
Synthetic hydrocarbon		lithium, aluminum, barium, calcium		Dyes		
Esters		Non-Soap (inorganic)		Tactifiers		
Perfluorinated oil		microgel (clay), carbon black, silica-gel, PTFE		Metal deactivates		
Silicone		Non-Soap (organic)		Oxidation inhibitors		
		Polyurea compounds		Anti-wear EP		

Calcium- and aluminum-based greases have excellent water resistance and are used in industrial applications where water ingress is an issue. Lithium-based greases are multi-purpose and are used in industrial applications and wheel bearings.

Synthetic base oils such as esters, organic esters and silicones used with conventional thickeners and additives typically have higher maximum operating temperatures than petroleum-based greases. Synthetic greases can be designed to operate in temperatures from -73° C (-100° F) to 288° C (550° F).

Below are the general characteristics of common thickeners used with petroleum base oils.

TABLE 27. GENERAL CHARACTERISTICS OF THICKENERS USED WITH PETROLEUM BASE OILS

Thickener	Typical Dropping Point		Maximum Temperature		Typical Water Resistance
	°C	°F	°C	°F	
Lithium soap	193	380	121	250	Good
Lithium complex	260+	500+	149	300	Good
Aluminum complex	249	480	149	300	Excellent
Calcium sulfonate	299	570	177	350	Excellent
Polyurea	260	500	149	300	Good

Use of the thickeners in table 27 with synthetic hydrocarbon or ester base oils increases the maximum operating temperature by approximately 10° C (50° F).

Using polyurea as a thickener for lubricating fluids is one of the most significant lubrication developments in more than 30 years. Polyurea grease performance is outstanding in a wide range of bearing applications and, in a relatively short time, it has gained acceptance as a factory-packed lubricant for ball bearings.

LOW TEMPERATURES

Starting torque in a grease-lubricated bearing at low temperatures can be critical. Some greases may function adequately as long as the bearing is operating, but resistance to initial movement may be excessive. In certain smaller machines, starting may be impossible when very cold. Under such operating circumstances, greases containing low-temperature characteristic oils are generally required.

If the operating temperature range is wide, synthetic greases offer advantages. Synthetic greases are available to provide very low starting and running torque at temperatures as low as -73° C (-100° F). In certain instances, these greases perform better in this respect than oil.

An important point concerning lubricating greases is that the starting torque is not necessarily a function of the consistency or the channel properties of the grease. Starting torque is more a function of the individual rheological properties of a particular grease and is best evaluated by application experience.

HIGH TEMPERATURES

The high temperature limit for lubricating greases is generally a function of the thermal and oxidation stability of the fluid and the effectiveness of the oxidation inhibitors. Grease temperature ranges are defined by both the dropping point of the grease thickener and composition of the base oil. Table 28 shows the temperature ranges of various base oils used in grease formulations.

A rule of thumb, developed from years of testing grease-lubricated bearings, indicates that grease life is halved for every 10° C (50° F) increase in temperature. For example, if a particular grease provides 2000 hours of life at 90° C (194° F), by raising the temperature to 100° C (212° F), reduction in life to approximately 1000 hours would result. On the other hand, 4000 hours could be expected by lowering the temperature to 80° C (176° F).

Thermal stability, oxidation resistance and temperature limitations must be considered when selecting greases for high-temperature applications. In non-relubricatable applications, highly refined mineral oils or chemically stable synthetic fluids are required as the oil component of greases for operation at temperatures above 121° C (250° F).

TABLE 28. TEMPERATURE RANGES FOR BASE OILS USED IN LUBRICATING GREASES

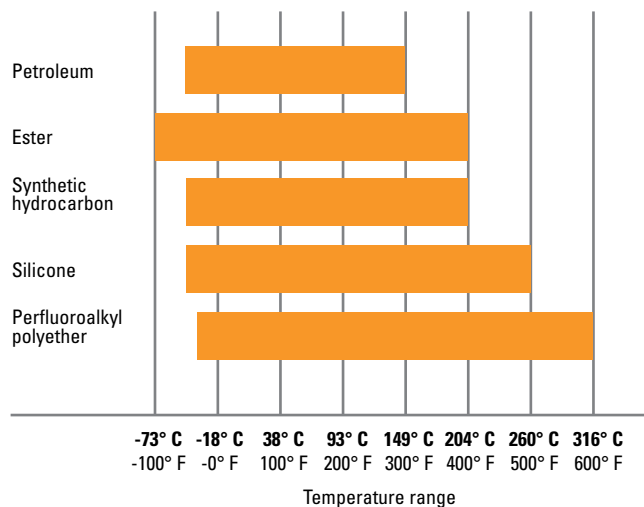

CONTAMINATION

Abrasive Particles

When roller bearings operate in a clean environment, the primary cause of damage is the eventual fatigue of the surfaces where rolling contact occurs. However, when particle contamination enters the bearing system, it is likely to cause damage such as bruising, which can shorten bearing life.

When dirt from the environment or metallic wear debris from some component in the application are allowed to contaminate the lubricant, wear can become the predominant cause of bearing damage. If bearing wear becomes significant, changes will occur to critical bearing dimensions that could adversely affect machine operation.

Bearings operating in a contaminated lubricant exhibit a higher initial rate of wear than those running in an uncontaminated lubricant. With no further contaminant ingress, this wear rate quickly diminishes. The contamination particles are reduced in size as they pass through the bearing contact area during normal operation.

Water

Water and moisture can be particularly conducive to bearing damage. Lubricating greases may provide a measure of protection from this contamination. Certain greases, such as calcium and aluminum-complex, are highly water-resistant.

Sodium-soap greases are water-soluble and should not be used in applications involving water.

Either dissolved or suspended water in lubricating oils can exert a detrimental influence on bearing fatigue life. Water can cause bearing etching that also can reduce bearing fatigue life. The exact mechanism by which water lowers fatigue life is not fully understood. It has been suggested that water enters micro-cracks in the bearing rings that are caused by repeated stress cycles. This leads to corrosion and hydrogen embrittlement in the micro-cracks, reducing the time required for these cracks to propagate to an unacceptable-sized spall.

Water-based fluids, such as water glycol and invert emulsions, also have shown a reduction in bearing fatigue life. Although water from these sources is not the same as contamination, the results support the previous discussion concerning water-contaminated lubricants.

GREASE SELECTION

The successful use of bearing grease depends on the physical and chemical properties of the lubricant as well as application and environmental conditions. Because the choice of grease for a particular bearing under certain service conditions is often difficult to make, you should consult with your lubricant supplier or equipment maker for specific questions about lubrication requirements for your application. You also can contact your Timken engineer for general lubrication guidelines for any application.

Grease must be carefully selected with regard to its consistency at operating temperature. It should not exhibit thickening, separation of oil, acid formation or hardening to any marked degree. It should be smooth, non-fibrous and entirely free from chemically active ingredients. Its dropping point should be considerably higher than the operating temperature.

Timken® application-specific lubricants were developed by leveraging our knowledge of tribology and antifriction bearings, and how these two elements affect overall system performance. Timken lubricants help bearings and related components operate effectively in demanding industrial operations. High-temperature, anti-wear and water-resistant additives offer superior protection in challenging environments. Table 29 provides an overview of the Timken greases available for general applications. Contact your Timken engineer for a more detailed publication on Timken lubrication solutions.

TABLE 29. GREASE LUBRICATION SELECTION GUIDE

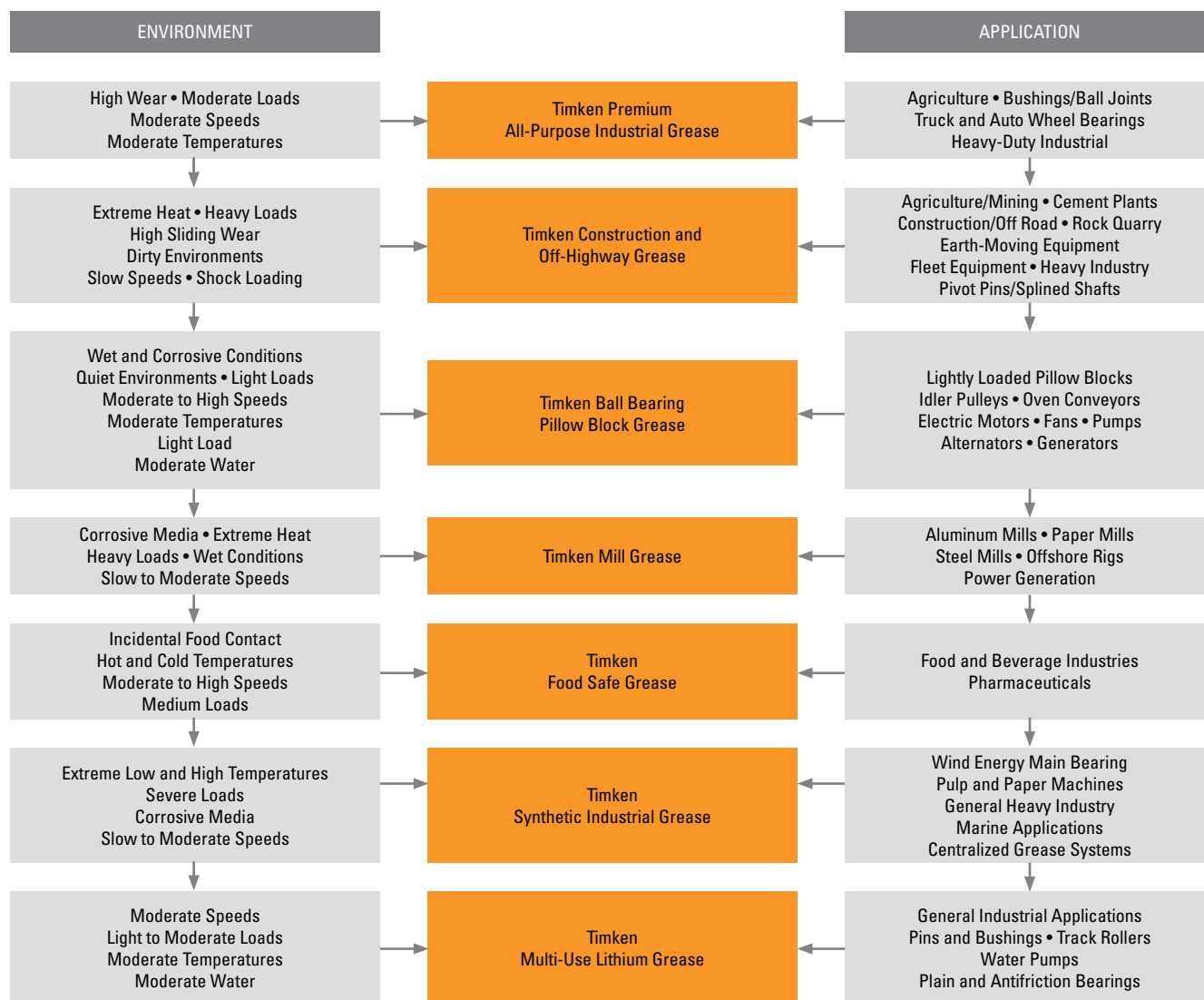

This selection guide is not intended to replace the specifications by the equipment builder, who is responsible for its performance.

Many bearing applications require lubricants with special properties or lubricants formulated specifically for certain environments, such as:

- Friction oxidation (fretting corrosion).
- Chemical and solvent resistance.
- Food handling.
- Quiet running.
- Space and/or vacuum.
- Electrical conductivity.

For assistance with these or other areas requiring special lubricants, consult your Timken engineer.

GREASE USE GUIDELINES

It is important to use the proper amount of grease in the application. In typical industrial applications, the bearing cavity should be kept approximately one-third to one-half full. Less grease may result in the bearing being starved for lubrication. More grease may result in churning. Both conditions may result in excessive heat generation. As the grease temperature rises, viscosity decreases and the grease becomes thinner. This can reduce the lubricating effect and increase leakage of the grease from the bearing. It also may cause the grease components to separate, leading to a general breakdown of the lubricant properties. As the grease breaks down, bearing torque increases. In the case of excess grease resulting in churning, torque may also increase due to the resistance caused by the grease.

For best results, there should be ample space in the housing to allow room for excess grease to be thrown from the bearing. However, it is equally important that the grease be retained all around the bearing. If a large void exists between the bearings, grease closures should be used to prevent the grease from leaving the bearing area.

Only in low-speed applications may the housing be entirely filled with grease. This method of lubrication is a safeguard against the entry of foreign matter, where sealing provisions are inadequate for exclusion of contaminants or moisture.

During periods of non-operation, it is often wise to completely fill the housings with grease to protect the bearing surfaces. Prior to restarting operation, remove the excess grease and restore the proper level.

Applications utilizing grease lubrication should have a grease fitting and a vent at opposite ends of the housing near the top. A drain plug should be located near the bottom of the housing to allow the old grease to purge from the bearing.

Bearings should be relubricated at regular intervals to help prevent damage. Relubrication intervals are difficult to determine. If plant practice or experience with other applications is not available, consult your lubricant supplier.

Timken offers a range of lubricants to help bearings and related components operate effectively in demanding industrial operations. High-temperature, anti-wear and water-resistant additives offer greater protection in challenging environments. Timken also offers a line of single- and multi-point lubricators to simplify grease delivery.



Fig. 14. Grease can easily be packed by hand.



Fig. 15. Mechanical grease packer.

Grease application methods

Grease, in general, is easier to use than oil in industrial bearing lubrication applications. Most bearings that are initially packed with grease require periodic relubrication to operate efficiently.

Grease should be packed into the bearing so that it gets between the rolling elements – the rollers or balls. For tapered roller bearings, forcing grease through the bearing from the large end to the small end will ensure proper distribution.

Grease can be easily packed into small- and medium-size bearings by hand (fig. 14). In shops where bearings are frequently regreased, a mechanical grease packer that forces grease through the bearing under pressure may be appropriate (fig. 15). Regardless of the method, after packing the internal areas of the bearing, a small amount of grease also should be smeared on the outside of the rollers or balls.

The two primary considerations that determine the relubrication cycle are operating temperature and sealing efficiency. High-operating-temperature applications generally require more frequent regreasing. The less efficient the seals, the greater the grease loss and the more frequently grease must be added.

Grease should be added any time the amount in the bearing falls below the desired amount. The grease should be replaced when its lubrication properties have been reduced through contamination, high temperature, water, oxidation or any other factors. For additional information on appropriate regreasing cycles, consult with the equipment manufacturer or your Timken engineer.

CONSISTENCY

Greases may vary in consistency from semi-fluids that are hardly thicker than a viscous oil to solid grades almost as hard as a soft wood.

Consistency is measured by a penetrometer in which a standard weighted cone is dropped into the grease. The distance the cone penetrates (measured in tenths of a millimeter in a specific time) is the penetration number.

The National Lubricating Grease Institute (NLGI) classification of grease consistency is shown below:

TABLE 30. NLGI CLASSIFICATIONS

NLGI Grease Grades	Penetration Number
0	355-385
1	310-340
2	265-295
3	220-250
4	175-205
5	130-160
6	85-115

Grease consistency is not fixed; it normally becomes softer when sheared or “worked.” In the laboratory, this “working” is accomplished by forcing a perforated plate up and down through a closed container of grease. This “working” does not compare with the violent shearing action that takes place in a bearing and does not necessarily correlate with actual performance.

TABLE 31. GREASE COMPATIBILITY CHART

	Al Complex	Ba Complex	Ca Stearate	Ca 12 Hydroxy	Ca Complex	Ca Sulfonate	Clay Non-Soap	Li Stearate	Li 12 Hydroxy	Li Complex	Polyurea	Polyurea S S
Aluminum Complex	Best Choice	Incompatible	Incompatible	Compatible	Incompatible	Borderline	Incompatible	Incompatible	Incompatible	Compatible	Incompatible	Compatible
Timken Food Safe	Best Choice	Incompatible	Incompatible	Compatible	Incompatible	Borderline	Incompatible	Incompatible	Incompatible	Compatible	Incompatible	Compatible
Barium Complex	Incompatible	Best Choice	Incompatible	Compatible	Incompatible	Compatible	Incompatible	Incompatible	Incompatible	Incompatible	Incompatible	Borderline
Calcium Stearate	Incompatible	Incompatible	Best Choice	Compatible	Incompatible	Compatible	Compatible	Compatible	Borderline	Compatible	Incompatible	Compatible
Calcium 12 Hydroxy	Compatible	Compatible	Compatible	Best Choice	Borderline	Borderline	Compatible	Compatible	Compatible	Compatible	Incompatible	Compatible
Calcium Complex	Incompatible	Incompatible	Incompatible	Borderline	Best Choice	Incompatible	Incompatible	Incompatible	Incompatible	Compatible	Compatible	Compatible
Calcium Sulfonate	Borderline	Compatible	Compatible	Borderline	Incompatible	Best Choice	Incompatible	Borderline	Borderline	Compatible	Incompatible	Compatible
Timken Premium Mill Timken Heavy-Duty Moly	Borderline	Compatible	Compatible	Borderline	Incompatible	Best Choice	Incompatible	Borderline	Borderline	Compatible	Incompatible	Compatible
Clay Non-Soap	Incompatible	Incompatible	Compatible	Compatible	Incompatible	Incompatible	Best Choice	Incompatible	Incompatible	Incompatible	Incompatible	Borderline
Lithium Stearate	Incompatible	Incompatible	Compatible	Compatible	Incompatible	Borderline	Incompatible	Best Choice	Compatible	Compatible	Incompatible	Compatible
Lithium 12 Hydroxy	Incompatible	Incompatible	Borderline	Compatible	Incompatible	Borderline	Incompatible	Compatible	Best Choice	Compatible	Incompatible	Compatible
Lithium Complex	Compatible	Incompatible	Compatible	Compatible	Compatible	Compatible	Incompatible	Compatible	Compatible	Best Choice	Incompatible	Compatible
Polyurea Conventional	Incompatible	Incompatible	Incompatible	Incompatible	Compatible	Incompatible	Incompatible	Incompatible	Incompatible	Incompatible	Best Choice	Compatible
Polyurea Shear Stable	Compatible	Borderline	Compatible	Compatible	Compatible	Compatible	Borderline	Compatible	Compatible	Compatible	Compatible	Best Choice
Timken Multi-Use	Incompatible	Incompatible	Borderline	Compatible	Incompatible	Borderline	Incompatible	Compatible	Best Choice	Compatible	Incompatible	Compatible
Timken All-Purpose Timken Synthetic	Compatible	Incompatible	Compatible	Compatible	Compatible	Compatible	Incompatible	Compatible	Compatible	Best Choice	Incompatible	Compatible
Timken Pillow Block	Compatible	Borderline	Compatible	Compatible	Compatible	Compatible	Borderline	Compatible	Compatible	Compatible	Compatible	Best Choice

NOTE

Mixing greases can result in improper bearing lubrication.
Always follow the specific lubrication instructions of your equipment supplier.

CYLINDRICAL ROLLER BEARINGS

Our product line includes full-complement, one-, two- and four-row designs, all developed to meet your application requirements. These bearings offer higher radial load capacity than other bearing types, and they effectively reduce friction and help transmit power.

- Nomenclature56
- One-Row Metric ISO Series...58
- One-Row Standard Series72
- Full-Complement (NCF)74
- Two-Row76
- Four-Row82
- HJ Series96
- Inner Rings (IR)..... 100
- 5200, A5200 Metric Series ...102

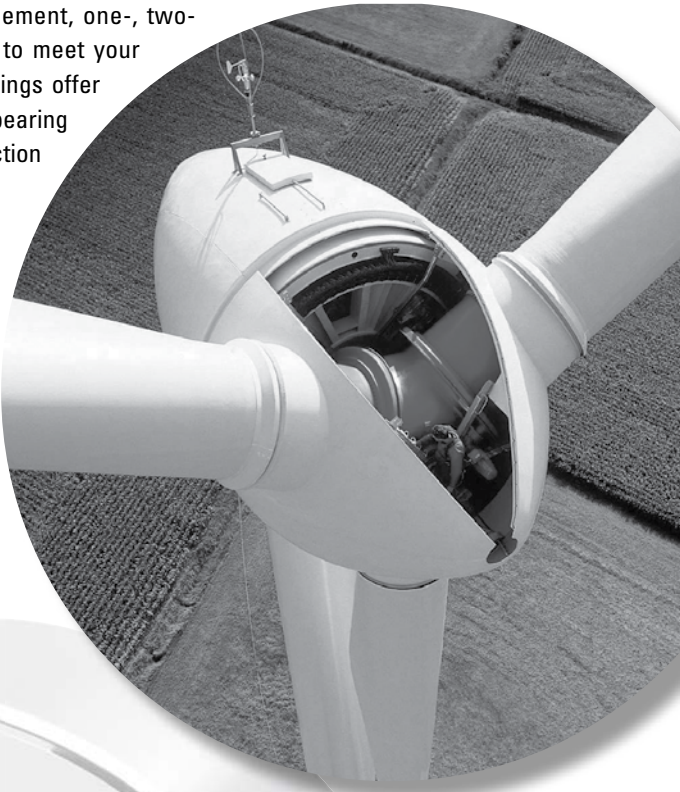

NOMENCLATURE

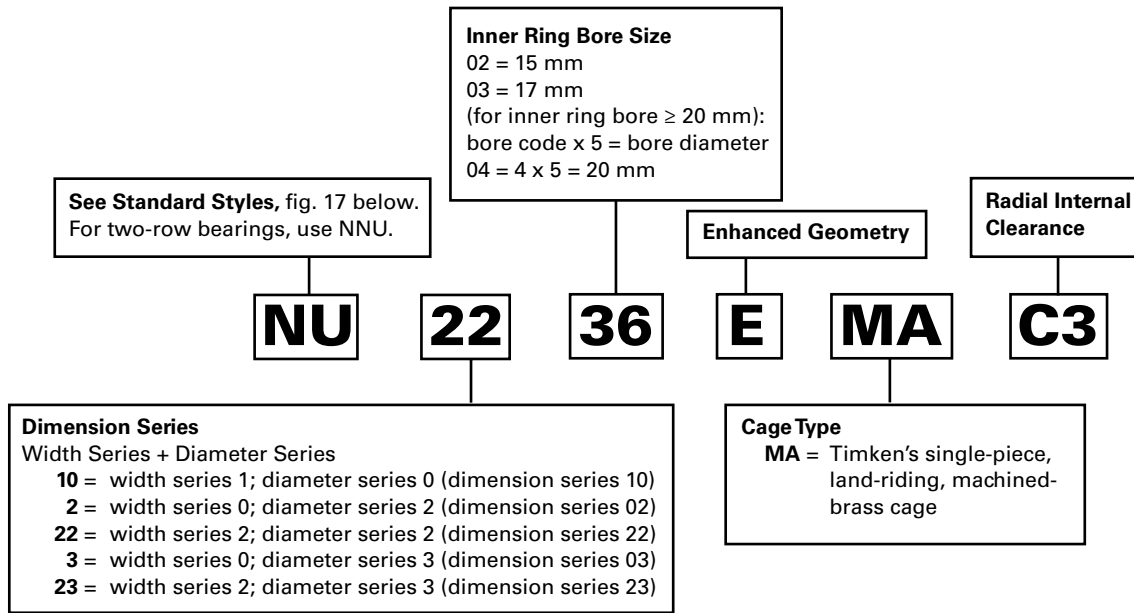

Fig. 16. Metric ISO radial cylindrical roller bearings nomenclature.

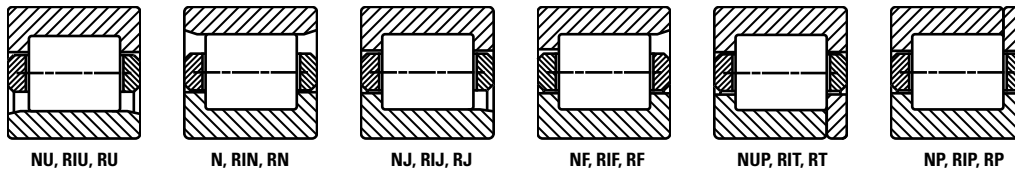

Fig. 17. Standard cylindrical roller bearing styles metric/inch.

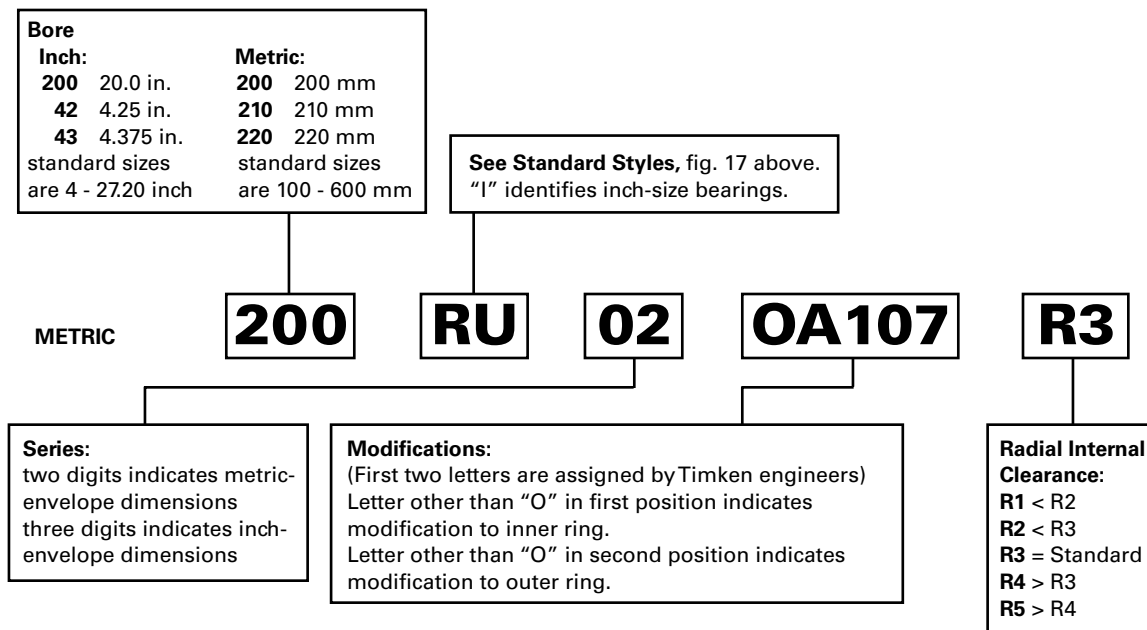

Fig. 18. ABMA radial cylindrical roller bearings nomenclature.

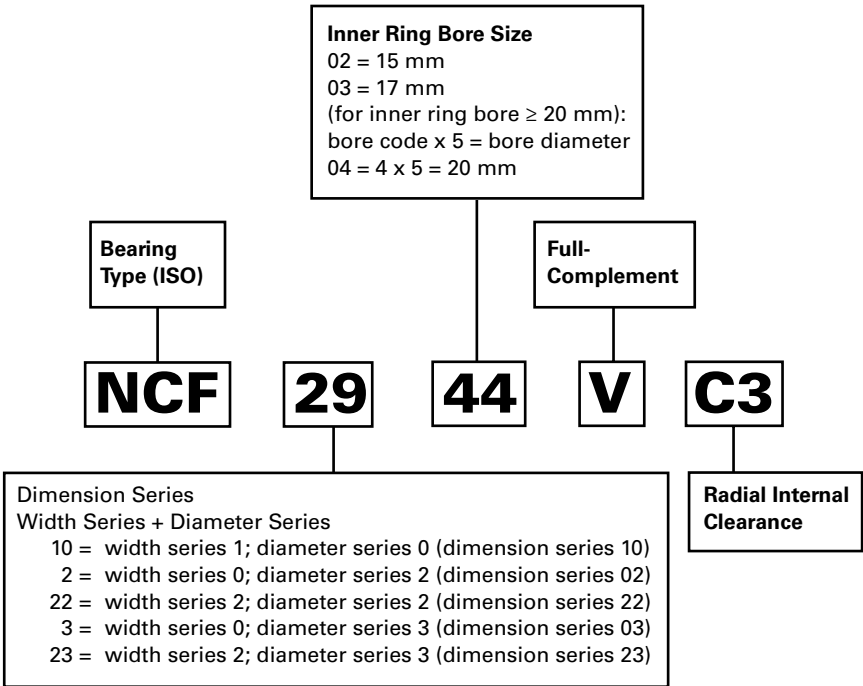

Fig. 19. Full-complement (NCF) cylindrical roller bearing nomenclature.

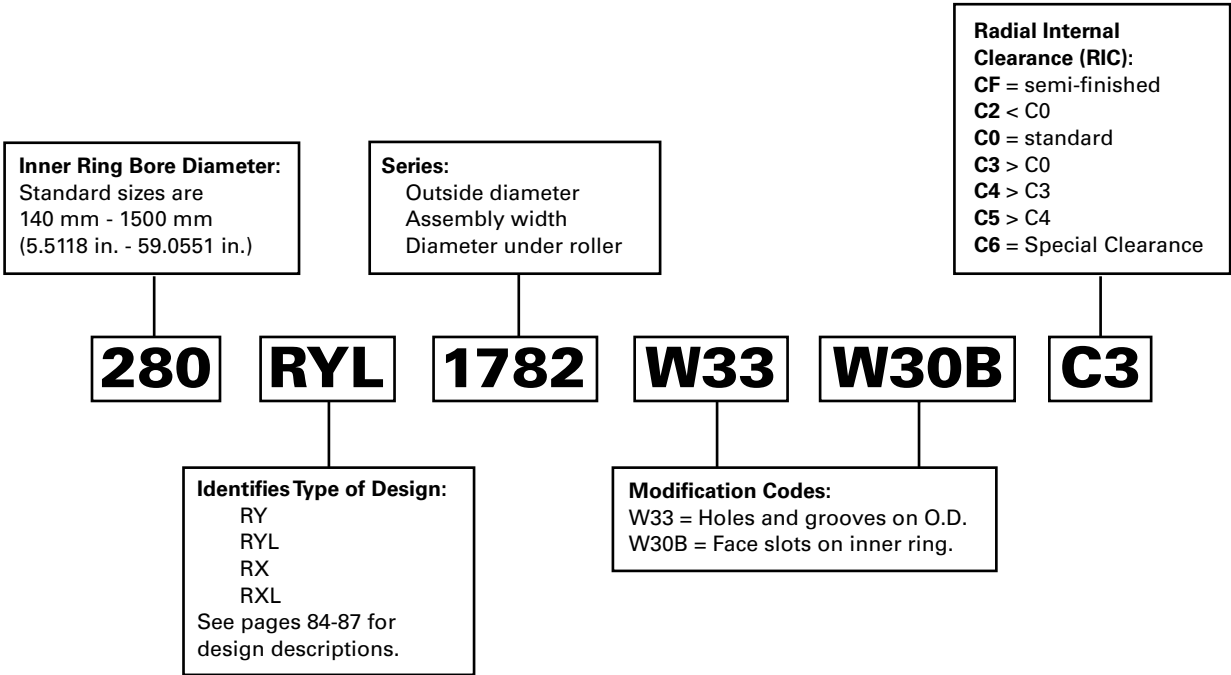
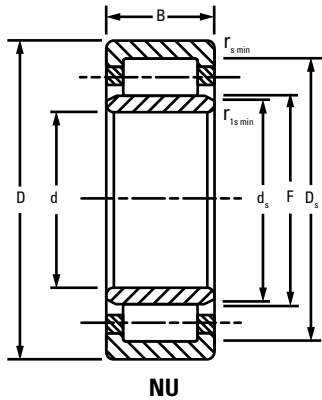
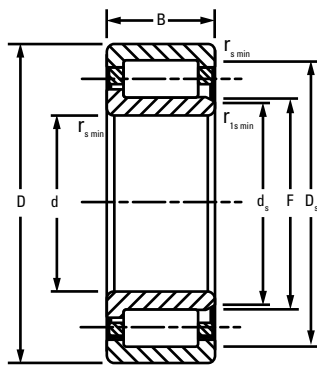

Fig. 20. Four-row cylindrical roller bearing nomenclature.

ONE-ROW METRIC ISO SERIES



NU



NJ

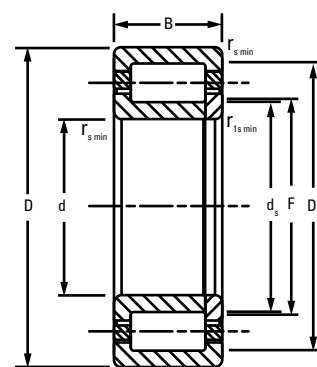

NUP

Bearing Dimensions				Load Rating		Bearing Part Number ⁽²⁾	Mounting Data				s ⁽³⁾	Geo- metry Factor C _g	Thermal Speed Ratings		Weight
Bore d	O.D. D	Width B	DUR/DOR F/E	Static C ₀	Dynamic C ₁ ⁽¹⁾		Chamfer		Backing Diameter				Oil	Grease	
mm in.	mm in.	mm in.	mm in.	kN lbf.	kN lbf.		r _{s min} mm in.	r _{1s min} mm in.	Shaft d _s mm in.	Housing D _s mm in.			RPM	RPM	
65.000 2.5591	140.000 5.5118	33.000 1.2992	82.500 3.2480	196 44100	204 45900	NU313EMA	2.1 0.08	2.1 0.08	78.2 3.08	124.5 4.90	2.5 0.10	0.075	4800	4100	2.50 5.40
65.000 2.5591	140.000 5.5118	48.000 1.8898	82.500 3.2480	293 65900	282 63300	NU2313EMA	2.1 0.08	2.1 0.08	77.1 3.04	124.5 4.90	4.0 0.16	0.082	4500	3900	3.60 8.00
70.000 2.7559	150.000 5.9055	51.000 2.0079	89.000 3.5039	328 73700	311 69800	NU2314EMA	2.1 0.08	2.1 0.08	83.3 3.28	133.0 5.24	4.7 0.19	0.087	4300	3700	4.40 9.80
75.000 2.9528	190.000 7.4803	45.000 1.7717	104.500 4.1142	305 68700	318 71500	NU415EMA	3.0 0.12	3.0 0.12	98.8 3.89	160.5 6.32	4.0 0.16	0.089	4400	3800	7.00 15.40
80.000 3.1496	140.000 5.5118	26.000 1.0236	95.300 3.7520	169 38000	155 34900	NU216EMA	2.0 0.08	2.0 0.08	92.4 3.64	127.3 5.01	1.7 0.07	0.079	4900	4100	1.80 3.63
80.000 3.1496	140.000 5.5118	33.000 1.2992	95.300 3.7520	245 55100	208 46800	NU2216EMA	2.0 0.08	2.0 0.08	91.3 3.59	127.3 5.01	1.7 0.07	0.086	3800	3300	2.20 4.80
80.000 3.1496	140.000 5.5118	33.000 1.2992	95.300 3.7520	245 55100	208 46800	NJ2216EMA	2.0 0.08	2.0 0.08	91.3 3.59	127.3 5.01	1.7 0.07	0.086	3800	3300	2.20 4.90
80.000 3.1496	140.000 5.5118	33.000 1.2992	95.300 3.7520	245 55100	208 46800	NUP2216EMA	2.0 0.08	2.0 0.08	95.3 3.75	127.3 5.01	- -	0.086	3800	3300	2.30 5.10
80.000 3.1496	170.000 6.6929	39.000 1.5354	101.000 3.9764	289 64900	290 65300	NU316EMA	2.1 0.08	2.1 0.08	96.5 3.80	151.0 5.94	2.4 0.09	0.088	4500	3900	4.60 10.12
80.000 3.1496	170.000 6.6929	58.000 2.2835	101.000 3.9764	439 98700	406 91300	NU2316EMA	2.1 0.08	2.1 0.08	95.4 3.76	151.0 5.94	5.0 0.20	0.097	3800	3300	6.00 12.50
85.000 3.3465	150.000 5.9055	28.000 1.1024	100.500 3.9567	201 45200	186 41900	NU217EMA	2.0 0.08	2.0 0.08	96.6 3.80	136.5 5.37	1.7 0.07	0.083	4600	3900	2.10 5.80
85.000 3.3465	150.000 5.9055	36.000 1.4173	100.500 3.9567	282 63300	244 54900	NU2217EMA	2.0 0.08	2.0 0.08	97.1 3.82	136.5 5.37	2.2 0.09	0.090	3600	3200	2.70 5.80
85.000 3.3465	180.000 7.0866	41.000 1.6142	108.000 4.2520	314 70600	313 70400	NU317EMA	3.0 0.12	3.0 0.12	103.6 4.08	160.0 6.30	3.5 0.14	0.092	4300	3700	5.10 11.22
85.000 3.3465	180.000 7.0866	60.000 2.3622	108.000 4.2520	458 103000	423 95200	NU2317EMA	3.0 0.12	3.0 0.12	101.8 4.01	160.0 6.30	5.5 0.22	0.100	3700	3200	7.40 16.40
85.000 3.3465	180.000 7.0866	60.000 2.3622	108.000 4.2520	458 103000	423 95200	NJ2317EMA	3.0 0.12	3.0 0.12	101.8 4.01	160.0 6.30	5.5 0.22	0.100	3700	3200	7.60 16.70

⁽¹⁾Based on 1 x 10⁶ revolutions L₁₀ life, for the ISO life calculation method.

⁽²⁾The radial internal clearance (RIC) for the bearing assembly must be included when ordering the complete assembly.

⁽³⁾Permissible axial displacement from normal position of one bearing ring in relation to the other.

Continued on next page.

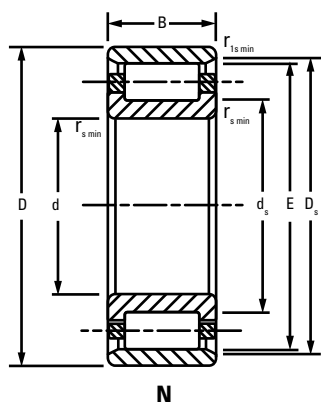

Bearing Dimensions				Load Rating		Bearing Part Number ⁽²⁾	Mounting Data				s ⁽³⁾	Geometry Factor C _g	Thermal Speed Ratings		Weight
Bore d	O.D. D	Width B	DUR/DOR F/E	Static C ₀	Dynamic C ₁ ⁽¹⁾		Chamfer		Backing Diameter				Oil	Grease	
mm in.	mm in.	mm in.	mm in.	kN lbf.	kN lbf.		r _{smin} mm in.	r _{1smin} mm in.	Shaft d _s mm in.	Housing D _s mm in.			RPM	RPM	
90.000 3.5433	160.000 6.2992	30.000 1.1811	107.000 4.2126	225 50500	206 46400	NU218EMA	2.0 0.08	2.0 0.08	103.6 4.08	145.0 5.71	2.7 0.11	0.087	4400	3700	2.60 5.80
90.000 3.5433	160.000 6.2992	30.000 1.1811	107.000 4.2126	225 50500	206 46400	NJ218EMA	2.0 0.08	2.0 0.08	103.6 4.08	145.0 5.71	2.7 0.11	0.087	4400	3700	2.70 5.90
90.000 3.5433	160.000 6.2992	40.000 1.5748	107.000 4.2126	322 72400	275 61900	NU2218EMA	2.0 0.08	2.0 0.08	103.0 4.06	145.0 5.71	3.2 0.12	0.094	3600	3100	3.50 7.70
90.000 3.5433	160.000 6.2992	40.000 1.5748	107.000 4.2126	322 72400	275 61900	NJ2218EMA	2.0 0.08	2.0 0.08	102.9 4.05	145.0 5.71	3.2 0.12	0.094	3600	3100	3.60 7.90
90.000 3.5433	160.000 6.2992	40.000 1.5748	107.000 4.2126	322 72400	275 61900	NUP2218EMA	2.0 0.08	2.0 0.08	102.9 4.05	145.0 5.71	- -	0.094	3600	3100	3.60 8.00
90.000 3.5433	190.000 7.4803	43.000 1.6929	113.500 4.4685	362 81500	359 80700	NU318EMA	3.0 0.12	3.0 0.12	107.9 4.25	169.5 6.67	2.5 0.10	0.096	4000	3500	6.10 13.40
90.000 3.5433	190.000 7.4803	43.000 1.6929	113.500 4.4685	362 81500	359 80700	NJ318EMA	3.0 0.12	3.0 0.12	107.9 4.25	169.5 6.67	2.5 0.10	0.096	4000	3500	6.20 13.60
90.000 3.5433	190.000 7.4803	64.000 2.5197	113.500 4.4685	544 122000	497 112000	NU2318EMA	3.0 0.12	3.0 0.12	106.8 4.20	169.5 6.67	5.0 0.20	0.106	3300	2900	9.10 20.00
90.000 3.5433	190.000 7.4803	64.000 2.5197	113.500 4.4685	544 122000	497 112000	NJ2318EMA	3.0 0.12	3.0 0.12	106.8 4.20	169.5 6.67	5.0 0.20	0.106	3300	2900	9.30 20.40
95.000 3.7402	170.000 6.6929	32.000 1.2598	112.500 4.4291	271 60900	248 55800	NU219EMA	2.1 0.08	2.1 0.08	109.1 4.30	154.5 6.08	1.8 0.07	0.092	4100	3500	3.10 6.90
95.000 3.7402	170.000 6.6929	32.000 1.2598	112.500 4.4291	271 60900	248 55800	NJ219EMA	2.1 0.08	2.1 0.08	109.1 4.30	154.5 6.08	1.8 0.07	0.092	4100	3500	3.20 7.00
95.000 3.7402	170.000 6.6929	43.000 1.6929	112.500 4.4291	378 84900	324 72800	NU2219EMA	2.1 0.08	2.1 0.08	108.1 4.26	154.5 6.08	3.5 0.14	0.099	3400	2900	4.20 9.30
95.000 3.7402	170.000 6.6929	43.000 1.6929	112.500 4.4291	378 84900	324 72800	NJ2219EMA	2.1 0.08	2.1 0.08	108.1 4.26	154.5 6.08	3.5 0.14	0.099	3400	2900	4.30 9.50
95.000 3.7402	200.000 7.8740	45.000 1.7717	121.500 4.7835	395 88900	379 85300	NU319EMA	3.0 0.12	3.0 0.12	115.3 4.54	177.5 6.99	3.0 0.12	0.101	3900	3400	7.10 15.70
95.000 3.7402	200.000 7.8740	45.000 1.7717	121.500 4.7835	395 88900	379 85300	NJ319EMA	3.0 0.12	3.0 0.12	115.3 4.54	177.5 6.99	3.0 0.12	0.101	3900	3400	7.30 16.00

⁽¹⁾Based on 1 x 10⁶ revolutions L₁₀ life, for the ISO life calculation method.

⁽²⁾The radial internal clearance (RIC) for the bearing assembly must be included when ordering the complete assembly.

⁽³⁾Permissible axial displacement from normal position of one bearing ring in relation to the other.

Continued on next page.

CYLINDRICAL ROLLER BEARINGS

ONE-ROW METRIC ISO SERIES

ONE-ROW METRIC ISO SERIES – continued

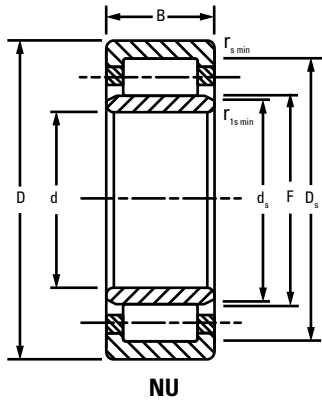

NU

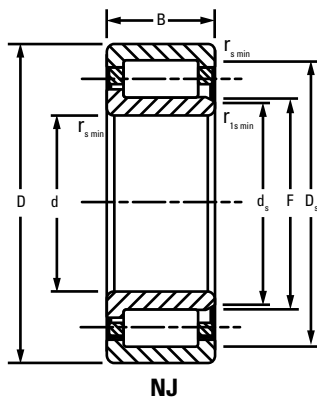

NJ

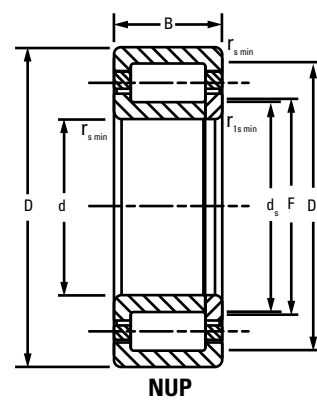

NUP

Bearing Dimensions				Load Rating		Bearing Part Number ⁽²⁾	Mounting Data				s ⁽³⁾	Geo-metry Factor C _g	Thermal Speed Ratings		Weight
Bore d	O.D. D	Width B	DUR/DOR F/E	Static C ₀	Dynamic C ₁ ⁽¹⁾		Chamfer		Backing Diameter				Oil	Grease	
mm in.	mm in.	mm in.	mm in.	kN lbf.	kN lbf.		r _{s min} mm in.	r _{1s min} mm in.	Shaft d _s mm in.	Housing D _s mm in.			RPM	RPM	
95.000 3.7402	200.000 7.8740	67.000 2.6378	121.500 4.7835	593 133000	525 118000	NU2319EMA	3.0 0.12	3.0 0.12	115.5 4.55	177.5 6.99	7.1 0.28	0.111	3100	2700	10.40 22.80
95.000 3.7402	200.000 7.8740	67.000 2.6378	121.500 4.7835	593 133000	525 118000	NJ2319EMA	3.0 0.12	3.0 0.12	115.5 4.55	177.5 6.99	7.1 0.28	0.111	3100	2700	10.60 23.30
100.000 3.9370	180.000 7.0866	34.000 1.3386	119.000 4.6850	311 70000	280 63000	NU220EMA	2.1 0.08	2.1 0.08	115.0 4.53	163.0 6.42	2.3 0.09	0.097	3900	3300	3.80 8.40
100.000 3.9370	180.000 7.0866	34.000 1.3386	119.000 4.6850	311 70000	280 63000	NJ220EMA	2.1 0.08	2.1 0.08	115.0 4.53	163.0 6.42	2.3 0.09	0.097	3900	3300	3.90 8.60
100.000 3.9370	180.000 7.0866	46.000 1.8110	119.000 4.6850	451 101000	377 84800	NU2220EMA	2.1 0.08	2.1 0.08	115.0 4.53	163.0 6.42	3.3 0.13	0.105	3100	2800	5.20 11.40
100.000 3.9370	180.000 7.0866	46.000 1.8110	119.000 4.6850	451 101000	377 84800	NJ2220EMA	2.1 0.08	2.1 0.08	115.0 4.53	163.0 6.42	3.3 0.13	0.105	3100	2800	5.30 11.60
100.000 3.9370	215.000 8.4646	47.000 1.8504	127.500 5.0197	442 99400	437 98200	NU320EMA	3.0 0.12	3.0 0.12	120.7 4.75	191.5 7.54	3.0 0.12	0.104	3600	3200	8.60 19.00
100.000 3.9370	215.000 8.4646	47.000 1.8504	127.500 5.0197	442 99400	437 98200	NJ320EMA	3.0 0.12	3.0 0.12	120.7 4.75	191.5 7.54	3.0 0.12	0.104	3600	3200	8.80 19.40
100.000 3.9370	215.000 8.4646	73.000 2.8740	127.500 5.0197	737 166000	658 148000	NU2320EMA	3.0 0.12	3.0 0.12	120.4 4.74	191.5 7.54	5.2 0.20	0.117	2700	2400	13.40 29.50
100.000 3.9370	215.000 8.4646	73.000 2.8740	127.500 5.0197	737 166000	658 148000	NJ2320EMA	3.0 0.12	3.0 0.12	120.4 4.74	191.5 7.54	5.2 0.20	0.117	2700	2400	13.70 30.10
110.000 4.3307	200.000 7.8740	38.000 1.4961	132.500 5.2165	374 84000	331 74400	NU222EMA	2.1 0.08	2.1 0.08	128.5 5.06	180.5 7.11	2.5 0.10	0.104	3600	3100	5.40 11.90
110.000 4.3307	200.000 7.8740	38.000 1.4961	132.500 5.2165	374 84000	331 74400	NJ222EMA	2.1 0.08	2.1 0.08	128.5 5.06	180.5 7.11	2.5 0.10	0.104	3600	3100	5.50 12.10
110.000 4.3307	200.000 7.8740	53.000 2.0866	132.500 5.2165	527 118000	436 98000	NU2222EMA	2.1 0.08	2.1 0.08	126.8 4.99	180.5 7.11	4.1 0.16	0.113	3000	2700	7.50 16.50
110.000 4.3307	200.000 7.8740	53.000 2.0866	132.500 5.2165	527 118000	436 98000	NJ2222EMA	2.1 0.08	2.1 0.08	126.8 4.99	180.5 7.11	4.1 0.16	0.113	3000	2700	7.60 16.80
110.000 4.3307	240.000 9.4488	50.000 1.9685	143.000 5.6299	546 123000	519 11700	NU322EMA	3.0 0.12	3.0 0.12	136.2 5.36	211.0 8.31	3.0 0.12	0.114	3100	2800	11.60 25.40

⁽¹⁾Based on 1 x 10⁶ revolutions L₁₀ life, for the ISO life calculation method.

⁽²⁾The radial internal clearance (RIC) for the bearing assembly must be included when ordering the complete assembly.

⁽³⁾Permissible axial displacement from normal position of one bearing ring in relation to the other.

Continued on next page.

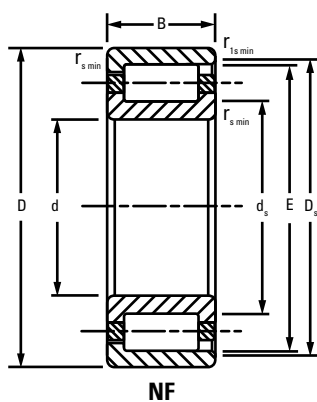
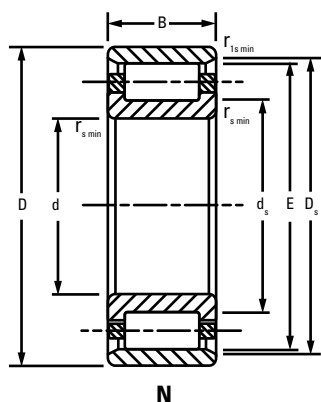

Bearing Dimensions				Load Rating		Bearing Part Number ⁽²⁾	Mounting Data				s ⁽³⁾	Geo-metry Factor C _g	Thermal Speed Ratings		Weight
Bore d	O.D. D	Width B	DUR/DOR F/E	Static C ₀	Dynamic C ₁ ⁽¹⁾		Chamfer		Backing Diameter				Oil	Grease	
mm in.	mm in.	mm in.	mm in.	kN lbf.	kN lbf.		r _{smin} mm in.	r _{1smin} mm in.	Shaft d _s mm in.	Housing D _s mm in.			RPM	RPM	
110.000 4.3307	240.000 9.4488	50.000 1.9685	143.000 5.6299	546 123000	519 11700	NJ322EMA	3.0 0.12	3.0 0.12	136.2 5.36	211.0 8.31	3.0 0.12	0.114	3100	2800	11.80 25.90
110.000 4.3307	240.000 9.4488	80.000 3.1496	143.000 5.6299	891 200000	768 173000	NU2322EMA	3.0 0.12	3.0 0.12	134.6 5.30	211.0 8.31	6.4 0.25	0.128	2400	2100	18.60 40.90
110.000 4.3307	240.000 9.4488	80.000 3.1496	143.000 5.6299	891 200000	768 173000	NJ2322EMA	3.0 0.12	3.0 0.12	134.6 5.30	211.0 8.31	6.4 0.25	0.128	2400	2100	19.20 42.10
120.000 4.7244	180.000 7.0866	28.000 1.1024	135.000 5.3150	202 45300	158 35600	NU1024MA	2.0 0.08	1.1 0.04	131.2 5.17	165.0 6.50	3.8 0.15	0.096	3600	2900	2.60 5.60
120.000 4.7244	215.000 8.4646	40.000 1.5748	143.500 5.6496	431 97000	379 85300	NU224EMA	2.1 0.08	2.1 0.08	138.0 5.43	195.5 7.70	2.1 0.08	0.111	3400	2900	6.50 14.30
120.000 4.7244	215.000 8.4646	40.000 1.5748	143.500 5.6496	431 97000	379 85300	NJ224EMA	2.1 0.08	2.1 0.08	138.0 5.43	195.5 7.70	2.1 0.08	0.111	3400	2900	6.60 14.50
120.000 4.7244	215.000 8.4646	58.000 2.2835	143.500 5.6496	630 142000	514 116000	NU2224EMA	2.1 0.08	2.1 0.08	137.4 5.41	195.5 7.70	4.6 0.18	0.121	2700	2400	9.40 20.80
120.000 4.7244	215.000 8.4646	58.000 2.2835	143.500 5.6496	630 142000	514 116000	NJ2224EMA	2.1 0.08	2.1 0.08	137.4 5.41	195.5 7.70	4.6 0.18	0.121	2700	2400	9.60 21.20
120.000 4.7244	260.000 10.2362	55.000 2.1654	154.000 6.0630	614 138000	594 134000	NU324EMA	3.0 0.12	3.0 0.12	147.0 5.79	230.0 9.06	3.8 0.15	0.120	2900	2500	14.70 32.30
120.000 4.7244	260.000 10.2362	55.000 2.1654	154.000 6.0630	614 138000	594 134000	NJ324EMA	3.0 0.12	3.0 0.12	147.0 5.79	230.0 9.06	3.8 0.15	0.120	2900	2500	15.00 32.90
120.000 4.7244	260.000 10.2362	86.000 3.3858	154.000 6.0630	1040 233000	902 203000	NU2324EMA	3.0 0.12	3.0 0.12	145.9 5.74	230.0 9.06	6.3 0.25	0.136	2100	1900	23.10 50.90
120.000 4.7244	260.000 10.2362	86.000 3.3858	154.000 6.0630	1040 233000	902 203000	NJ2324EMA	3.0 0.12	3.0 0.12	145.9 5.74	230.0 9.06	6.3 0.25	0.136	2100	1900	23.60 52.00
130.000 5.1181	200.000 7.8740	33.000 1.2992	148.000 5.8268	251 56500	197 44300	NU1026MA	2.0 0.08	1.1 0.04	142.6 5.61	182.0 7.17	2.2 0.09	0.104	3500	2900	7.20 15.80
130.000 5.1181	230.000 9.0551	40.000 1.5748	153.500 6.0433	464 104000	411 92300	NU226EMA	3.0 0.12	3.0 0.12	148.0 5.83	209.5 8.25	2.2 0.09	0.115	3100	2700	7.20 15.80
130.000 5.1181	230.000 9.0551	40.000 1.5748	153.500 6.0433	464 104000	411 92300	NJ226EMA	3.0 0.12	3.0 0.12	148.0 5.83	209.5 8.25	2.2 0.09	0.115	3100	2700	7.30 16.10

⁽¹⁾Based on 1 x 10⁶ revolutions L₁₀ life, for the ISO life calculation method.

⁽²⁾The radial internal clearance (RIC) for the bearing assembly must be included when ordering the complete assembly.

⁽³⁾Permissible axial displacement from normal position of one bearing ring in relation to the other.

Continued on next page.

CYLINDRICAL ROLLER BEARINGS

ONE-ROW METRIC ISO SERIES

ONE-ROW METRIC ISO SERIES – continued

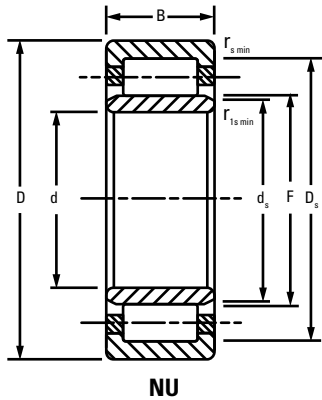

NU

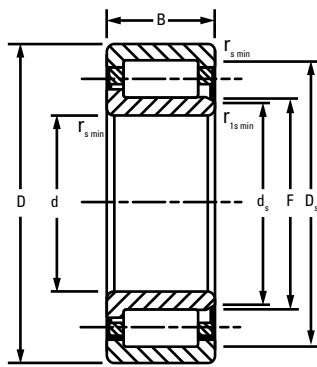

NJ

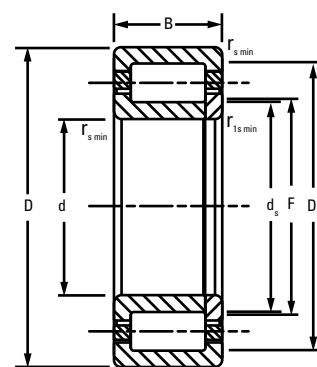

NUP

Bearing Dimensions				Load Rating		Bearing Part Number ⁽²⁾	Mounting Data				s ⁽³⁾	Geo-metry Factor C _g	Thermal Speed Ratings		Weight
Bore d	O.D. D	Width B	DUR/DOR F/E	Static C ₀	Dynamic C ₁ ⁽¹⁾		Chamfer		Backing Diameter				Oil	Grease	
mm in.	mm in.	mm in.	mm in.	kN lbf.	kN lbf.		r _{s min} mm in.	r _{1s min} mm in.	Shaft d _s mm in.	Housing D _s mm in.			RPM	RPM	
130.000 5.1181	230.000 9.0551	64.000 2.5197	153.500 6.0433	750 169000	603 135000	NU2226EMA	3.0 0.12	3.0 0.12	146.8 5.78	209.5 8.25	5.0 0.20	0.129	2400	2200	11.50 25.40
130.000 5.1181	230.000 9.0551	64.000 2.5197	153.500 6.0433	750 169000	603 135000	NJ2226EMA	3.0 0.12	3.0 0.12	146.8 5.78	209.5 8.25	5.0 0.20	0.129	2400	2200	11.80 25.90
130.000 5.1181	280.000 11.0236	58.000 2.2835	167.000 6.5748	753 169000	701 158000	NU326EMA	4.0 0.16	4.0 0.16	159.7 6.29	247.0 9.72	3.7 0.14	0.108	2500	2200	18.10 39.70
130.000 5.1181	280.000 11.0236	58.000 2.2835	167.000 6.5748	753 169000	701 158000	NJ326EMA	4.0 0.16	4.0 0.16	159.7 6.29	247.0 9.72	3.7 0.14	0.108	2500	2200	18.50 40.70
130.000 5.1181	280.000 11.0236	93.000 3.6614	167.000 6.5748	1240 278000	1040 235000	NU2326EMA	4.0 0.16	4.0 0.16	158.1 6.22	247.0 9.72	7.6 0.30	0.122	1900	1700	29.30 64.40
130.000 5.1181	280.000 11.0236	93.000 3.6614	167.000 6.5748	1240 278000	1040 235000	NJ2326EMA	4.0 0.16	4.0 0.16	158.1 6.22	247.0 9.72	7.6 0.30	0.122	1900	1700	29.80 65.50
140.000 5.5118	210.000 8.2677	33.000 1.2992	158.000 6.2205	263 59200	201 45200	NU1028MA	2.0 0.08	1.1 0.04	152.9 6.02	192.0 7.56	3.8 0.15	0.108	3300	2700	4.00 8.90
140.000 5.5118	250.000 9.8425	42.000 1.6535	169.000 6.6535	526 118000	443 99500	NU228EMA	3.0 0.12	3.0 0.12	162.4 6.39	225.0 8.86	2.1 0.08	0.124	2900	2500	9.20 20.30
140.000 5.5118	250.000 9.8425	42.000 1.6535	169.000 6.6535	526 118000	443 99500	NJ228EMA	3.0 0.12	3.0 0.12	162.4 6.39	225.0 8.86	2.1 0.08	0.124	2900	2500	9.40 20.70
140.000 5.5118	250.000 9.8425	68.000 2.6772	169.000 6.6535	850 191000	650 146000	NU2228EMA	3.0 0.12	3.0 0.12	160.1 6.30	225.0 8.86	5.0 0.20	0.138	2200	2000	14.80 32.50
140.000 5.5118	250.000 9.8425	68.000 2.6772	169.000 6.6535	850 191000	650 146000	NJ2228EMA	3.0 0.12	3.0 0.12	160.1 6.30	225.0 8.86	5.0 0.20	0.138	2200	2000	15.10 33.20
140.000 5.5118	300.000 11.8110	62.000 2.4409	180.000 7.0866	837 188000	771 173000	NU328EMA	4.0 0.16	4.0 0.16	174.2 6.86	264.0 10.39	5.2 0.20	0.114	2300	2000	22.10 48.50
140.000 5.5118	300.000 11.8110	62.000 2.4409	180.000 7.0866	837 188000	771 173000	NJ328EMA	4.0 0.16	4.0 0.16	174.2 6.86	264.0 10.39	5.2 0.20	0.114	2300	2000	22.50 49.50
140.000 5.5118	300.000 11.8110	102.000 4.0157	180.000 7.0866	1420 319000	1180 265000	NU2328EMA	4.0 0.16	4.0 0.16	171.3 6.74	264.0 10.39	9.7 0.38	0.129	1700	1500	36.10 79.40
140.000 5.5118	300.000 11.8110	102.000 4.0157	180.000 7.0866	1420 319000	1180 265000	NJ2328EMA	4.0 0.16	4.0 0.16	171.3 6.74	264.0 10.39	9.7 0.38	0.129	1700	1500	36.80 81.00

⁽¹⁾Based on 1 x 10⁶ revolutions L₁₀ life, for the ISO life calculation method.

⁽²⁾The radial internal clearance (RIC) for the bearing assembly must be included when ordering the complete assembly.

⁽³⁾Permissible axial displacement from normal position of one bearing ring in relation to the other.

Continued on next page.

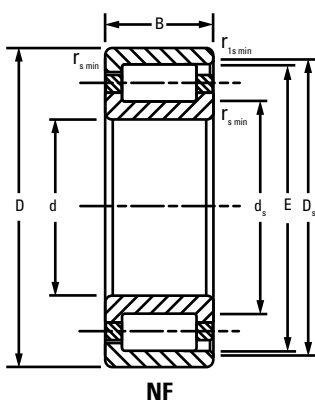
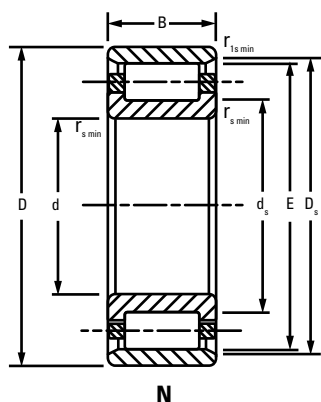

Bearing Dimensions				Load Rating		Bearing Part Number ⁽²⁾	Mounting Data				s ⁽³⁾	Geometry Factor C _g	Thermal Speed Ratings		Weight
Bore d	O.D. D	Width B	DUR/DOR F/E	Static C ₀	Dynamic C ₁ ⁽¹⁾		Chamfer		Backing Diameter				Oil	Grease	
mm in.	mm in.	mm in.	mm in.	kN lbf.	kN lbf.		r _{smin} mm in.	r _{1smin} mm in.	Shaft d _s mm in.	Housing D _s mm in.					
150.000 5.9055	225.000 8.8583	35.000 1.3780	169.500 6.6732	309 69500	231 51900	NU1030MA	2.1 0.08	1.5 0.06	164.6 6.48	205.5 8.09	4.9 0.19	0.115	3100	2500	4.90 10.80
150.000 5.9055	270.000 10.6299	45.000 1.7717	182.000 7.1654	607 137000	506 114000	NU230EMA	3.0 0.12	3.0 0.12	176.9 6.96	242.0 9.53	4.0 0.16	0.109	2600	2300	11.60 25.60
150.000 5.9055	270.000 10.6299	45.000 1.7717	182.000 7.1654	607 137000	506 114000	NJ230EMA	3.0 0.12	3.0 0.12	176.9 6.96	242.0 9.53	4.0 0.16	0.109	2600	2300	12.00 26.30
150.000 5.9055	270.000 10.6299	45.000 1.7717	182.000 7.1654	607 137000	506 114000	NUP230EMA	3.0 0.12	3.0 0.12	176.9 6.96	242.0 9.53	– –	0.109	2600	2300	12.10 26.60
150.000 5.9055	270.000 10.6299	73.000 2.8740	182.000 7.1654	998 224000	752 169000	NU2230EMA	3.0 0.12	3.0 0.12	173.5 6.83	242.0 9.53	6.0 0.24	0.123	2000	1800	18.60 40.90
150.000 5.9055	270.000 10.6299	73.000 2.8740	182.000 7.1654	998 224000	752 169000	NJ2230EMA	3.0 0.12	3.0 0.12	173.5 6.83	242.0 9.53	6.0 0.24	0.123	2000	1800	18.90 41.36
150.000 5.9055	270.000 10.6299	73.000 2.8740	242.000 9.5276	998 224000	752 169000	N2230EMB	3.0 0.12	3.0 0.12	182.0 7.17	250.5 9.86	6.0 0.24	0.123	2000	1800	18.40 40.40
150.000 5.9055	320.000 12.5984	65.000 2.5591	193.000 7.5984	951 214000	870 196000	NU330EMA	4.0 0.16	4.0 0.16	185.7 7.31	283.0 11.14	4.0 0.16	0.120	2100	1900	26.20 57.70
150.000 5.9055	320.000 12.5984	65.000 2.5591	193.000 7.5984	951 214000	870 196000	NJ330EMA	4.0 0.16	4.0 0.16	185.7 7.31	283.0 11.14	4.0 0.16	0.120	2100	1900	26.70 58.80
150.000 5.9055	320.000 12.5984	108.000 4.2520	193.000 7.5984	1620 364000	1330 299000	NU2330EMA	4.0 0.16	4.0 0.16	182.7 7.19	283.0 11.14	9.0 0.35	0.136	1600	1400	43.60 95.80
150.000 5.9055	320.000 12.5984	108.000 4.2520	193.000 7.5984	1620 364000	1330 299000	NJ2330EMA	4.0 0.16	4.0 0.16	182.7 7.19	283.0 11.14	9.0 0.35	0.136	1600	1400	44.40 97.70
160.000 6.2992	240.000 9.4488	38.000 1.4961	180.000 7.0866	367 82500	276 62000	NU1032MA	2.1 0.08	1.5 0.06	173.9 6.85	220.0 8.66	4.4 0.17	0.121	3000	2400	5.90 13.00
160.000 6.2992	290.000 11.4173	48.000 1.8898	195.000 7.6772	695 156000	572 129000	NU232EMA	3.0 0.12	3.0 0.12	189.6 7.46	259.0 10.20	4.2 0.17	0.115	2400	2100	14.50 31.80
160.000 6.2992	290.000 11.4173	48.000 1.8898	195.000 7.6772	695 156000	572 129000	NJ232EMA	3.0 0.12	3.0 0.12	189.6 7.46	259.0 10.20	4.2 0.17	0.115	2400	2100	14.70 32.40
160.000 6.2992	290.000 11.4173	48.000 1.8898	195.000 7.6772	695 156000	572 129000	NUP232EMA	3.0 0.12	3.0 0.12	189.6 7.46	259.0 10.20	– –	0.115	2400	2100	15.00 33.00

⁽¹⁾Based on 1 x 10⁶ revolutions L₁₀ life, for the ISO life calculation method.

⁽²⁾The radial internal clearance (RIC) for the bearing assembly must be included when ordering the complete assembly.

⁽³⁾Permissible axial displacement from normal position of one bearing ring in relation to the other.

Continued on next page.

CYLINDRICAL ROLLER BEARINGS

ONE-ROW METRIC ISO SERIES

ONE-ROW METRIC ISO SERIES – continued

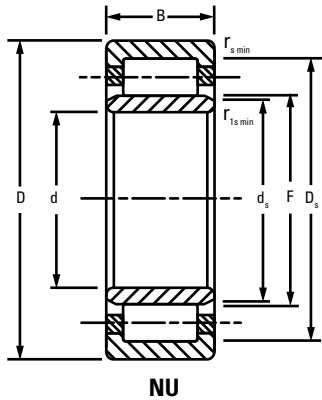

NU

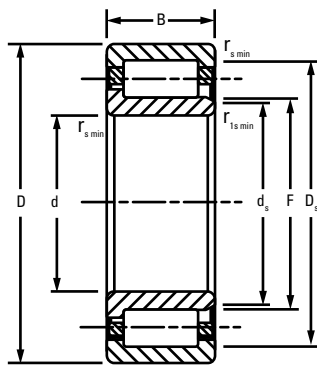

NJ

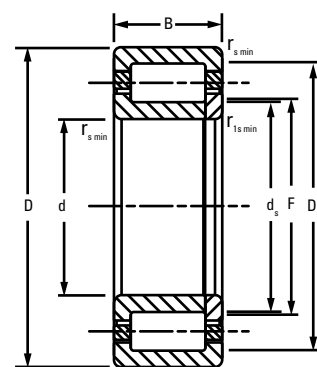

NUP

Bearing Dimensions				Load Rating		Bearing Part Number ⁽²⁾	Mounting Data				s ⁽³⁾	Geo-metry Factor C _g	Thermal Speed Ratings		Weight
Bore d	O.D. D	Width B	DUR/DOR F/E	Static C ₀	Dynamic C ₁ ⁽¹⁾		Chamfer		Backing Diameter				Oil	Grease	
mm in.	mm in.	mm in.	mm in.	kN lbf.	kN lbf.		r _{s min} mm in.	r _{1s min} mm in.	Shaft d _s mm in.	Housing D _s mm in.			RPM	RPM	
160.000 6.2992	290.000 11.4173	80.000 3.1496	193.000 7.5984	1210 271000	919 207000	NU2232EMA	3.0 0.12	3.0 0.12	183.6 7.23	261.0 10.28	4.5 0.18	0.130	1700	1600	23.80 52.40
160.000 6.2992	290.000 11.4173	80.000 3.1496	193.000 7.5984	1210 271000	919 207000	NJ2232EMA	3.0 0.12	3.0 0.12	183.6 7.23	261.0 10.28	4.5 0.18	0.130	1700	1600	24.30 53.50
160.000 6.2992	340.000 13.3858	68.000 2.6772	204.000 8.0315	1090 244000	985 221000	NU332EMA	4.0 0.16	4.0 0.16	197.3 7.77	300.0 11.81	5.5 0.22	0.126	1900	1700	31.10 68.40
160.000 6.2992	340.000 13.3858	68.000 2.6772	204.000 8.0315	1090 244000	985 221000	NJ332EMA	4.0 0.16	4.0 0.16	197.3 7.77	300.0 11.81	5.5 0.22	0.126	1900	1700	31.60 69.50
160.000 6.2992	340.000 13.3858	114.000 4.4882	204.000 8.0315	1840 413000	1500 337000	NU2332EMA	4.0 0.16	4.0 0.16	194.0 7.64	300.0 11.81	10.0 0.39	0.143	1400	1300	52.20 114.80
160.000 6.2992	340.000 13.3858	114.000 4.4882	204.000 8.0315	1840 413000	1500 337000	NJ2332EMA	4.0 0.16	4.0 0.16	194.0 7.64	300.0 11.81	10.0 0.39	0.143	1400	1300	53.10 116.80
170.000 6.6929	260.000 10.2362	42.000 1.6535	193.000 7.5984	425 95600	321 72200	NU1034MA	2.1 0.08	2.1 0.08	186.3 7.33	237.0 9.33	4.9 0.19	0.107	2800	2300	8.00 17.70
170.000 6.6929	260.000 10.2362	67.000 2.6378	191.000 7.5197	1080 243000	722 162000	NU3034EMA	2.1 0.08	2.1 0.08	185.2 7.29	241.0 9.49	4.4 0.17	0.131	1500	1300	8.00 17.70
170.000 6.6929	310.000 12.2047	52.000 2.0472	207.000 8.1496	822 185000	685 154000	NU234EMA	4.0 0.16	4.0 0.16	201.6 7.94	279.0 10.98	4.4 0.17	0.122	2200	1900	17.60 38.70
170.000 6.6929	310.000 12.2047	52.000 2.0472	207.000 8.1496	822 185000	685 154000	NJ234EMA	4.0 0.16	4.0 0.16	201.6 7.94	279.0 10.98	4.4 0.17	0.122	2200	1900	17.90 39.40
170.000 6.6929	310.000 12.2047	86.000 3.3858	205.000 8.0709	1420 320000	1100 246000	NU2234EMA	4.0 0.16	4.0 0.16	196.9 7.75	281.0 11.06	4.5 0.18	0.138	1600	1400	28.70 63.20
170.000 6.6929	310.000 12.2047	86.000 3.3858	205.000 8.0709	1420 320000	1100 246000	NJ2234EMA	4.0 0.16	4.0 0.16	196.9 7.75	281.0 11.06	4.5 0.18	0.138	1600	1400	29.30 64.50
170.000 6.6929	360.000 14.1732	72.000 2.8346	218.000 8.5827	1160 261000	1050 236000	NU334EMA	4.0 0.16	4.0 0.16	210.5 8.29	318.0 12.52	6.4 0.25	0.131	1800	1600	36.90 81.18
170.000 6.6929	360.000 14.1732	72.000 2.8346	218.000 8.5827	1160 261000	1050 236000	NJ334EMA	4.0 0.16	4.0 0.16	210.5 8.29	318.0 12.52	6.4 0.25	0.131	1800	1600	37.50 82.50
170.000 6.6929	360.000 14.1732	120.000 4.7244	216.000 8.5039	2110 474000	1710 385000	NU2334EMA	4.0 0.16	4.0 0.16	205.7 8.10	320.0 12.60	10.3 0.41	0.150	1300	1200	61.90 136.20

⁽¹⁾Based on 1 x 10⁶ revolutions L₁₀ life, for the ISO life calculation method.

⁽²⁾The radial internal clearance (RIC) for the bearing assembly must be included when ordering the complete assembly.

⁽³⁾Permissible axial displacement from normal position of one bearing ring in relation to the other.

Continued on next page.

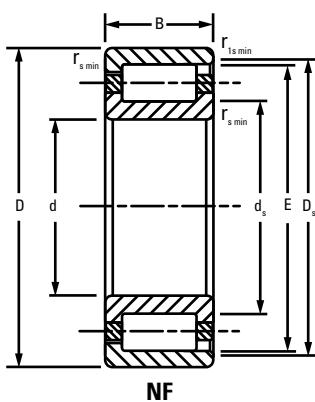
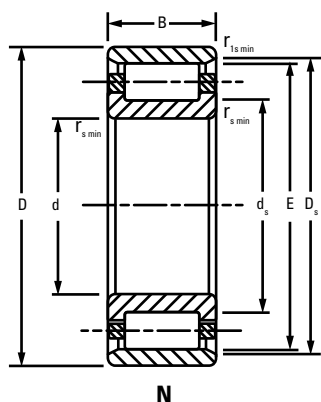

Bearing Dimensions				Load Rating		Bearing Part Number ⁽²⁾	Mounting Data				s ⁽³⁾	Geo-metry Factor C _g	Thermal Speed Ratings		Weight
Bore d	O.D. D	Width B	DUR/DOR F/E	Static C ₀	Dynamic C ₁ ⁽¹⁾		Chamfer		Backing Diameter				Oil	Grease	
mm in.	mm in.	mm in.	mm in.	kN lbf.	kN lbf.		r _{smin}	r _{1smin}	Shaft d _s	Housing D _s					
170.000 6.6929	360.000 14.1732	120.000 4.7244	216.000 8.5039	2110 474000	1710 385000	NJ2334EMA	4.0 0.16	4.0 0.16	205.7 8.10	320.0 12.60	10.3 0.41	0.150	1300	1200	63.00 138.50
180.000 7.0866	280.000 11.0236	46.000 1.8110	205.000 8.0709	500 112000	386 86800	NU1036MA	2.1 0.08	2.1 0.08	198.9 7.83	255.0 10.04	6.1 0.24	0.112	2600	2100	10.30 22.80
180.000 7.0866	320.000 12.5984	52.000 2.0472	217.000 8.5433	874 196000	711 160000	NU236EMA	4.0 0.16	4.0 0.16	211.6 8.33	289.0 11.38	4.4 0.17	0.126	2000	1800	18.30 40.40
180.000 7.0866	320.000 12.5984	52.000 2.0472	217.000 8.5433	874 196000	711 160000	NJ236EMA	4.0 0.16	4.0 0.16	211.6 8.33	289.0 11.38	4.4 0.17	0.126	2000	1800	18.70 41.10
180.000 7.0866	320.000 12.5984	86.000 3.3858	215.000 8.4646	1520 342000	1140 256000	NU2236EMA	4.0 0.16	4.0 0.16	206.0 8.11	291.0 11.46	5.5 0.22	0.143	1400	1300	30.60 67.32
180.000 7.0866	320.000 12.5984	86.000 3.3858	215.000 8.4646	1520 342000	1140 256000	NJ2236EMA	4.0 0.16	4.0 0.16	206.0 8.11	291.0 11.46	5.5 0.22	0.143	1400	1300	31.20 68.60
180.000 7.0866	380.000 14.9606	75.000 2.9528	231.000 9.0945	1290 290000	1150 258000	NU336EMA	4.0 0.16	4.0 0.16	223.2 8.79	335.0 13.19	6.5 0.26	0.137	1600	1500	42.60 93.60
180.000 7.0866	380.000 14.9606	75.000 2.9528	231.000 9.0945	1290 290000	1150 258000	NJ336EMA	4.0 0.16	4.0 0.16	223.2 8.79	335.0 13.19	6.5 0.26	0.137	1600	1500	43.40 95.50
180.000 7.0866	380.000 14.9606	126.000 4.9606	227.000 8.9370	2250 506000	1860 419000	NU2336EMA	4.0 0.16	4.0 0.16	215.7 8.49	339.0 13.35	8.7 0.34	0.154	1200	1100	70.90 155.90
180.000 7.0866	380.000 14.9606	126.000 4.9606	227.000 8.9370	2250 506000	1860 419000	NJ2336EMA	4.0 0.16	4.0 0.16	215.7 8.49	339.0 13.35	8.7 0.34	0.154	1200	1100	72.10 158.70
190.000 7.4803	290.000 11.4173	46.000 1.8110	215.000 8.4646	525 118000	396 89100	NU1038MA	2.1 0.08	2.1 0.08	207.9 8.19	265.0 10.43	6.1 0.24	0.116	2400	2000	10.70 23.50
190.000 7.4803	340.000 13.3858	55.000 2.1654	230.000 9.0551	960 216000	777 175000	NU238EMA	4.0 0.16	4.0 0.16	224.2 8.83	306.0 12.05	4.5 0.18	0.132	1900	1600	22.20 48.80
190.000 7.4803	340.000 13.3858	55.000 2.1654	230.000 9.0551	960 216000	777 175000	NJ238EMA	4.0 0.16	4.0 0.16	224.2 8.83	306.0 12.05	4.5 0.18	0.132	1900	1600	22.60 49.60
190.000 7.4803	340.000 13.3858	92.000 3.6220	228.000 8.9764	1680 377000	1250 281000	NU2238EMA	4.0 0.16	4.0 0.16	219.0 8.62	308.0 12.13	7.0 0.28	0.149	1300	1200	39.00 85.80
190.000 7.4803	340.000 13.3858	92.000 3.6220	228.000 8.9764	1680 377000	1250 281000	NJ2238EMA	4.0 0.16	4.0 0.16	219.0 8.62	308.0 12.13	7.0 0.28	0.149	1300	1200	37.80 83.20

⁽¹⁾Based on 1 x 10⁶ revolutions L₁₀ life, for the ISO life calculation method.

⁽²⁾The radial internal clearance (RIC) for the bearing assembly must be included when ordering the complete assembly.

⁽³⁾Permissible axial displacement from normal position of one bearing ring in relation to the other.

Continued on next page.

CYLINDRICAL ROLLER BEARINGS

ONE-ROW METRIC ISO SERIES

ONE-ROW METRIC ISO SERIES – continued

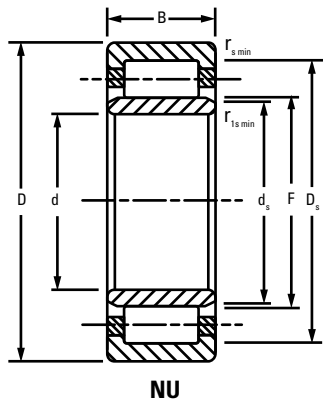

NU

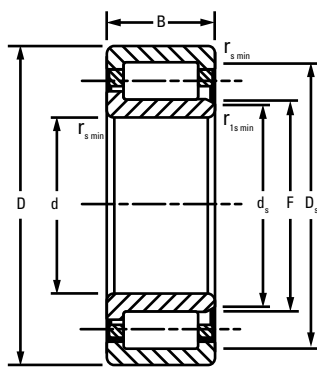

NJ

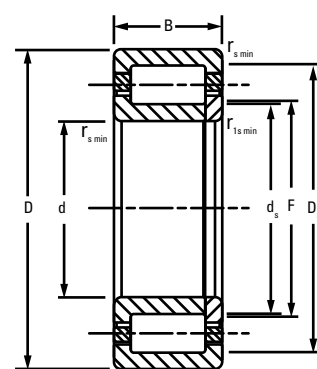

NUP

Bearing Dimensions				Load Rating		Bearing Part Number ⁽²⁾	Mounting Data				s ⁽³⁾	Geo-metry Factor C _g	Thermal Speed Ratings		Weight
Bore d	O.D. D	Width B	DUR/DOR F/E	Static C ₀	Dynamic C ₁ ⁽¹⁾		Chamfer		Backing Diameter				Oil	Grease	
mm in.	mm in.	mm in.	mm in.	kN lbf.	kN lbf.		r _{s min} mm in.	r _{1s min} mm in.	Shaft d _s mm in.	Housing D _s mm in.			RPM	RPM	
190.000 7.4803	400.000 15.7480	78.000 3.0709	245.000 9.6457	1500 337000	1300 292000	NU338EMA	5.0 0.20	5.0 0.20	236.5 9.31	353.0 13.90	6.0 0.24	0.145	1500	1300	49.40 108.70
190.000 7.4803	400.000 15.7480	78.000 3.0709	245.000 9.6457	1500 337000	1300 292000	NJ338EMA	5.0 0.20	5.0 0.20	236.5 9.31	353.0 13.90	6.0 0.24	0.145	1500	1300	50.20 110.50
190.000 7.4803	400.000 15.7480	132.000 5.1969	240.000 9.4488	2500 561000	2060 464000	NU2338EMA	5.0 0.20	5.0 0.20	227.6 8.96	360.0 14.17	9.8 0.39	0.161	1100	1000	80.30 176.60
190.000 7.4803	400.000 15.7480	132.000 5.1969	240.000 9.4488	2500 561000	2060 464000	NJ2338EMA	5.0 0.20	5.0 0.20	227.6 8.96	360.0 14.17	9.8 0.39	0.161	1100	1000	81.80 179.90
200.000 7.8740	310.000 12.2047	51.000 2.0079	229.000 9.0157	596 134000	440 98800	NU1040MA	2.1 0.08	2.1 0.08	221.1 8.70	281.0 11.06	6.5 0.26	0.122	2300	1900	14.00 30.70
200.000 7.8740	360.000 14.1732	58.000 2.2835	243.000 9.5669	1090 245000	870 196000	NU240EMA	4.0 0.16	4.0 0.16	236.9 9.33	323.0 12.72	4.7 0.19	0.137	1700	1500	26.50 58.30
200.000 7.8740	360.000 14.1732	58.000 2.2835	243.000 9.5669	1090 245000	870 196000	NJ240EMA	4.0 0.16	4.0 0.16	236.9 9.33	323.0 12.72	4.7 0.19	0.137	1700	1500	27.00 59.40
200.000 7.8740	360.000 14.1732	98.000 3.8583	241.000 9.4882	1920 431000	1410 316000	NU2240EMA	4.0 0.16	4.0 0.16	231.5 9.11	325.0 12.80	7.0 0.28	0.156	1200	1100	44.40 97.70
200.000 7.8740	360.000 14.1732	98.000 3.8583	241.000 9.4882	1920 431000	1410 316000	NJ2240EMA	4.0 0.16	4.0 0.16	231.5 9.11	325.0 12.80	7.0 0.28	0.156	1200	1100	45.20 99.50
200.000 7.8740	420.000 16.5354	80.000 3.1496	258.000 10.1575	1580 354000	1360 306000	NU340EMA	5.0 0.20	5.0 0.20	249.9 9.84	370.0 14.57	7.0 0.28	0.150	1300	1200	55.80 122.70
200.000 7.8740	420.000 16.5354	80.000 3.1496	258.000 10.1575	1580 354000	1360 306000	NJ340EMA	5.0 0.20	5.0 0.20	249.9 9.84	370.0 14.57	7.0 0.28	0.150	1300	1200	56.70 124.70
200.000 7.8740	420.000 16.5354	138.000 5.4331	253.000 9.9606	2760 619000	2250 505000	NU2340EMA	5.0 0.20	5.0 0.20	240.7 9.48	377.0 14.84	9.2 0.36	0.167	1000	940	93.20 205.00
200.000 7.8740	420.000 16.5354	138.000 5.4331	253.000 9.9606	2760 619000	2250 505000	NJ2340EMA	5.0 0.20	5.0 0.20	240.7 9.48	377.0 14.84	9.2 0.36	0.167	1000	940	94.80 208.70
220.000 8.6614	340.000 13.3858	56.000 2.2047	250.000 9.8425	765 172000	565 127000	NU1044MA	3.0 0.12	3.0 0.12	242.6 9.55	310.0 12.20	8.4 0.33	0.132	2000	1700	18.40 40.40
220.000 8.6614	340.000 13.3858	56.000 2.2047	250.000 9.8425	765 172000	565 127000	NJ1044MA	3.0 0.12	3.0 0.12	242.6 9.55	310.0 12.20	8.4 0.33	0.132	2000	1700	18.90 41.60

⁽¹⁾Based on 1 x 10⁶ revolutions L₁₀ life, for the ISO life calculation method.

⁽²⁾The radial internal clearance (RIC) for the bearing assembly must be included when ordering the complete assembly.

⁽³⁾Permissible axial displacement from normal position of one bearing ring in relation to the other.

Continued on next page.

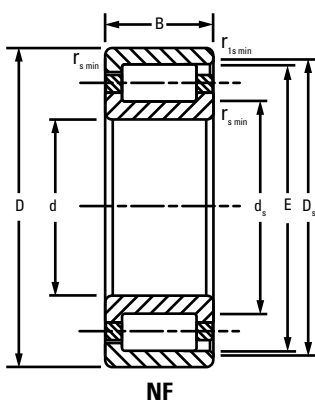
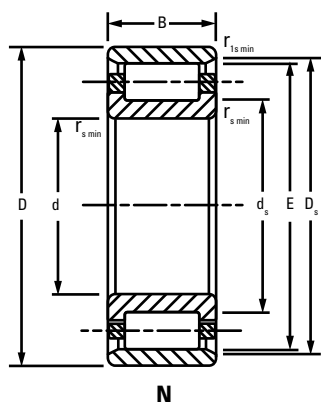

Bearing Dimensions				Load Rating		Bearing Part Number ⁽²⁾	Mounting Data				s ⁽³⁾	Geo-metry Factor C _g	Thermal Speed Ratings		Weight
Bore d	O.D. D	Width B	DUR/DOR F/E	Static C ₀	Dynamic C ₁ ⁽¹⁾		Chamfer		Backing Diameter				Oil	Grease	
mm in.	mm in.	mm in.	mm in.	kN lbf.	kN lbf.		r _{smin} mm in.	r _{1smin} mm in.	Shaft d _s mm in.	Housing D _s mm in.			RPM	RPM	
220.000 8.6614	340.000 13.3858	90.000 3.5433	250.000 9.8425	765 172000	1210 272000	NU3044MA	3.0 0.12	3.0 0.12	242.5 9.55	314.0 12.36	8.4 0.33	0.163	1100	940	30.70 67.60
220.000 8.6614	400.000 15.7480	65.000 2.5591	268.000 10.5512	1290 290000	1040 233000	NU244EMA	4.0 0.16	4.0 0.16	261.2 10.28	358.0 14.09	4.0 0.16	0.148	1500	1400	36.90 81.20
220.000 8.6614	400.000 15.7480	65.000 2.5591	268.000 10.5512	1290 290000	1040 233000	NJ244EMA	4.0 0.16	4.0 0.16	261.2 10.28	358.0 14.09	4.0 0.16	0.148	1500	1400	37.60 82.70
220.000 8.6614	400.000 15.7480	108.000 4.2520	259.000 10.1969	2370 533000	1820 409000	NU2244EMA	4.0 0.16	4.0 0.16	250.7 9.87	363.0 14.29	7.3 0.29	0.165	1000	970	60.80 133.80
220.000 8.6614	400.000 15.7480	108.000 4.2520	259.000 10.1969	2370 533000	1820 409000	NJ2244EMA	4.0 0.16	4.0 0.16	250.7 9.87	363.0 14.29	7.3 0.29	0.165	1000	970	61.80 136.00
220.000 8.6614	460.000 18.1102	88.000 3.4646	282.000 11.1024	1930 433000	1650 370000	NU344EMA	5.0 0.20	5.0 0.20	272.9 10.74	406.0 15.98	7.5 0.30	0.162	1100	1000	73.70 162.10
220.000 8.6614	460.000 18.1102	88.000 3.4646	282.000 11.1024	1930 433000	1650 370000	NJ344EMA	5.0 0.20	5.0 0.20	272.9 10.74	406.0 15.98	7.5 0.30	0.162	1100	1000	74.90 164.70
220.000 8.6614	460.000 18.1102	145.000 5.7087	277.000 10.9055	3130 704000	2550 574000	NU2344EMA	5.0 0.20	5.0 0.20	264.1 10.40	413.0 16.26	11.2 0.44	0.178	910	840	118.50 260.70
220.000 8.6614	460.000 18.1102	145.000 5.7087	277.000 10.9055	3130 704000	2550 574000	NJ2344EMA	5.0 0.20	5.0 0.20	264.1 10.40	413.0 16.26	11.2 0.44	0.178	910	840	120.60 265.20
220.000 8.6614	460.000 18.1102	145.000 5.7087	413.000 16.2598	3130 704000	2550 574000	N2344EMB	5.0 0.20	5.0 0.20	277.0 10.91	425.9 16.77	10.2 0.40	0.178	910	840	117.50 258.60
240.000 9.4488	360.000 14.1732	56.000 2.2047	270.000 10.6299	838 188000	595 134000	NU1048MA	3.0 0.12	3.0 0.12	262.6 10.34	330.0 12.99	7.0 0.28	0.140	1900	1500	19.70 43.40
240.000 9.4488	440.000 17.3228	72.000 2.8346	293.000 11.5354	1570 352000	1250 281000	NU248EMA	4.0 0.16	4.0 0.16	285.5 11.24	393.0 15.47	6.0 0.24	0.159	1300	1100	50.30 110.60
240.000 9.4488	440.000 17.3228	72.000 2.8346	293.000 11.5354	1570 352000	1250 281000	NJ248EMA	4.0 0.16	4.0 0.16	285.5 11.24	393.0 15.47	6.0 0.24	0.159	1300	1100	51.10 112.50
240.000 9.4488	500.000 19.6850	95.000 3.7402	306.000 12.0472	2530 568000	2080 468000	NU348EMA	5.0 0.20	5.0 0.20	295.0 11.61	442.0 17.40	7.5 0.30	0.170	1100	990	96.10 211.40
240.000 9.4488	500.000 19.6850	95.000 3.7402	306.000 12.0472	2530 568000	2080 468000	NJ348EMA	5.0 0.20	5.0 0.20	295.0 11.61	442.0 17.40	7.5 0.30	0.170	1100	990	97.50 214.50

⁽¹⁾Based on 1 x 10⁶ revolutions L₁₀ life, for the ISO life calculation method.

⁽²⁾The radial internal clearance (RIC) for the bearing assembly must be included when ordering the complete assembly.

⁽³⁾Permissible axial displacement from normal position of one bearing ring in relation to the other.

Continued on next page.

CYLINDRICAL ROLLER BEARINGS

ONE-ROW METRIC ISO SERIES

ONE-ROW METRIC ISO SERIES – continued

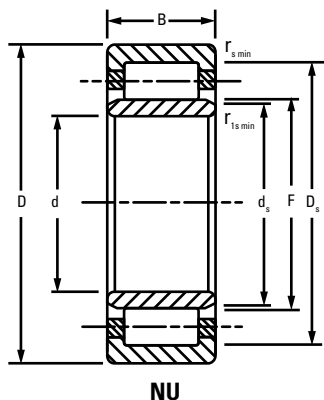

NU

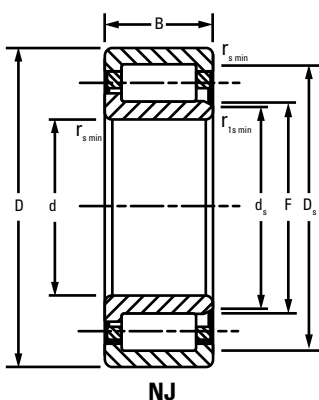

NJ

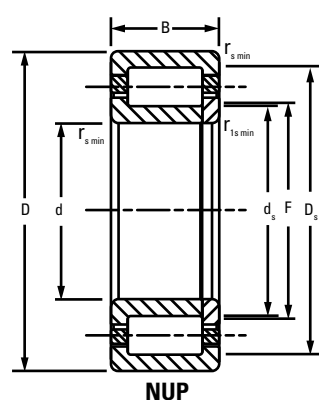

NUP

Bearing Dimensions				Load Rating		Bearing Part Number ⁽²⁾	Mounting Data				s ⁽³⁾	Geo-metry Factor C _g	Thermal Speed Ratings		Weight
Bore d	O.D. D	Width B	DUR/DOR F/E	Static C ₀	Dynamic C ₁ ⁽¹⁾		Chamfer		Backing Diameter				Oil	Grease	
mm in.	mm in.	mm in.	mm in.	kN lbf.	kN lbf.		r _{s min} mm in.	r _{1s min} mm in.	Shaft d _s mm in.	Housing D _s mm in.			mm in.	RPM	
240.000 9.4488	500.000 19.6850	155.000 6.1024	303.000 11.9291	3760 846000	2970 668000	NU2348EMA	5.0 0.20	5.0 0.20	287.8 11.33	447.0 17.60	11.9 0.47	0.192	770	700	153.00 336.60
240.000 9.4488	500.000 19.6850	155.000 6.1024	303.000 11.9291	3760 846000	2970 668000	NJ2348EMA	5.0 0.20	5.0 0.20	287.8 11.33	447.0 17.60	11.9 0.47	0.192	770	700	155.70 342.50
260.000 10.2362	400.000 15.7480	65.000 2.5591	296.000 11.6535	1040 233000	737 166000	NU1052MA	4.0 0.16	4.0 0.16	287.2 11.31	364.0 14.33	8.8 0.35	0.151	1700	1400	29.20 64.10
260.000 10.2362	400.000 15.7480	104.000 4.0945	294.000 11.5748	2500 563000	1580 354000	NU3052MA	4.0 0.16	4.0 0.16	284.9 11.22	370.0 14.57	7.5 0.30	0.170	860	770	29.20 64.10
260.000 10.2362	480.000 18.8976	80.000 3.1496	320.000 12.5984	1720 387000	1320 297000	NU252MA	5.0 0.20	5.0 0.20	308.8 12.16	420.0 16.54	7.0 0.28	0.168	1200	1000	69.70 153.30
260.000 10.2362	480.000 18.8976	80.000 3.1496	320.000 12.5984	1720 387000	1320 297000	NUP252MA	5.0 0.20	5.0 0.20	307.0 12.09	420.0 16.54	– –	0.168	1200	1000	72.30 159.06
260.000 10.2362	480.000 18.8976	130.000 5.1181	320.000 12.5984	2950 663000	2030 457000	NU2252MA	5.0 0.20	5.0 0.20	305.6 12.03	420.0 16.54	11.6 0.46	0.192	850	780	113.00 248.60
260.000 10.2362	540.000 21.2598	165.000 6.4961	324.000 12.7559	4200 945000	3370 758000	NU2352EMA	6.0 0.24	6.0 0.24	308.8 12.16	484.0 19.06	12.2 0.48	0.201	700	640	186.10 409.30
280.000 11.0236	420.000 16.5354	65.000 2.5591	316.000 12.4409	1090 245000	754 169000	NU1056MA	4.0 0.16	4.0 0.16	306.4 12.06	384.0 15.12	8.0 0.31	0.157	1600	1300	31.00 68.20
300.000 11.8110	460.000 18.1102	74.000 2.9134	340.000 13.3858	1430 322000	1000 225000	NU1060MA	4.0 0.16	4.0 0.16	329.8 12.98	420.0 16.54	10.7 0.42	0.169	1400	1200	43.70 96.10
320.000 12.5984	440.000 17.3228	56.000 2.2047	350.000 13.7795	1210 272000	767 172000	NU1964MA	3.0 0.12	3.0 0.12	342.0 13.46	414.0 16.30	5.6 0.22	0.170	770	660	26.90 59.18
320.000 12.5984	440.000 17.3228	72.000 2.8346	413.000 16.2598	2010 453000	1150 259000	NF2964EMB	3.0 0.12	3.0 0.12	349.0 13.74	419.7 16.52	4.0 0.16	0.191	710	620	33.70 74.20
320.000 12.5984	480.000 18.8976	74.000 2.9134	360.000 14.1732	1500 337000	1020 230000	NU1064MA	4.0 0.16	4.0 0.16	349.8 13.77	440.0 17.32	9.2 0.36	0.176	1300	1100	45.90 101.00
320.000 12.5984	580.000 22.8346	150.000 5.9055	390.000 15.3543	3920 882000	2690 605000	NU2264MA	5.0 0.20	5.0 0.20	374.2 14.73	510.0 20.08	15.9 0.63	0.199	680	620	178.50 392.70
340.000 13.3858	460.000 18.1102	72.000 2.8346	431.000 16.9685	2090 469000	1170 263000	NF2968EMB	3.0 0.12	3.0 0.12	367.0 14.45	437.8 17.24	4.0 0.16	0.197	660	580	35.50 78.00

⁽¹⁾Based on 1 x 10⁶ revolutions L₁₀ life, for the ISO life calculation method.

⁽²⁾The radial internal clearance (RIC) for the bearing assembly must be included when ordering the complete assembly.

⁽³⁾Permissible axial displacement from normal position of one bearing ring in relation to the other.

Continued on next page.

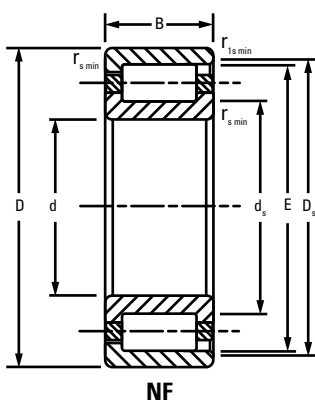
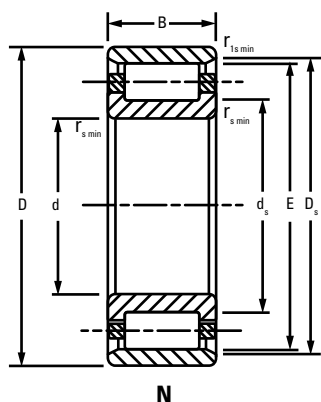

Bearing Dimensions				Load Rating		Bearing Part Number ⁽²⁾	Mounting Data				s ⁽³⁾	Geo-metry Factor C _g	Thermal Speed Ratings		Weight
Bore d	O.D. D	Width B	DUR/DOR F/E	Static C ₀	Dynamic C ₁ ⁽¹⁾		Chamfer		Backing Diameter				Oil	Grease	
mm in.	mm in.	mm in.	mm in.	kN lbf.	kN lbf.		r _{smin} mm in.	r _{1smin} mm in.	Shaft d _s mm in.	Housing D _s mm in.					
340.000 13.3858	520.000 20.4724	82.000 3.2283	385.000 15.1575	1800 405000	1240 278000	NU1068MA	5.0 0.20	5.0 0.20	371.5 14.63	475.0 18.70	7.9 0.31	0.186	1200	1000	61.30 134.90
340.000 13.3858	520.000 20.4724	133.000 5.2362	385.000 15.1575	4280 961000	2550 572000	NU3068EMA	5.0 0.20	5.0 0.20	374.3 14.74	481.0 18.94	10.0 0.39	0.228	580	530	105.50 232.00
340.000 13.3858	580.000 22.8346	190.000 7.4803	399.000 15.7087	7010 158000	4300 967000	NU3168EMA	5.0 0.20	5.0 0.20	388.8 15.31	523.0 20.59	8.5 0.34	0.253	480	450	224.70 494.40
360.000 14.1732	750.000 29.5276	224.000 8.8189	465.000 18.3071	8060 1810000	5740 1290000	NU2372EMA	7.5 0.30	7.5 0.30	443.3 17.45	655.0 25.79	12.7 0.50	0.266	430	400	498.10 1095.90
360.000 14.1732	540.000 21.2598	82.000 3.2283	405.000 15.9449	1890 424000	1270 285000	NU1072MA	5.0 0.20	5.0 0.20	390.3 15.37	495.0 19.49	6.9 0.27	0.193	1100	940	64.20 141.20
380.000 14.9606	560.000 22.0472	82.000 3.2283	425.000 16.7323	1970 443000	1300 291000	NU1076MA	5.0 0.20	5.0 0.20	412.4 16.24	515.0 20.28	9.0 0.35	0.199	1100	890	67.20 147.90
400.000 15.7480	540.000 21.2598	82.000 3.2283	435.000 17.1260	2920 657000	1600 360000	NJ2980EMA	4.0 0.16	4.0 0.16	426.6 16.80	511.0 20.12	4.0 0.16	0.226	520	460	54.80 120.50
400.000 15.7480	600.000 23.6220	90.000 3.5433	450.000 17.7165	2290 516000	1530 343000	NU1080MA	5.0 0.20	5.0 0.20	436.4 17.18	550.0 21.65	10.0 0.39	0.209	980	830	87.50 192.60
400.000 15.7480	600.000 23.6220	118.000 4.6457	449.000 17.6772	4290 965000	2620 589000	NU2080EMA	5.0 0.20	5.0 0.20	440.4 17.34	557.0 21.93	9.6 0.38	0.240	490	440	119.30 262.40
420.000 16.5354	560.000 22.0472	82.000 3.2283	531.000 20.9055	3020 680000	1630 366000	NF2984EMB	4.0 0.16	4.0 0.16	455.0 17.91	537.9 21.18	5.0 0.20	0.232	490	440	57.20 125.80
440.000 17.3228	650.000 25.5906	94.000 3.7008	493.000 19.4094	2760 620000	1760 395000	NU1088MA	6.0 0.24	6.0 0.24	480.0 18.90	597.0 23.50	11.0 0.43	0.226	860	730	106.60 234.60
440.000 17.3228	650.000 25.5906	122.000 4.8031	487.000 19.1732	4900 1100000	2950 663000	NU2088EMA	6.0 0.24	6.0 0.24	476.1 18.74	603.0 23.74	8.5 0.33	0.255	430	390	141.00 310.10
440.000 17.3228	720.000 28.3465	226.000 8.8976	509.000 20.0394	9330 2100000	5740 1290000	NU3188EMA	6.0 0.24	6.0 0.24	490.0 19.29	665.0 26.18	13.6 0.54	0.292	370	350	371.20 816.50
460.000 18.1102	580.000 22.8346	72.000 2.8346	489.000 19.2520	2660 599000	1310 294000	NJ2892EMA	3.0 0.12	3.0 0.12	482.0 18.98	553.0 21.77	4.0 0.16	0.238	470	410	45.70 100.50
460.000 18.1102	620.000 24.4094	95.000 3.7402	579.000 22.7953	3690 830000	1970 443000	NF2992EMB	4.0 0.16	4.0 0.16	495.0 19.49	586.6 23.09	6.5 0.26	0.249	440	390	84.50 185.90

⁽¹⁾Based on 1 x 10⁶ revolutions L₁₀ life, for the ISO life calculation method.

⁽²⁾The radial internal clearance (RIC) for the bearing assembly must be included when ordering the complete assembly.

⁽³⁾Permissible axial displacement from normal position of one bearing ring in relation to the other.

Continued on next page.

CYLINDRICAL ROLLER BEARINGS

ONE-ROW METRIC ISO SERIES

ONE-ROW METRIC ISO SERIES – continued

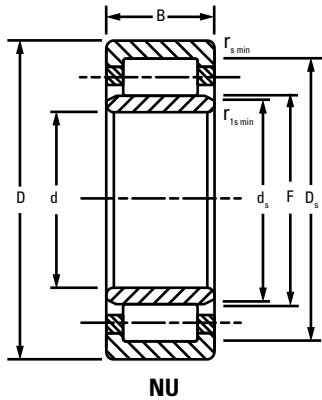

NU

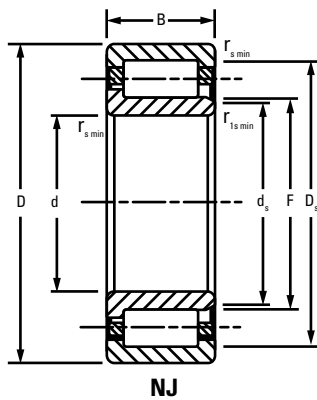

NJ

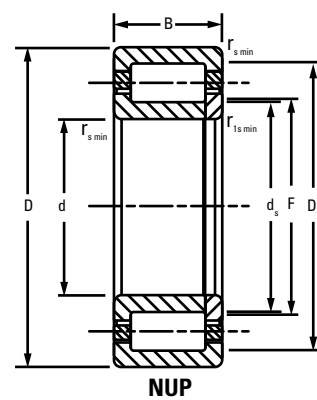

NUP

Bearing Dimensions				Load Rating		Bearing Part Number ⁽²⁾	Mounting Data				s ⁽³⁾	Geo-metry Factor C _g	Thermal Speed Ratings		Weight
Bore d	O.D. D	Width B	DUR/DOR F/E	Static C ₀	Dynamic C ₁ ⁽¹⁾		Chamfer		Backing Diameter				Oil	Grease	
mm in.	mm in.	mm in.	mm in.	kN lbf.	kN lbf.		r _{s min} mm in.	r _{1s min} mm in.	Shaft d _s mm in.	Housing D _s mm in.			RPM	RPM	
460.000 18.1102	760.000 29.9213	240.000 9.4488	529.300 20.8386	10100 2270000	6100 1370000	NU3192EMA	7.5 0.30	7.5 0.30	505.6 19.91	689.3 27.14	17.2 0.68	0.302	360	330	448.80 987.30
480.000 18.8976	700.000 27.5591	100.000 3.9370	536.000 21.1024	3950 887000	2360 531000	NU1096EMA	6.0 0.24	6.0 0.24	527.7 20.78	646.0 25.43	10.4 0.41	0.253	710	620	131.80 290.00
480.000 18.8976	700.000 27.5591	100.000 3.9370	536.000 21.1024	3920 881000	2360 531000	NJ1096EMA	6.0 0.24	6.0 0.24	528.5 20.81	646.0 25.43	10.4 0.41	0.253	710	620	138.00 304.20
500.000 19.6850	830.000 32.6772	264.000 10.3937	576.000 22.6772	12000 2690000	7490 1680000	NU31/500EMA	7.5 0.30	7.5 0.30	555.7 21.88	764.0 30.08	18.0 0.71	0.319	310	290	585.00 1287.10
560.000 22.0472	680.000 26.7717	56.000 2.2047	594.000 23.3858	1730 388000	806 181000	NU18/560MA	3.0 0.12	3.0 0.12	584.3 23.00	650.0 25.59	6.6 0.26	0.240	410	350	40.90 90.00
600.000 23.6220	870.000 34.2520	200.000 7.8740	661.000 26.0236	11000 2480000	6180 1390000	NU30/600EMA	6.0 0.24	6.0 0.24	646.5 25.45	821.0 32.32	14.8 0.58	0.338	270	250	396.80 872.90
630.000 24.8031	920.000 36.2205	170.000 6.6929	699.000 27.5197	9570 2150000	5390 1210000	NU20/630EMA	7.5 0.30	7.5 0.30	684.6 26.95	855.0 33.66	10.9 0.43	0.336	260	240	386.10 849.40
670.000 26.3780	980.000 38.5827	180.000 7.0866	746.000 29.3701	11100 2490000	6170 1390000	NU20/670EMA	7.5 0.30	7.5 0.30	730.0 28.74	912.0 35.91	11.7 0.46	0.356	230	210	468.80 1031.30
670.000 26.3780	980.000 38.5827	230.000 9.0551	744.000 29.2913	14000 3140000	7510 1690000	NU30/670EMA	7.5 0.30	7.5 0.30	725.1 28.55	914.0 35.98	17.6 0.69	0.375	230	210	608.10 1337.80
710.000 27.9528	870.000 34.2520	95.000 3.7402	751.000 29.5669	5110 1150000	2200 494000	NJ28/710EMA	4.0 0.16	4.0 0.16	740.9 29.17	831.0 32.72	7.8 0.31	0.328	270	240	125.40 275.80
710.000 27.9528	950.000 37.4016	140.000 5.5118	770.000 30.3150	8190 1840000	4020 903000	NJ29/710MA	6.0 0.24	6.0 0.24	756.6 29.79	890.0 35.04	10.5 0.41	0.351	250	220	307.00 676.80
750.000 29.5276	1090.000 42.9134	195.000 7.6772	832.000 32.7559	13800 3110000	7550 1700000	NU20/750EMA	7.5 0.30	7.5 0.30	817.6 32.19	1018.0 40.08	13.2 0.52	0.388	190	180	621.20 1366.50
800.000 31.4961	1150.000 45.2756	200.000 7.8740	882.000 34.7244	14600 3290000	8040 1810000	NU20/800EMA	7.5 0.30	7.5 0.30	864.6 34.04	1080.0 42.52	13.4 0.53	0.400	180	170	690.30 1518.60
850.000 33.4646	1220.000 48.0315	212.000 8.3465	937.000 36.8898	16200 3640000	8850 1990000	NU20/850EMA	7.5 0.30	7.5 0.30	917.5 36.12	1147.0 45.16	14.6 0.57	0.418	170	160	820.30 1804.60

⁽¹⁾Based on 1 x 10⁶ revolutions L₁₀ life, for the ISO life calculation method.

⁽²⁾The radial internal clearance (RIC) for the bearing assembly must be included when ordering the complete assembly.

⁽³⁾Permissible axial displacement from normal position of one bearing ring in relation to the other.

Continued on next page.

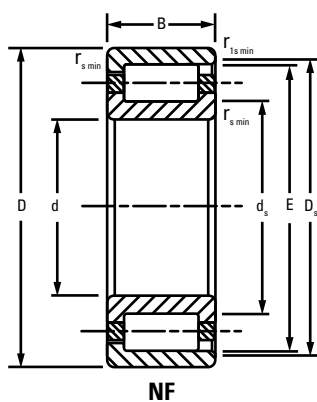
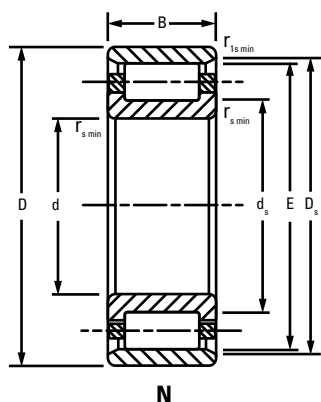

Bearing Dimensions				Load Rating		Bearing Part Number ⁽²⁾	Mounting Data				s ⁽³⁾	Geo-metry Factor C _g	Thermal Speed Ratings		Weight
Bore	O.D.	Width	DUR/DOR	Static	Dynamic		Chamfer		Backing Diameter				Oil	Grease	
d	D	B	F/E	C ₀	C ₁ ⁽¹⁾		r _{smin}	r _{1smin}	Shaft d _s	Housing D _s					
mm	mm	mm	mm	kN	kN	mm	mm	mm	mm	mm	RPM	RPM	kg		
in.	in.	in.	in.	lbf.	lbf.	in.	in.	in.	in.	in.			lbs.		
900.000 35.4331	1180.000 46.4567	206.000 8.1102	969.000 38.1496	16800 3770000	7500 1690000	NU39/900EMA	6.0 0.24	6.0 0.24	949.9 37.40	1119.0 44.06	10.0 0.39	0.447	160	150	609.30 1340.40
900.000 35.4331	1280.000 50.3937	218.000 8.5827	990.000 38.9764	16900 3800000	9030 2030000	NU20/900EMA	7.5 0.30	7.5 0.30	968.5 38.13	1200.0 47.24	15.5 0.61	0.432	160	150	915.80 2014.80
1120.000 44.0945	1360.000 53.5433	106.000 4.1732	1162.000 45.7480	8370 1880000	3680 828000	NJ18/1120EMA	6.0 0.24	6.0 0.24	1167.5 45.96	1310.0 51.57	10.0 0.39	0.422	150	130	323.80 712.40

⁽¹⁾Based on 1 x 10⁶ revolutions L₁₀ life, for the ISO life calculation method.

⁽²⁾The radial internal clearance (RIC) for the bearing assembly must be included when ordering the complete assembly.

⁽³⁾Permissible axial displacement from normal position of one bearing ring in relation to the other.

ONE-ROW STANDARD SERIES

- Similar in construction to ISO counterparts.
- Designed to ABMA standards.
- Inch bearing sizes identified by "I" in the part number.

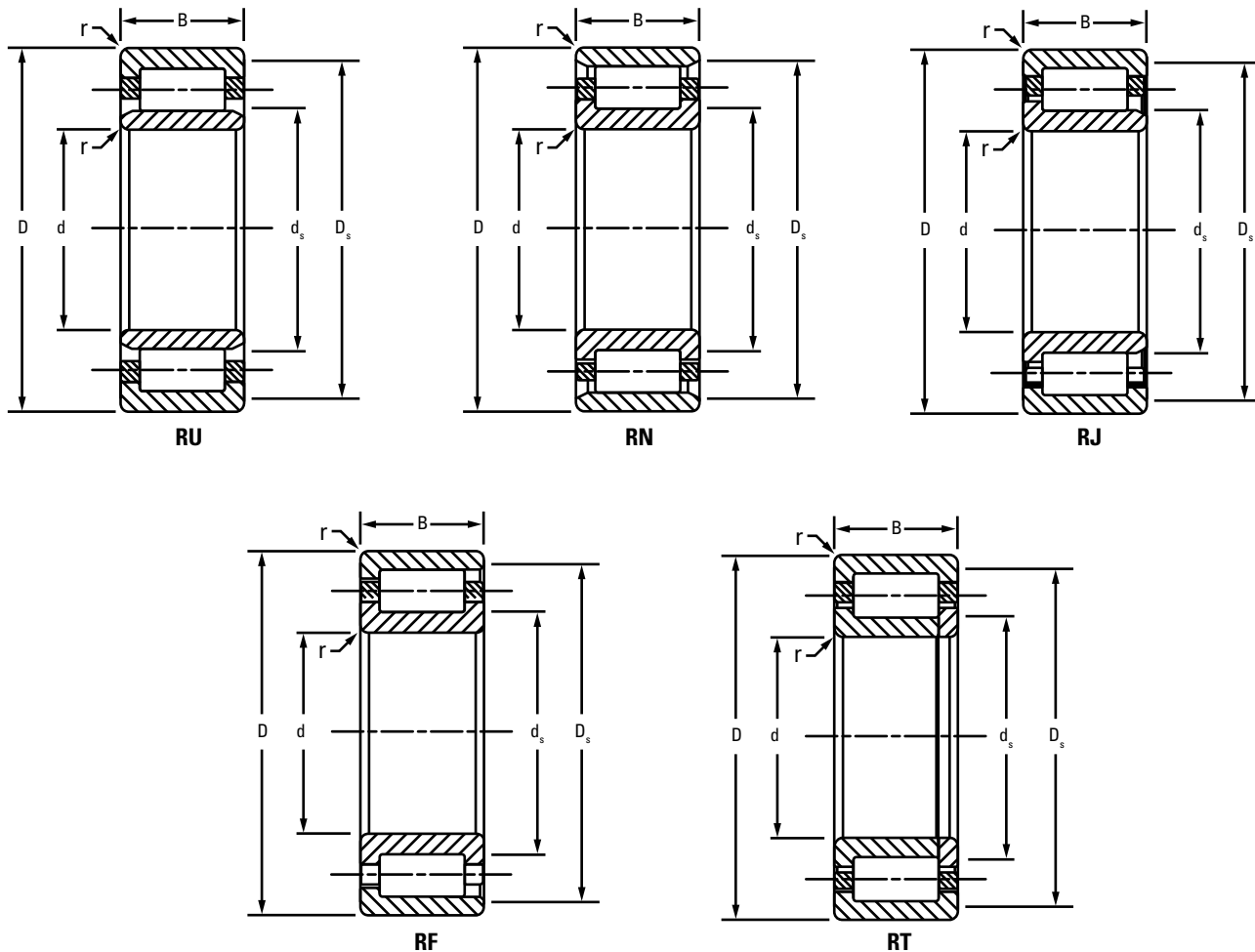

Bearing Number and Style ⁽¹⁾					Bearing Dimensions			Fillet Radius (Max.) r ⁽²⁾	Backing Diameter		Load Rating		Geometry Factor C _g	Thermal Speed Ratings		Weight
RU RIU	RN RIN	RJ RIJ	RF RIF	RT RIT	Bore d	O.D. D	Width B		Shaft d _s	Housing D _s	Static C ₀	Dynamic C ₁ ⁽³⁾		Oil	Grease	
					mm in.	mm in.	mm in.	mm in.	mm in.	mm in.	kN lbf.	kN lbf.	RPM	RPM	kg lbs.	
105RU32	105RN32	105RJ32	105RF32	105RT32	105.000 4.1339	190.000 7.4803	65.100 2.5625	2.0 0.08	120.7 4.75	174.6 6.88	640 144000	471 106000	0.115	2800	2500	8.3 18.3
170RU51	170RN51	170RJ51	170RF51	170RT51	170.000 6.6929	265.000 10.4331	42.000 1.6535	2.50 0.10	184.3 7.26	246.1 9.69	521 117000	391 87800	0.108	1600	1300	8.6 18.8
170RU91	170RN91	170RJ91	170RF91	170RT91	170.000 6.6929	265.000 10.4331	76.200 3.0000	2.5 0.10	187.3 7.38	247.7 9.75	1170 264000	735 165000	0.131	1500	1400	16.1 35.5
170RU93	170RN93	170RJ93	170RF93	170RT93	170.000 6.6929	360.000 14.1732	139.700 5.5000	3.0 0.12	204.7 8.06	325.4 12.81	2580 580000	1820 410000	0.156	1200	1100	73.6 162.4
180RU51	180RN51	180RJ51	180RF51	180RT51	180.000 7.0866	280.000 11.0236	44.000 1.7323	2.5 0.10	196.1 7.72	262.7 10.34	560 126000	419 94200	0.114	1500	1300	10.3 22.7
180RU91	180RN91	180RJ91	180RF91	180RT91	180.000 7.0866	280.000 11.0236	82.550 3.2500	2.5 0.10	196.9 7.75	261.9 10.31	1440 323000	833 187000	0.142	1400	1200	19.4 42.9
190RU91	190RN91	190RJ91	190RF91	190RT91	190.000 7.4803	300.000 11.8110	85.725 3.3750	2.5 0.10	209.6 8.25	281.0 11.06	1600 360000	973 219000	0.147	1300	1100	23.8 52.5
190RU92	190RN92	190RJ92	190RF92	190RT92	190.000 7.4803	340.000 13.3858	114.300 4.5000	3.0 0.12	217.5 8.56	311.9 12.28	2210 497000	1450 326000	0.156	1200	1000	47.3 104.2
200RU91	200RN91	200RJ91	200RF91	200RT91	200.000 7.8740	320.000 12.5984	88.900 3.5000	3.0 0.12	218.9 8.62	294.9 11.61	1740 391000	1060 239000	0.151	1200	1000	27.7 60.9
200RU92	200RN92	200RJ92	200RF92	200RT92	200.000 7.8740	360.000 14.1732	120.650 4.7500	3.0 0.12	230.1 9.06	330.2 13.00	2590 581000	1630 366000	0.166	1000	940	56.8 125.2
210RU92	210RN92	210RJ92	210RF92	210RT92	210.000 8.2677	380.000 14.9606	127.000 5.0000	3.0 0.12	239.8 9.44	350.0 13.78	2640 593000	1740 391000	0.167	1000	920	66.1 145.8
220RU51	220RN51	220RJ51	220RF51	220RT51	220.000 8.6614	350.000 13.7796	51.000 2.0079	2.5 0.10	243.7 9.59	326.2 12.84	830 187000	612 138000	0.133	1100	960	19.6 43.2
220RU91	220RN91	220RJ91	220RF91	220RT91	220.000 8.6614	350.000 13.7795	98.425 3.8750	2.5 0.10	239.3 9.42	324.6 12.78	2090 470000	1290 289000	0.162	1000	930	37.6 82.9
220RU92	220RN92	220RJ92	220RF92	220RT92	220.000 8.6614	400.000 15.7480	133.350 5.2500	3.0 0.12	252.4 9.94	368.3 14.50	3230 727000	2010 452000	0.180	880	810	78.4 172.9
240RU91	240RN91	240RJ91	240RF91	240RT91	240.000 9.4488	390.000 15.3543	107.950 4.2500	3.0 0.12	265.2 10.44	365.3 14.38	2670 600000	1580 355000	0.178	880	790	53.4 117.7
250RU91	250RN91	250RJ91	250RF91	250RT91	250.000 9.8425	410.000 16.1417	111.125 4.3750	3.0 0.12	277.8 10.94	382.6 15.06	2720 611000	1680 377000	0.180	850	770	60.9 134.3

⁽¹⁾The radial internal clearance (RIC) for the bearing assembly must be included when ordering the complete assembly.

⁽²⁾Maximum shaft or housing fillet radius that bearing corners will clear.

⁽³⁾Based on 1 x 10⁶ revolutions L₁₀ life, for the ISO life calculation method.

CYLINDRICAL ROLLER BEARINGS

FULL-COMPLEMENT (NCF)

FULL-COMPLEMENT (NCF)

- Single-row, full-complement cylindrical roller bearings.
- Features include integral flanges on the inner and outer rings.
- Can manage axial loads in one direction and small axial displacement.

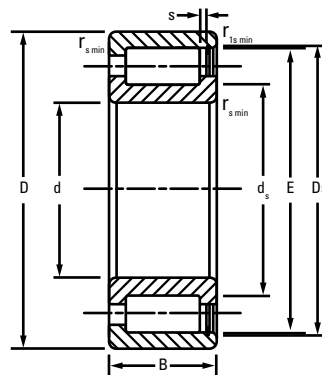

NCF

Bearing Dimensions				Load Rating		Bearing Part Number ⁽²⁾	Mounting Data				s ⁽³⁾	Geo-metry Factor C _g	Thermal Speed Ratings		Weight
Bore d	O.D. D	Width B	DUR/DOR F/E	Static C ₀	Dynamic C ₁ ⁽¹⁾		Chamfer		Backing Diameter				Oil	Grease	
							r _{s min}	r _{1s min}	Shaft d _s	Housing D _s					
mm in.	mm in.	mm in.	mm in.	kN lbf.	kN lbf.	mm in.	mm in.	mm in.	mm in.	mm in.	RPM	RPM	kg lbs.		
110.000 4.3307	150.000 5.9055	24.000 0.9449	141.100 5.5551	223 50100	146 32900	NCF2922V	1.1 0.04	1.0 0.04	119.1 4.69	142.1 5.59	1.5 0.06	0.136	1200	1000	1.20 2.65
120.000 4.7244	165.000 6.4961	27.000 1.0630	154.000 6.0630	297 66800	188 42400	NCF2924V	1.1 0.04	1.0 0.04	130.0 5.12	155.0 6.10	1.55 0.061	0.150	1200	970	1.70 3.80
130.000 5.1181	180.000 7.0866	30.000 1.1811	166.800 6.5669	361 81100	225 50600	NCF2926V	1.5 0.06	1.1 0.04	140.8 5.54	167.5 6.59	2.00 0.079	0.160	1100	920	2.30 5.00
140.000 5.5118	190.000 7.4803	30.000 1.1811	179.600 7.0709	389 87300	243 54700	NCF2928V	1.5 0.06	1.1 0.04	151.6 5.97	180.2 7.10	1.9 0.075	0.167	1000	850	2.40 5.30
150.000 5.9055	210.000 8.2677	36.000 1.4173	196.400 7.7323	506 114000	328 73800	NCF2930V	2.0 0.08	1.1 0.04	162.4 6.39	200.5 7.89	2.20 0.087	0.128	1010	840	3.80 8.30
160.000 6.2992	220.000 8.6614	36.000 1.4173	207.200 8.1575	540 121000	340 76300	NCF2932V	2.0 0.08	1.1 0.04	173.2 6.82	208.5 8.21	2.20 0.087	0.133	940	790	4.00 8.70
170.000 6.6929	230.000 9.0551	36.000 1.4173	218.000 8.5827	574 129000	350 78700	NCF2934V	2.0 0.08	1.1 0.04	184.0 7.24	219.5 8.64	2.20 0.087	0.116	890	740	4.20 9.30
180.000 7.0866	250.000 9.8425	42.000 1.6535	231.500 9.1142	711 160000	436 98000	NCF2936V	2.0 0.08	1.1 0.04	193.5 7.62	232.5 9.15	2.50 0.098	0.123	850	710	6.30 13.80
190.000 7.4803	260.000 10.2362	42.000 1.6535	244.000 9.6063	803 180000	487 109000	NCF2938V	2.0 0.08	1.1 0.04	204.0 8.03	248.2 9.77	1.50 0.059	0.129	780	660	6.50 14.30
200.000 7.8740	250.000 9.8425	24.000 0.9449	237.500 9.3504	337 75700	188 42400	NCF1840V	1.5 0.06	1.1 0.04	211.5 8.33	238.5 9.39	1.80 0.071	0.146	740	610	2.52 5.60
200.000 7.8740	280.000 11.0236	48.000 1.8898	261.100 10.2795	971 218000	587 132000	NCF2940V	2.1 0.08	1.5 0.06	217.1 8.55	262.0 10.32	1.95 0.077	0.137	730	620	9.20 20.10
220.000 8.6614	270.000 10.6299	24.000 0.9449	257.700 10.1457	370 83100	198 44400	NCF1844V	1.5 0.06	1.1 0.04	231.7 9.12	258.7 10.19	1.80 0.071	0.155	670	550	2.92 6.44
220.000 8.6614	300.000 11.8110	48.000 1.8898	282.100 11.1063	1070 239000	615 138000	NCF2944V	2.1 0.08	1.5 0.06	238.1 9.37	284.0 11.18	1.95 0.077	0.146	650	550	9.90 21.70
260.000 10.2362	320.000 12.5984	28.000 1.1024	307.000 12.0866	553 124000	292 65500	NCF1852V	2.0 0.08	1.1 0.04	275 10.83	308.0 12.13	1.80 0.071	0.140	580	480	4.80 10.60
260.000 10.2362	360.000 14.1732	60.000 2.3622	333.400 13.1260	1480 333000	837 188000	NCF2952V	2.1 0.08	2.1 0.08	281.3 11.07	334.6 13.17	4.00 0.157	0.167	540	460	18.50 40.80

⁽¹⁾Based on 1 x 10⁶ revolutions L₁₀ life, for the ISO life calculation method.

⁽²⁾The radial internal clearance (RIC) for the bearing assembly must be included when ordering the complete assembly.

⁽³⁾Permissible axial displacement from normal position of one bearing ring in relation to the other.

Continued on next page.

Bearing Dimensions				Load Rating		Bearing Part Number ⁽²⁾	Mounting Data				s ⁽³⁾	Geo-metry Factor C _g	Thermal Speed Ratings		Weight
							Chamfer		Backing Diameter				Oil	Grease	
Bore d	O.D. D	Width B	DUR/DOR F/E	Static C ₀	Dynamic C ₁ ⁽¹⁾		r _{smin}	r _{1smin}	Shaft d _s	Housing D _s					
mm in.	mm in.	mm in.	mm in.	kN lbf.	kN lbf.	mm in.	mm in.	mm in.	mm in.	mm in.					
300.000 11.8110	420.000 16.5354	72.000 2.8346	390.000 15.3543	2260 508000	1260 284000	NCF2960V	3.0 0.12	3.0 0.12	326.0 12.83	390.5 15.37	4.00 0.157		430 370	31.30 68.80	
320.000 12.5984	400.000 15.7480	38.000 1.4961	382.800 15.0709	900 202000	471 106000	NCF1864V	2.1 0.08	1.5 0.06	340.8 13.42	383.8 15.11	3.00 0.118		460 380	10.60 23.40	
320.000 12.5984	440.000 17.3228	72.000 2.8346	410.500 16.1614	2400 540000	1300 293000	NCF2964V	3.0 0.12	3.0 0.12	346.5 13.64	412.0 16.22	4.00 0.157		400 340	32.90 72.53	
340.000 13.3858	420.000 16.5354	38.000 1.4961	402.800 15.8583	953 214000	484 109000	NCF1868V	2.1 0.08	1.5 0.06	360.8 14.20	403.8 15.90	3.00 0.118		430 360	11.00 24.20	
380.000 14.9606	480.000 18.8976	46.000 1.8110	457.300 18.0039	1350 304000	698 157000	NCF1876V	2.1 0.08	1.5 0.06	405.3 15.96	458.3 18.04	3.50 0.138		370 310	18.90 41.60	
380.000 14.9606	520.000 20.4724	82.000 3.2283	487.300 19.1850	3360 756000	1790 402000	NCF2976V	4.0 0.16	4.0 0.16	411.3 16.19	488.8 19.24	4.00 0.157		310 270	52.90 116.62	
400.000 15.7480	500.000 19.6850	46.000 1.8110	474.000 18.6614	1410 316000	713 160000	NCF1880V	2.1 0.08	1.5 0.06	422.0 16.61	475.0 18.70	3.50 0.138		350 290	20.60 45.41	
420.000 16.5354	520.000 20.4724	46.000 1.8110	498.800 19.6378	1490 335000	733 165000	NCF1884V	2.1 0.08	1.5 0.06	446.8 17.59	499.8 19.68	3.50 0.138		330 280	21.14 46.50	
440.000 17.3228	540.000 21.2598	46.000 1.8110	515.500 20.2953	1550 347000	746 168000	NCF1888V	2.1 0.08	1.5 0.06	463.5 18.25	516.5 20.33	3.50 0.138		310 260	22.30 49.16	
460.000 18.1102	580.000 22.8346	56.000 2.2047	552.600 21.7559	2040 458000	1030 232000	NCF1892V	3.0 0.12	3.0 0.12	488.6 19.24	553.6 21.80	4.50 0.177		290 250	33.20 73.00	
460.000 18.1102	620.000 24.4094	95.000 3.7402	578.500 22.7756	4610 1040000	2310 518000	NCF2992V	4.0 0.16	4.0 0.16	494.5 19.47	580.0 22.84	5.00 0.197		240 220	84.00 185.19	
480.000 18.8976	650.000 25.5906	100.000 3.9370	615.200 24.2205	4910 1100000	2570 579000	NCF2996V	5.0 0.20	5.0 0.20	519.2 20.44	616.8 24.28	6.00 0.236		230 210	94.30 207.50	
500.000 19.6850	620.000 24.4094	56.000 2.2047	593.300 23.3583	2210 496000	1070 241000	NCF18/500V	3.0 0.12	3.0 0.12	529.3 20.84	594.3 23.40	5.0 0.197		260 220	35.90 79.00	
500.000 19.6850	670.000 26.3780	100.000 3.9370	630.900 24.8386	5060 1140000	2610 587000	NCF29/500V	5.0 0.20	5.0 0.20	534.9 21.06	632.5 24.90	6.0 0.236		220 200	97.30 214.10	
530.000 20.8661	650.000 25.5906	56.000 2.2047	624.000 24.5669	2340 525000	1100 248000	NCF18/530V	3.0 0.12	3.0 0.12	560.0 22.05	625.5 24.63	4.1 0.161		240 210	37.80 83.20	
560.000 22.0472	680.000 26.7717	56.000 2.2047	654.700 25.7756	2460 554000	1130 255000	NCF18/560V	3.0 0.12	3.0 0.12	590.7 23.26	656.2 25.84	4.1 0.161		230 190	39.20 86.30	
600.000 23.6220	730.000 28.7402	60.000 2.3622	695.200 27.3701	2630 592000	1170 263000	NCF18/600V	3.0 0.12	3.0 0.12	631.2 24.85	696.7 27.43	6.1 0.240		210 180	50.20 110.40	
630.000 24.8031	780.000 30.7087	69.000 2.7165	737.500 29.0354	3100 698000	1410 316000	NCF18/630V	4.0 0.16	4.0 0.16	665.5 26.20	739.0 29.10	7.5 0.295		200 170	72.20 159.17	
670.000 26.3780	820.000 32.2835	69.000 2.7165	782.300 30.7992	3320 746000	1450 327000	NCF18/670V	4.0 0.16	4.0 0.16	710.3 27.96	783.8 30.86	7.5 0.295		190 160	74.60 164.10	
710.000 27.9528	870.000 34.2520	74.000 2.9134	830.700 32.7047	3920 882000	1740 390000	NCF18/710V	4.0 0.16	4.0 0.16	750.7 29.56	832.7 32.78	8.0 0.315		170 150	91.60 201.94	
750.000 29.5276	920.000 36.2205	78.000 3.0709	878.000 34.5669	4600 1030000	2080 467000	NCF18/750V	5.0 0.20	5.0 0.20	788.0 31.02	880.0 34.65	8.0 0.315		160 140	105.10 231.20	
800.000 31.4961	980.000 38.5827	82.000 3.2283	935.000 36.8110	4930 1110000	2150 484000	NCF18/800V	5.0 0.20	5.0 0.20	845.0 33.27	937.0 36.89	9.0 0.354		150 130	105.10 231.20	

⁽¹⁾Based on 1 x 10⁶ revolutions L₁₀ life, for the ISO life calculation method.

⁽²⁾The radial internal clearance (RIC) for the bearing assembly must be included when ordering the complete assembly.

⁽³⁾Permissible axial displacement from normal position of one bearing ring in relation to the other.

TWO-ROW

- Additional radial load-carrying capability compared to single-row product.
- Designed to ISO/DIN specified interchangeable dimensions.
- Sold as complete assembly.

Bearing Dimensions				Load Rating		Bearing Part Number ⁽²⁾
Bore d	O.D. D	Width B	DUR/DOR F/E	Static C ₀	Dynamic C ₁ ⁽¹⁾	
mm in.	mm in.	mm in.	mm in.	kN lbf.	kN lbf.	
150.000 5.9055	210.000 8.2677	60.000 2.3622	168.500 6.6339	668 150200	374 84100	NNU4930MAW33
160.000 6.2992	220.000 8.6614	60.000 2.3622	178.500 7.0276	692 155600	380 85300	NNU4932MAW33
170.000 6.6929	230.000 9.0551	60.000 2.3622	188.500 7.4213	696 156200	376 84600	NNU4934MAW33
180.000 7.0866	250.000 9.8425	69.000 2.7165	202.000 7.9528	850 191000	449 101000	NNU4936MAW33
190.000 7.4803	260.000 10.2362	69.000 2.7165	212.000 8.3465	890 200000	459 103000	NNU4938MAW33
200.000 7.8740	280.000 11.0236	80.000 3.1496	225.000 8.8583	1046 234000	550 124000	NNU4940MAW33
200.000 7.8740	340.000 13.3858	140.000 5.5118	235.000 9.2520	2460 552000	1690 381000	NNU4140MAW33
220.000 8.6614	300.000 11.8110	80.000 3.1496	245.000 9.6457	1150 258000	577 130000	NNU4944MAW33
220.000 8.6614	370.000 14.5669	150.000 5.9055	258.000 10.1575	2960 666000	1930 434000	NNU4144MAW33
240.000 9.4488	320.000 12.5984	80.000 3.1496	265.000 10.4331	1220 274000	591 133000	NNU4948MAW33
240.000 9.4488	400.000 15.7480	160.000 6.2992	282.000 11.1024	3680 828000	2290 515000	NNU4148MAW33
260.000 10.2362	360.000 14.1732	100.000 3.9370	292.000 11.4961	1710 385000	856 192000	NNU4952MAW33
260.000 10.2362	440.000 17.3228	180.000 7.0866	306.000 12.0472	4540 1022000	2840 639000	NNU4152MAW33
280.000 11.0236	380.000 14.9606	100.000 3.9370	312.000 12.2835	1834 412000	880 1980	NNU4956MAW33
280.000 11.0236	460.000 18.1102	180.000 7.0866	326.000 12.8346	4820 1084000	2940 660000	NNU4156MAW33
300.000 11.8110	420.000 16.5354	118.000 4.6457	339.000 13.3465	2380 536000	1170 263000	NNU4960MAW33

⁽¹⁾ Based on 1 x 10⁶ revolutions L₁₀ life, for the ISO life calculation method.

⁽²⁾ The radial internal clearance (RIC) for the bearing assembly must be included when ordering the complete assembly.

⁽³⁾ Permissible axial displacement from normal position of one bearing ring in relation to the other.

NNU-1

- Outer rings with solid ribs.
- Lubrication grooves and holes on outer rings.
- One solid brass cage.

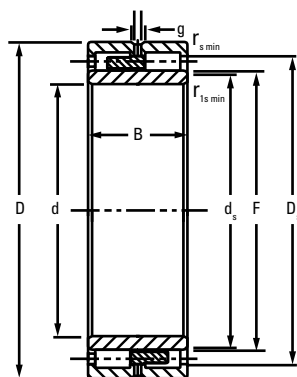

NNU-1

Mounting Data				Lubrication Data				Geometry Factor C _g	Thermal Speed Ratings		Weight
Chamfer		Backing Diameter		Groove g	Hole Dia. h	Number of Holes z	s ⁽³⁾		Oil RPM	Grease RPM	
r _{smin}	r _{1smin}	Shaft d _s	Housing D _s					mm in.			mm in.
2.0 0.08	2.0 0.08	165.0 6.50	197.0 7.76	6.8 0.27	3 0.12	6	2.6 0.10	0.199	2100	1800	6.30 13.90
2.0 0.08	2.0 0.08	175.0 6.89	207.0 8.15	6.8 0.27	3 0.12	6	2.8 0.11	0.206	2000	1700	6.60 14.60
2.0 0.08	2.0 0.08	185.0 7.28	217.0 8.54	6.8 0.27	3 0.12	6	2.8 0.11	0.161	1900	1600	7.00 15.40
2.0 0.08	2.0 0.08	198.0 7.80	232.0 9.13	9.6 0.38	4.5 0.18	6	3.4 0.13	0.136	1700	1500	10.50 23.10
2.0 0.08	2.0 0.08	207.0 8.15	242.0 9.53	9.6 0.38	4.5 0.18	6	2.0 0.08	0.141	1600	1400	10.80 23.80
2.1 0.08	2.1 0.08	220.0 8.66	259.0 10.20	12.3 0.48	6 0.24	6	3.9 0.15	0.147	1500	1300	15.00 33.10
3.0 0.12	3.0 0.12	229.0 9.02	315.0 12.40	12.3 0.48	6 0.24	6	5.40 0.21	0.165	1200	1100	51.00 112.00
2.1 0.08	2.1 0.08	240.0 9.45	279.0 10.98	12.3 0.48	6 0.24	6	3.9 0.15	0.157	1400	1200	16.50 36.40
4.0 0.16	4.0 0.16	251.0 9.88	342.0 13.46	12.3 0.48	6 0.24	6	5.6 0.22	0.180	1000	940	65.00 143.00
2.1 0.08	2.1 0.08	260.0 10.24	299.0 11.77	12.3 0.48	6 0.24	6	3.9 0.15	0.165	1200	1100	17.50 38.60
4.0 0.16	4.0 0.16	275.0 10.83	368.0 14.49	12.3 0.48	6 0.24	6	7.2 0.28	0.196	870	800	85.00 187.40
2.1 0.08	2.1 0.08	287.8 11.33	334.0 13.15	16.0 0.63	7.5 0.30	6	4.4 0.17	0.181	1100	950	30.30 66.80
4.0 0.16	4.0 0.16	298.9 11.77	402.0 15.83	16.0 0.63	7.5 0.30	6	6.3 0.41	0.210	760	710	112.00 247.00
2.1 0.08	2.1 0.08	304.5 11.99	354.0 13.94	16.0 0.63	7.5 0.30	6	4.8 0.19	0.190	1000	880	32.50 71.60
5.0 0.20	5.0 0.20	318.9 12.56	422.0 16.61	16.0 0.63	7.5 0.29	8	6.3 0.28	0.219	990	910	119.00 262.00
3.0 0.12	3.0 0.12	330.4 13.01	389.0 15.31	19.3 0.76	9.5 0.37	8	5.3 0.21	0.205	880	780	50.00 110.00

Continued on next page.

TWO-ROW – continued

Bearing Dimensions				Load Rating		Bearing Part Number ⁽²⁾
Bore d	O.D. D	Width B	DUR/DOR F/E	Static C ₀	Dynamic C ₁ ⁽¹⁾	
mm in.	mm in.	mm in.	mm in.	kN lbf.	kN lbf.	
300.000 11.8110	500.000 19.6850	200.000 7.8740	351.000 13.8189	6140 1382000	3780 850000	NNU4160MAW33
320.000 12.5984	440.000 17.3228	118.000 4.6457	359.000 14.1339	2660 598000	1270 285000	NNU4964MAW33
320.000 12.5984	540.000 21.2598	218.000 8.5827	375.000 14.7638	6280 1410000	3940 886000	NNU4164MAW33
340.000 13.3858	460.000 18.1102	118.000 4.6457	379.000 14.9213	2660 598000	1250 282000	NNU4968MAW33
340.000 13.3858	520.000 20.4724	180.000 7.0866	385.000 15.1575	5130 1153000	2980 669000	NNU4068MAW33
340.000 13.3858	580.000 22.8346	243.000 9.5669	402.000 15.8268	7580 1704000	4660 1050000	NNU4168MAW33
360.000 14.1732	480.000 18.8976	118.000 4.6457	399.000 15.7087	2800 630000	1270 285000	NNU4972MAW33
360.000 14.1732	540.000 21.2598	180.000 7.0866	405.000 15.9449	5580 1256000	3180 716000	NNU4072MAW33
360.000 14.1732	600.000 23.6220	243.000 9.5669	422.000 16.6142	8480 1906000	5000 1120000	NNU4172MAW33
380.000 14.9606	520.000 20.4724	140.000 5.5118	426.000 16.7717	3720 836000	1660 373000	NNU4976MAW33
380.000 14.9606	560.000 22.0472	180.000 7.0866	425.000 16.7323	5860 1316000	3260 733000	NNU4076MAW33
380.000 14.9606	620.000 24.4094	243.000 9.5669	442.000 17.4016	8520 1916000	4990 1120000	NNU4176MAW33
400.000 15.7480	540.000 21.2598	140.000 5.5118	446.000 17.5591	3920 882000	1710 384000	NNU4980MAW33
400.000 15.7480	600.000 23.6220	200.000 7.8740	449.000 17.6772	7210 1621000	3970 893000	NNU4080MAW33
400.000 15.7480	650.000 25.5906	250.000 9.8425	463.000 18.2283	9460 2120000	5530 1240000	NNU4180MAW33
420.000 16.5354	560.000 22.0472	140.000 5.5118	466.000 18.3465	4140 928000	1750 394000	NNU4984MAW33
420.000 16.5354	620.000 24.4094	200.000 7.8740	469.000 18.4646	7600 1706000	4070 914000	NNU4084MAW33
420.000 16.5354	700.000 27.5591	280.000 11.0236	497.000 19.5669	11420 2560000	6430 1450000	NNU4184MAW33
440.000 17.3228	600.000 23.6220	160.000 6.2992	490.000 19.2913	5740 1292000	2500 562000	NNU4988MAW33
440.000 17.3228	650.000 25.5906	212.000 8.3465	487.000 19.1732	8180 1840000	4530 1020000	NNU4088MAW33
440.000 17.3228	720.000 28.3465	280.000 11.0236	511.000 20.1181	11400 2560000	6620 1490000	NNU4188MAW33

⁽¹⁾ Based on 1 x 10⁶ revolutions L₁₀ life, for the ISO life calculation method.

⁽²⁾ The radial internal clearance (RIC) for the bearing assembly must be included when ordering the complete assembly.

⁽³⁾ Permissible axial displacement from normal position of one bearing ring in relation to the other.

Mounting Data				Lubrication Data				Geometry Factor C _g	Thermal Speed Ratings		Weight
Chamfer		Backing Diameter		Groove g	Hole Dia. h	Number of Holes z	s ⁽³⁾		Oil	Grease	
r _{smin}	r _{1smin}	Shaft d _s	Housing D _s								
mm in.	mm in.	mm in.	mm in.	mm in.	mm in.	mm in.				kg lbs.	
5.0 0.20	5.0 0.20	343.0 13.50	463.0 18.23	12.0 0.47	6 0.24	8	6.5 0.26	0.236	600	560	158.00 348.00
3.0 0.12	3.0 0.12	351.0 13.82	409.0 16.10	10.0 0.39	5.0 0.20	8	5.2 0.20	0.216	790	710	54.00 119.00
5.0 0.20	5.0 0.20	365.0 14.37	495.0 19.49	19.3 0.76	9.5 0.37	10	8.8 0.35	0.242	590	550	200.00 441.00
3.0 0.12	3.0 0.12	380.0 14.96	487.0 19.17	19.3 0.76	9.5 0.37	8	6.3 0.25	0.222	760	670	56.00 123.00
5.0 0.20	5.0 0.20	380.0 14.96	487.0 19.17	19.3 0.76	9.5 0.37	10	8.9 0.35	0.238	610	560	140.00 309.00
5.0 0.20	5.0 0.20	391.0 15.39	530.0 20.87	19.3 0.76	9.5 0.37	10	9.6 0.38	0.258	530	490	260.00 573.00
3.0 0.12	3.0 0.12	392.0 15.43	449.0 17.68	19.3 0.76	9.5 0.37	8	5.6 0.33	0.229	710	630	58.50 129.00
5.0 0.20	5.0 0.20	400.0 15.75	507.0 19.96	19.3 0.76	9.5 0.37	10	7.9 0.33	0.248	560	510	140.00 309.00
5.0 0.20	5.0 0.20	408.0 16.06	550.0 21.65	19.3 0.76	9.5 0.37	10	9.2 0.36	0.271	470	440	275.00 606.00
4.0 0.16	4.0 0.16	418.0 16.46	482.0 18.98	19.30 0.76	9.50 0.37	10	6.6 0.26	0.248	630	560	87.50 193.00
5.0 0.20	5.0 0.20	415.00 16.34	525.00 20.67	19.30 0.76	9.50 0.37	10	7.90 0.31	0.256	530	480	150.00 331.00
5.0 0.20	5.0 0.20	429.0 16.89	570.0 22.44	19.30 0.76	9.50 0.37	10	9.2 0.36	0.277	460	430	285.00 628.00
4.0 0.16	4.0 0.16	437.0 17.20	504.0 19.84	19.30 0.76	9.50 0.37	10	7.1 0.28	0.257	600	530	91.70 202.00
5.0 0.20	5.0 0.20	440.0 17.32	560.0 22.05	19.30 0.76	9.50 0.37	10	8.2 0.32	0.274	460	430	205.00 452.00
6.0 0.24	6.0 0.24	451.4 17.77	599.0 23.58	19.30 0.76	9.50 0.37	12	9.3 0.37	0.288	410	390	325.00 716.00
4.0 0.16	4.0 0.16	456.4 17.97	522.0 20.55	19.30 0.76	9.50 0.37	10	5.9 0.23	0.265	560	500	98.00 216.00
5.0 0.20	5.0 0.20	459.0 18.07	577.0 22.72	19.30 0.76	9.50 0.37	10	8.40 0.33	0.282	430	400	183.00 403.00
6.0 0.24	6.0 0.24	490.0 19.29	647.0 25.47	19.30 0.76	9.50 0.37	12	9.3 0.37	0.309	370	350	440.00 970.00
4.0 0.16	4.0 0.16	480.4 18.91	558.0 21.97	16.00 0.63	8.00 0.31	10	6.8 0.27	0.286	460	420	136.00 300.00
6.0 0.24	6.0 0.24	478.0 18.82	607.0 23.90	19.30 0.76	9.50 0.37	12	8.80 0.35	0.290	410	380	215.00 474.00
6.0 0.24	6.0 0.24	497.4 19.58	661.0 26.02	25.3 1.00	13.0 0.51	12	11.0 0.43	0.311	370	340	119.00 262.00

Continued on next page.

TWO-ROW – continued

Bearing Dimensions				Load Rating		Bearing Part Number ⁽²⁾
Bore d	O.D. D	Width B	DUR/DOR F/E	Static C ₀	Dynamic C ₁ ⁽¹⁾	
mm in.	mm in.	mm in.	mm in.	kN lbf.	kN lbf.	
460.000 18.1102	620.000 24.4094	160.000 6.2992	510.000 20.0787	5540 1246000	2420 544000	NNU4992MAW33
460.000 18.1102	680.000 26.7717	218.000 8.5827	513.000 20.1969	9420 2120000	4980 1120000	NNU4092MAW33
460.000 18.1102	760.000 29.9213	300.000 11.8110	537.000 21.1417	12960 2920000	7440 1670000	NNU4192MAW33
480.000 18.8976	650.000 25.5906	170.000 6.6929	534.000 21.0236	6160 1382000	2680 602000	NNU4996MAW33
480.000 18.8976	700.000 27.5591	218.000 8.5827	533.000 20.9843	9730 2189000	5090 1150000	NNU4096MAW33
480.000 18.8976	790.000 31.1024	308.000 12.1260	557.000 21.9291	14260 3200000	8190 1840000	NNU4196MAW33
500.000 19.6850	670.000 26.3780	170.000 6.6929	554.000 21.8110	6280 1410000	2690 605000	NNU49/500MAW33
500.000 19.6850	720.000 28.3465	218.000 8.5827	553.000 21.7717	10560 2380000	5550 1250000	NNU40/500MAW33
530.000 20.8661	710.000 27.9528	180.000 7.0866	588.000 23.1496	8180 1839000	3360 755000	NNU49/530MAW33
530.000 20.8661	780.000 30.7087	250.000 9.8425	591.000 23.2677	12160 2740000	6330 1420000	NNU40/530MAW33
560.000 22.0472	750.000 29.5276	190.000 7.4803	623.000 24.5276	8780 1976000	3590 808000	NNU49/560MAW33
600.000 23.6220	800.000 31.4961	200.000 7.8740	666.000 26.2205	10120 2280000	4040 907000	NNU49/600MAW33
630.000 24.8031	850.000 33.4646	218.000 8.5827	704.000 27.7165	11520 2580000	4570 1030000	NNU49/630MAW33
670.000 26.3780	900.000 35.4331	230.000 9.0551	738.000 29.0551	13460 3020000	5430 1220000	NNU49/670MAW33
670.000 26.3780	980.000 38.5827	308.000 12.1260	744.000 29.2913	18840 4236000	9740 2190000	NNU40/670MAW33
710.000 27.9528	950.000 37.4016	243.000 9.5669	782.000 30.7874	14660 3300000	6310 1420000	NNU49/710MAW33
750.000 29.5276	1000.000 39.3701	250.000 9.8425	831.000 32.7165	16480 3700000	6230 1400000	NNU49/750MAW33
800.000 31.4961	1060.000 41.7323	258.000 10.1575	880.000 34.6457	17390 3909000	7070 1590000	NNU49/800MAW33
850.000 33.4646	1120.000 44.0945	272.000 10.7087	939.000 36.9685	17900 4020000	6810 1530000	NNU49/850MAW33
900.000 35.4331	1180.000 46.4567	280.000 11.0236	986.000 38.8189	20650 4643000	7790 1750000	NNU49/900MAW33

⁽¹⁾Based on 1 x 10⁶ revolutions L₁₀ life, for the ISO life calculation method.

⁽²⁾The radial internal clearance (RIC) for the bearing assembly must be included when ordering the complete assembly.

⁽³⁾Permissible axial displacement from normal position of one bearing ring in relation to the other.

Mounting Data				Lubrication Data				Geometry Factor C _g	Thermal Speed Ratings		Weight
Chamfer		Backing Diameter		Groove g	Hole Dia. h	Number of Holes z	s ⁽³⁾		Oil	Grease	
r _{smin}	r _{1smin}	Shaft d _s	Housing D _s								
mm in.	mm in.	mm in.	mm in.	mm in.	mm in.	mm in.				kg lbs.	
4.0 0.16	4.0 0.16	500.0 19.69	578.0 22.76	19.3 0.76	9.5 0.37	10	6.2 0.24	0.288	460	420	135.00 298.00
6.0 0.24	6.0 0.24	502.0 19.76	633.0 24.92	19.30 0.76	9.50 0.37	12	8.40 0.33	0.305	370	340	240.00 529.00
7.5 0.30	7.5 0.30	525.0 20.67	697.0 27.44	19.30 0.76	9.50 0.37	12	11.3 0.44	0.324	330	320	535.00 1179.00
5.0 0.20	5.0 0.20	526.0 20.71	606.0 23.86	19.30 0.76	9.50 0.37	12	6.8 0.27	0.299	430	390	160.00 353.00
6.0 0.24	6.0 0.24	527.0 20.75	653.0 25.71	19.3 0.76	9.5 0.37	12	8.7 0.34	0.313	350	330	275.00 606.00
7.5 0.30	7.5 0.30	543.0 21.38	727.0 28.62	25.3 1.00	13.0 0.51	12	12.0 0.47	0.335	310	290	590.00 1301.00
5.0 0.20	5.0 0.20	543.0 21.38	626.0 24.65	19.3 0.76	9.5 0.37	12	6.4 0.25	0.306	420	380	170.00 375.00
6.0 0.24	6.0 0.24	544.0 21.42	681.0 26.81	16.0 0.63	7.5 0.30	12	7.7 0.30	0.322	330	310	288.00 635.00
5.0 0.20	5.0 0.20	577.7 22.74	664.0 26.14	19.3 0.76	9.5 0.37	12	6.3 0.25	0.334	350	320	207.00 456.00
6.0 0.24	6.0 0.24	579.3 22.81	727.0 28.62	19.30 0.76	9.50 0.37	12	11.00 0.43	0.341	300	280	420.00 925.93
5.0 0.20	5.0 0.20	612.0 24.09	703.0 27.68	22.0 0.87	12.0 0.47	12	6.6 0.26	0.346	330	300	245.00 540.00
5.0 0.20	5.0 0.20	655.0 25.79	750.0 29.53	25.3 1.00	13.0 0.51	12	6.9 0.27	0.365	290	270	294.00 648.00
6.0 0.24	6.0 0.24	691.0 27.20	794.0 31.26	25.3 1.00	13.0 0.51	16	9.4 0.37	0.383	270	250	365.00 804.70
6.0 0.24	6.0 0.24	726.9 28.62	838.0 32.99	19.3 0.76	9.5 0.37	16	8.4 0.33	0.400	240	230	428.00 944.00
7.5 0.30	7.5 0.30	726.9 28.62	922.0 36.30	22.0 0.87	12.0 0.47	16	13.0 0.51	0.404	210	200	769.00 1695.00
6.0 0.24	6.0 0.24	767.3 30.21	902.1 35.52	19.3 0.76	9.5 0.37	16	10.7 0.42	0.409	220	210	488.00 1076.00
6.0 0.24	6.0 0.24	817.9 32.20	933.0 36.73	19.3 0.76	9.5 0.37	16	7.6 0.30	0.442	200	190	568.00 1252.20
6.0 0.24	6.0 0.24	865.4 34.07	1000.0 39.37	19.3 0.76	9.5 0.37	16	10.5 0.41	0.450	190	180	598.00 1318.00
6.0 0.24	6.0 0.24	928.0 36.54	1047.0 41.22	25.3 1.00	13 0.51	16	16.0 0.63	0.470	190	170	360.00 794.00
6.0 0.24	6.0 0.24	968.8 38.14	1106.0 43.54	25.3 1.00	13 0.51	16	11.9 0.47	0.494	160	150	839.00 1850.00

FOUR-ROW CYLINDRICAL ROLLER BEARINGS

Timken's four-row cylindrical roller bearings are designed for the rigors of daily use in applications where moderate and high speeds, high radial loads, elevated temperatures and debris are constant challenges. Designed with well-balanced cross sections, these bearings provide high-radial-load capacity within the bearing envelope.

APPLICATIONS

Engineered primarily for rolling mill roll-neck applications, Timken's four-row cylindrical bearings are commonly used in work roll or back-up roll positions in flat product, long product and structural mills.

Product Features

- Available in sizes 140 mm I.D. – 2000 mm O.D. (5.512 in. – 78.740 in.).
- Case-hardened rings and rollers enhance durability.
- Inner races are interchangeable with outer assemblies.
- Manufactured to P6 boundary and P5 runout tolerances.
- Roller profiles are custom designed and manufactured for optimum performance.
- Straight and tapered bores are available.



Fig. 21. Four-row cylindrical roller bearing.

DESIGN BENEFITS

Our most common configurations available are types RY, RYL and RX. However, Timken also will custom design and manufacture bearings for your particular size and application requirements. If you have a new mill application, our engineers will work with you in the earliest design stages to help you select the right bearings.

RADIAL INTERNAL CLEARANCE (RIC)

Timken's standard bearings offer different clearances, such as C3 or C4 according to DIN 620-4. If needed for your application, they can be furnished with a tapered bore.

Timken supplies inner rings in two ways: a finished state with no additional grinding required or a semi-finished condition with appropriate grind stock. Semi-finished inner rings allow mill operators to optimize the roll's precision by finish grinding the inner ring after mounting it onto the roll.

The part numbers for these bearings and inner-ring assemblies are identified by a CF suffix.

LUBRICATION

Timken four-row cylindrical roller bearings can be used with grease, oil-air, oil-mist or circulating-oil systems. The bearings must be correctly lubricated for maximum performance through either lubrication grooves, holes in the outer-ring O.D. or through integrated face slots on the outer-ring faces. See detailed design types on pages 84-87 for further information on the standard lubrication configurations by bearing type.

MATERIAL

Our bearings are designed to provide superior size stability, fracture toughness and reliability. By using only high quality, carburized alloy, and applying a special heat-treatment during the manufacturing process, we are able to produce bearings that can withstand the heavy stresses and impact loading often experienced by multi-row cylindrical roller bearings used in rolling mills.

MOUNTING DESIGN AND FITTING PRACTICE

The cylindrical roller bearing design accommodates radial loading only, therefore, a separate thrust bearing must be used to provide axial shaft location.

The housing fitting practice usually results in a loose fit to facilitate easy removal at regular maintenance intervals. The preferred shaft fit is tight. There are occasions where loose shaft fits are tolerated, such as on some roughing-mill equipment. In the cases where a shaft fit is loose, inner-race bore lubrication grooves must be incorporated in the bearing. Check with your Timken engineer for a more details on mounting four-row cylindrical roller bearings. Mounting information also is available in the Timken Engineering Manual (order no. 10424) on timken.com/catalogs.

In order to facilitate the dismounting, face slots can be added on the inner rings (W30B modification code).

Inner rings can be ordered separately from the outer assembly in order to equip additional spare rolls. Inner- and outer-ring assemblies are interchangeable in regard to internal clearance.

MAIN DESIGN TYPES

Optimized rolling elements and race geometry provides high radial-load capacity within the bearing envelope. In addition, multiple cage designs and materials allow for design flexibility and preset radial clearance simplifies the installation process.

TYPE RY

The RY bearing style incorporates two outer races with triple flanges (solid ribs). The inner race is usually single-piece construction. The outer assemblies consist of the outer race, rollers and cages, which create a unitized construction. Handling is made simple by this design. A loading slot is used for roller insertion. Lubrication is generally accomplished via slots in the faces of the outer ring. The cage is single-piece, fully machined-brass or steel material. The roller pockets are staggered between the races.

TYPE RX

The RX bearings are four-row construction, having two single-flanged outer races and rib rings for roller spacing. This allows for complete disassembly for inspection. The RX style is usually preferred in bearings above 400 mm bore.

Both brass and pin-type cages are available in this bearing style. Most inners are two-piece assemblies.

TYPE RYL AND RXL

The most recent RYL and RXL designs are available in sizes up to 340 mm bore and specifically designed for long-product mills. Standard steel cage and enhanced design features are included to maximize bearing life, reduce roller drop and optimize bearing handling.

Fig. 22. Four-row bearing nomenclature.

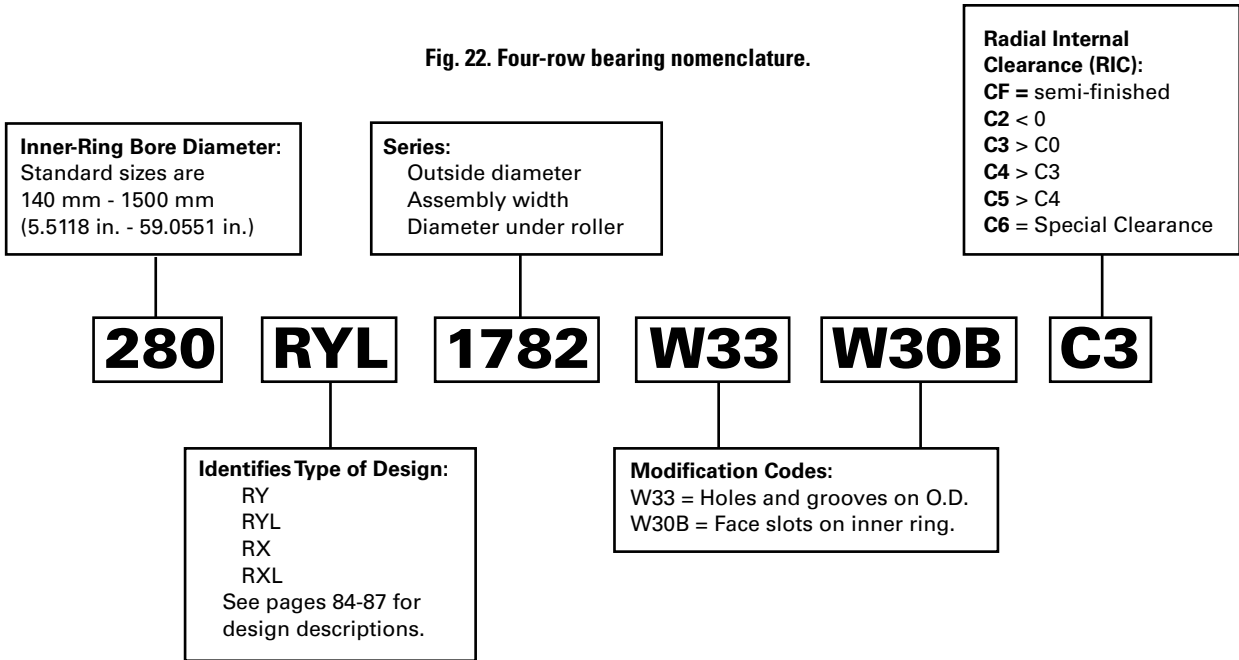

FOUR-ROW DETAILED DESIGN TYPES

RY-1

- Two outer rings with integral ribs.
- One-piece inner ring.
- Lubrication grooves and holes on outer rings.
- Two solid-steel or brass cages.

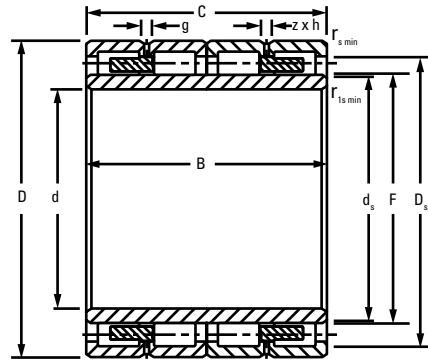

RY-1

RY-2

- Two outer rings with integral ribs.
- Two inner rings.
- RY-2 – with lubrication grooves and holes on outer rings.
- RY-3 – without lubrication grooves and holes on outer rings.
- Two solid-steel or brass cages.

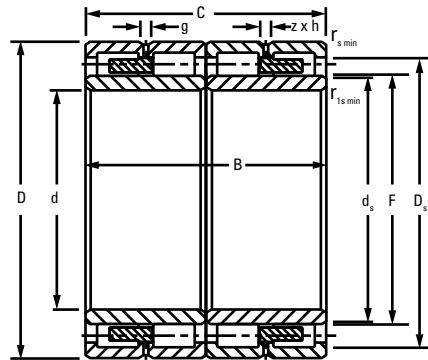

RY-2

RY-4

- Two outer rings with integral ribs.
- Lubrication grooves and holes on outer rings.
- Two inner rings.
- Lubrication grooves and face slots on inner rings.
- RY-4 – extended inner ring on one side.
- RY-5 – extended inner ring on both sides.
- Two solid-steel or brass cages.

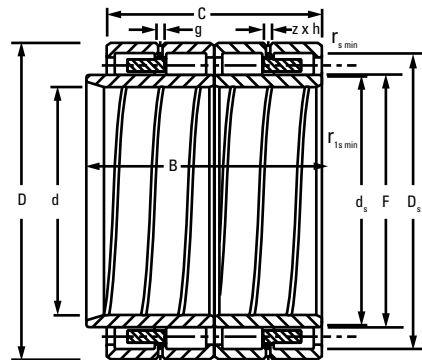

RY-4

RY-6

- Two outer rings with integral ribs.
- One-piece inner ring.
- Face slots on outer rings.
- Two solid-steel cages.

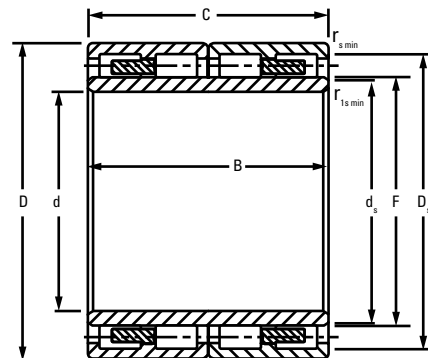

RY-6

RX-1, RX-9 and RX-11

- Two outer rings with three rib rings.
- Two inner rings.
- Four pin-type steel cages.
- RX-1 – with lubrication grooves and holes on outer rings.
- RX-9 – with oil-mist nozzles and O-rings in outer rings.
- RX-11 – with lubrication grooves, holes and O-rings on outer rings.

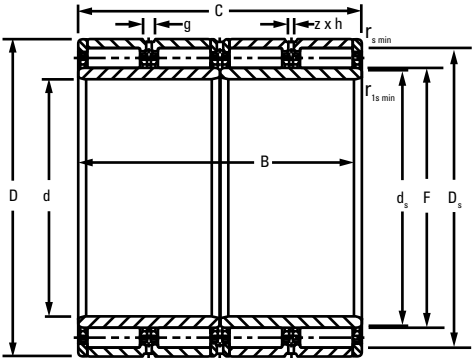

RX-1

RX-2

- Two outer rings with integral ribs.
- Two inner rings.
- Two solid-steel or brass cages.
- Lubrication grooves and holes on outer rings.

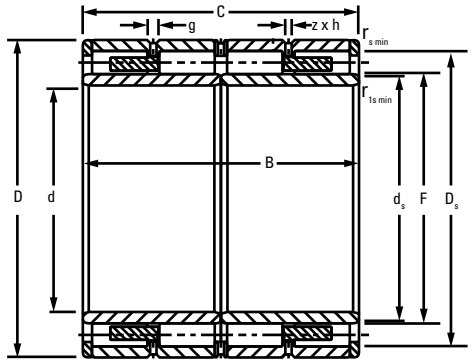

RX-2

RX-3

- Two outer rings with three rib rings.
- Two inner rings.
- Two solid-steel or brass cages.
- Lubrication grooves and face slots on inner rings.
- Lubrication grooves and holes on outer rings.
- Extended inner ring on one side.

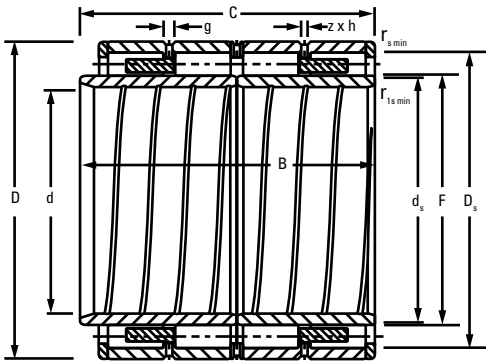

RX-3

RX-4

- Two outer rings with three rib rings.
- Two inner rings.
- Four pin-type steel cages.
- Lubrication grooves and face slots on inner rings.
- Lubrication grooves and holes on outer rings.
- Extended inner ring on one side.

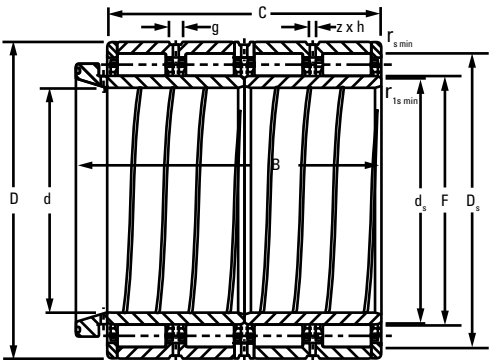

RX-4

RX-5 and RX-6

- Two outer rings with three rib rings.
- Two inner rings.
- Four pin-type steel cages.
- Lubrication grooves and face slots on inner rings.
- Lubrication grooves and holes on outer rings.
- RX-5 – identical width on outer and inner assembly.
- RX-6 – extended inner ring on one side.

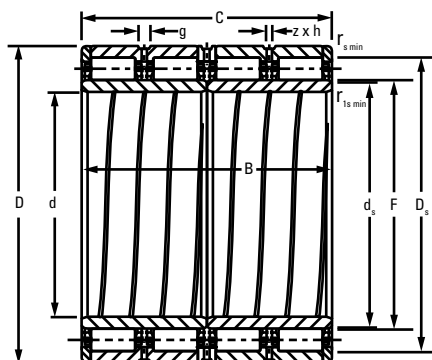

RX-5

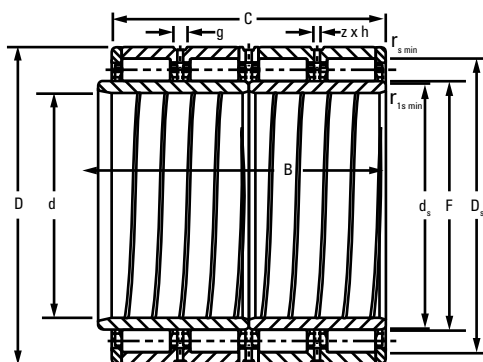

RX-6

RX-7

- Two outer rings with three rib rings.
- Four inner rings.
- Four pin-type steel cages.
- Lubrication grooves and holes on outer rings.

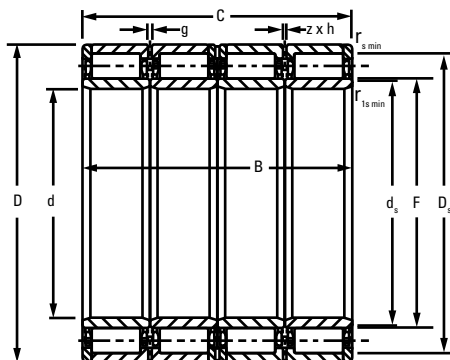

RX-7

RX-8 and RX-10

- Two outer rings with three rib rings.
- Two inner rings.
- Four pin-type steel cages.
- Lubrication grooves and holes on outer rings.
- Extended inner ring on one side.
- RX-10 – with oil-mist nozzles and O-rings in outer rings.

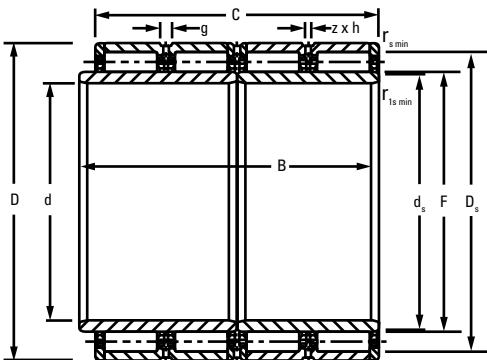

RX-8

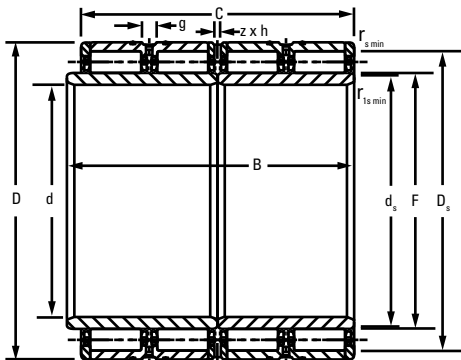

RX-10

RXK-1 and RXK-2

- Two outer rings with three rib rings.
- One-piece tapered bore inner ring.
- Four pin-type steel cages.
- Lubrication grooves and holes on outer rings.
- RXK-1 – with oil-mist nozzles and O-rings in outer rings.

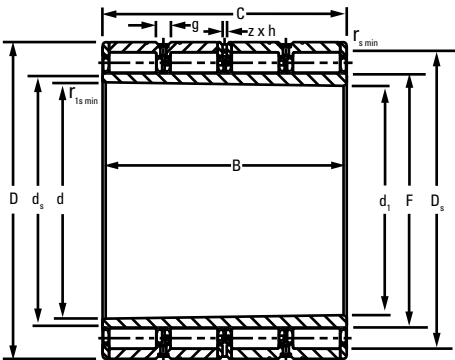

RXK-1

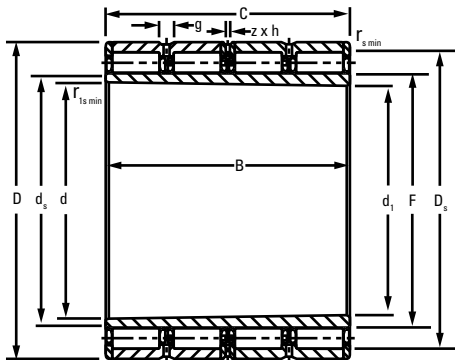

RXK-2

FOUR-ROW CYLINDRICAL ROLLER BEARINGS

Bearing Dimensions					Load Rating		Part Number	
Bore d	O.D. D	Width B	Width C	DUR/DOR F/E	Static C ₀	Dynamic C ₁ ⁽¹⁾	Bearing ⁽²⁾	Type
mm in.	mm in.	mm in.	mm in.	mm in.	kN lbf.	kN lbf.		
145.000 5.7087	225.000 8.8583	156.000 6.1417	156.000 6.1417	169.000 6.6535	1832 412000	1100 248000	145RYL1452	RY-6
160.000 6.2992	230.000 9.0551	130.000 5.1181	130.000 5.1181	180.000 7.0866	1352 30440	856 192400	160RYL1468	RY-6
160.000 6.2992	230.000 9.0551	168.000 6.6142	168.000 6.6142	179.000 7.0472	2224 500000	1188 268000	160RYL1467	RY-6
165.100 6.5000	225.425 8.8750	168.275 6.6250	168.275 6.6250	181.000 7.1260	2264 508000	1158 260000	165RYL1451	RY-3
180.000 7.0866	260.000 10.2362	168.000 6.6142	168.000 6.6142	202.000 7.9528	2568 576000	1452 326000	180RYL1527	RY-6
190.000 7.4803	260.000 10.2362	168.000 6.6142	168.000 6.6142	212.000 8.3465	2604 584000	1288 290000	190RY1528	RY-1
190.000 7.4803	270.000 10.6299	200.000 7.8740	200.000 7.8740	212.000 8.3465	3304 744000	1702 382000	190RY1543	RY-1
200.000 7.8740	270.000 10.6299	170.000 6.6929	170.000 6.6929	222.000 8.7402	2788 628000	1334 300000	200RYL1544	RY-6
200.000 7.8740	280.000 11.0236	170.000 6.6929	170.000 6.6929	222.000 8.7402	2868 644000	1542 346000	200RYL1566	RY-6
200.000 7.8740	280.000 11.0236	200.000 7.8740	200.000 7.8740	222.000 8.7402	3424 768000	1730 388000	200RYL1567	RY-6
200.000 7.8740	290.000 11.4173	192.000 7.5591	192.000 7.5591	226.000 8.8976	3208 720000	1774 398000	200RYL1585	RY-6
220.000 8.6614	310.000 12.2047	192.000 7.5591	192.000 7.5591	246.000 9.6850	3432 772000	1840 414000	220RYL1621	RY-6
220.000 8.6614	340.000 13.3858	218.000 8.5827	218.000 8.5827	257.180 10.1252	4160 932000	2320 522000	220RY1683	RY-1
230.000 9.0551	330.000 12.9921	206.000 8.1102	206.000 8.1102	260.000 10.2362	3988 896000	2120 478000	230RYL1667	RY-6
240.000 9.4488	330.000 12.9921	220.000 8.6614	220.000 8.6614	270.000 10.6299	4320 972000	1924 432000	240RY1668	RY-1
250.000 9.8425	340.000 13.3858	230.000 9.0551	230.000 9.0551	276.000 10.8661	4521 1016000	1952 438800	250RY1681	RY-1
260.000 10.2362	370.000 14.5669	220.000 8.6614	220.000 8.6614	292.000 11.4961	5040 1132000	2580 582000	260RYL1744	RY-6
260.000 10.2362	380.000 14.9606	280.000 11.0236	280.000 11.0236	294.000 11.5748	6280 1412000	3240 728000	260RY1763	RY-2
280.000 11.0236	390.000 15.3543	220.000 8.6614	220.000 8.6614	312.000 12.2835	5200 1176000	2620 590000	280RYL1783	RY-6
280.000 11.0236	390.000 15.3543	275.000 10.8268	275.000 10.8268	308.000 12.1260	7020 1578000	3049 685500	280RYL1782	RY-3
300.000 11.8110	420.000 16.5354	300.000 11.8110	300.000 11.8110	332.000 13.0709	8720 1960000	4140 932000	300RX1846	RX-1
300.000 11.8110	420.000 16.5354	300.000 11.8110	300.000 11.8110	332.000 13.0709	8360 1880000	4080 918000	300RXL1845	RX-2

⁽¹⁾Based on 1×10^6 revolutions L_{10} life, for the ISO life calculation method.

⁽²⁾The radial internal clearance (RIC) for the bearing assembly must be included when ordering either a) the complete assembly or b) with the inner-ring set. It is advisable to order the inner-ring set independent of the outer ring set when the final grind of the inner-ring O.D. is accomplished after mounting on the roll neck.

Sub Assembly Part Numbers		Mounting Data				Lubrication Data			Weight
		Chamfer		Backing Diameter		Groove g	Hole Dia. h	Number of Holes z	
Inner-Ring Set ⁽²⁾	Outer-Ring Set	r _{smin}	r _{1smin}	Shaft d _s	Housing D _s				
		mm in.	mm in.	mm in.	mm in.	mm in.	mm in.	kg lbs.	
145ARVSL1452	169RYSL1452	2.0 0.08	2.0 0.08	164.2 6.46	205.0 8.07	–	–	–	23.00 50.71
160ARVSL1468	180RYSL1468	1.5 0.06	1.5 0.06	174.6 6.87	216.0 8.50	–	–	–	16.80 37.00
160ARVSL1467	179RYSL1467	2.0 0.08	2.0 0.08	174.5 6.87	211.0 8.31	–	–	–	23.10 50.80
165ARYSL1451	181RYSL1451	1.5 0.06	1.5 0.06	176.2 6.94	211.0 8.31	–	–	–	19.60 43.20
180ARVSL1527	202RYSL1527	2.1 0.08	2.1 0.08	196.3 7.73	242.0 9.53	–	–	–	29.70 65.40
190ARVS1528	212RYS1528	2.0 0.08	2.0 0.08	207.2 8.16	244.0 9.61	7.0 0.28	4.0 0.16	8	26.50 58.20
190ARVS1543	212RYS1543	2.1 0.08	2.1 0.08	207.2 8.16	250.0 9.84	9.6 0.38	4.5 0.18	6	37.10 81.79
200ARVSL1544	222RYSL1544	2.1 0.08	2.1 0.08	216.9 8.54	254.0 10.00	–	–	–	27.90 61.51
200ARVSL1566	222RYSL1566	2.1 0.08	2.1 0.08	217.5 8.56	262.0 10.31	–	–	–	32.40 71.20
200ARVSL1567	222RYSL1567	2.1 0.08	2.1 0.08	218.0 8.58	260.0 10.24	–	–	–	39.00 85.98
200ARVSL1585	226RYSL1585	2.1 0.08	2.1 0.08	220.6 8.69	270.0 10.63	–	–	–	41.80 92.10
220ARVSL1621	246RYSL1621	3.0 0.12	3.0 0.12	240.5 9.47	290.0 11.42	–	–	–	45.10 99.30
220ARVS1683	257RYS1683	3.0 0.12	3.0 0.12	251.0 9.88	309.2 12.17	10.0 0.39	5.0 0.20	8	75.60 166.30
230ARVSL1667	260RYSL1667	2.1 0.08	2.1 0.08	253.5 9.98	308.0 12.13	–	–	–	58.30 128.20
240ARVS1668	270RYS1668	2.1 0.08	2.1 0.08	1917.4 75.49	306.0 12.05	9.6 0.38	4.5 0.18	6	56.70 125.00
250ARVS1681	276RYS1681	4.0 0.16	3.5x45° 0.14x45°	269.5 10.61	320.0 12.60	10.0 0.39	5.0 0.20	6	60.30 132.70
260ARVSL1744	292RYSL1744	3.0 0.12	3.0 0.12	285.0 11.22	344.0 13.54	–	–	–	107.60 236.70
260ARYS1763	294RYS1763	3.0 0.12	3.0 0.12	286.5 11.28	350.0 13.78	10.0 0.39	5.0 0.20	6	107.60 236.70
280ARVSL1783	312RYSL1783	4.0 0.16	4.0 0.16	305.2 12.02	364.0 14.33	–	–	–	81.90 180.20
280ARYSL1782	308RYSL1782	2.5 0.10	3.5 0.14	301.8 11.88	364.0 14.33	–	–	–	100.70 221.60
300ARXS1845B	332RXS1846	3.5 0.14	7x20° 0.28x20°	325.1 12.80	392.0 15.43	18.0 0.71	9.0 0.35	8	130.50 287.00
300ARXSL1845	332RXSL1845	3.5 0.14	7x20° 0.28x20°	326.1 12.84	392.0 15.43	12.0 0.47	6.0 0.24	8	131.90 290.10

Continued on next page.

FOUR-ROW CYLINDRICAL ROLLER BEARINGS – continued

Bearing Dimensions					Load Rating		Part Number	
Bore d	O.D. D	Width B	Width C	DUR/DOR F/E	Static C ₀	Dynamic C ₁ ⁽¹⁾	Bearing ⁽²⁾	Type
mm in.	mm in.	mm in.	mm in.	mm in.	kN lbf.	kN lbf.		
300.000 11.8110	500.000 19.6850	360.000 14.1732	360.000 14.1732	354.250 13.9469	10160 2288000	6200 1392000	300RY2002	RY-2
330.000 12.9921	460.000 18.1102	340.000 13.3858	340.000 13.3858	365.000 14.3701	10840 2440000	4980 1120000	330RX1922	RX-1
340.000 13.3858	480.000 18.8976	310.000 12.2047	310.000 12.2047	378.000 14.8819	9640 2164000	4660 1048000	340RX1965A	RX-5
340.000 13.3858	480.000 18.8976	350.000 13.7795	350.000 13.7795	378.000 14.8819	10880 2444000	5180 1162000	340RYL1963	RY-3
370.000 14.5669	520.000 20.4724	380.000 14.9606	380.000 14.9606	409.000 16.1024	14040 3156000	6500 1460000	370RX2045	RX-1
380.000 14.9606	540.000 21.2598	300.000 11.8110	300.000 11.8110	421.000 16.5748	10560 2368000	5420 1218000	380RX2089	RX-1
380.000 14.9606	540.000 21.2598	400.000 15.7480	380.000 14.9606	422.000 16.6142	14360 3228000	6840 1536000	380RX2086A	RX-6
380.000 14.9606	540.000 21.2598	400.000 15.7480	400.000 15.7480	422.000 16.6142	14760 3316000	6900 1552000	380RX2087	RX-1
390.000 15.3543	540.000 21.2598	320.000 12.5984	320.000 12.5984	431.000 16.9685	11440 2576000	5540 1248000	390RX2088	RX-1
390.000 15.3543	550.000 21.6535	400.000 15.7480	400.000 15.7480	432.204 17.0159	13960 3136000	6680 1500000	390RY2103	RY-2
400.000 15.7480	560.000 22.0472	410.000 16.1417	410.000 16.1417	445.000 17.5197	16440 3700000	7460 1676000	400RX2123	RX-1
431.500 16.9882	571.500 22.5000	300.000 11.8110	300.000 11.8110	465.000 18.3071	10600 2388000	5200 1170000	431RX2141	RX-1
440.000 17.3228	620.000 24.4094	450.000 17.7165	450.000 17.7165	487.000 19.1732	20200 4560000	9100 2040000	440RX2245	RX-1
460.000 18.1102	685.000 26.9685	400.000 15.7480	400.000 15.7480	518.000 20.3937	15880 3576000	8780 1972000	460RX2371	RX-1
480.000 18.8976	650.000 25.5906	450.000 17.7165	450.000 17.7165	525.000 20.6693	21960 4920000	9540 2140000	480RX2303B	RX-1
500.000 19.6850	670.000 26.3780	485.000 19.0945	450.000 17.7165	540.000 21.2598	22200 5000000	9520 2140000	500RX2345A	RX-4
500.000 19.6850	710.000 27.9528	480.000 18.8976	480.000 18.8976	558.000 21.9685	23800 5360000	10780 2420000	500RX2422	RX-1
500.000 19.6850	720.000 28.3465	530.000 20.8661	530.000 20.8661	568.000 22.3622	28680 6440000	12440 2800000	500RX2443	RX-1
510.000 20.0787	680.000 26.7717	500.000 19.6850	500.000 19.6850	560.000 22.0472	26040 5840000	10280 2320000	510RX2364	RX-1
510.000 20.0787	730.000 28.7402	520.000 20.4724	520.000 20.4724	569.000 22.4016	27280 6120000	12680 2860000	510RX2461	RX-1
530.000 20.8661	760.000 29.9213	520.000 20.4724	520.000 20.4724	587.000 23.1102	27680 6240000	13080 2940000	530RX2522	RX-1
550.000 21.6535	740.000 29.1339	510.000 20.0787	510.000 20.0787	600.000 23.6220	28400 6400000	11780 2640000	550RX2484	RX-1

⁽¹⁾Based on 1×10^6 revolutions L_{10} life, for the ISO life calculation method.

⁽²⁾The radial internal clearance (RIC) for the bearing assembly must be included when ordering either a) the complete assembly or b) with the inner-ring set. It is advisable to order the inner-ring set independent of the outer ring set when the final grind of the inner-ring O.D. is accomplished after mounting on the roll neck.

Sub Assembly Part Numbers		Mounting Data				Lubrication Data			Weight
		Chamfer		Backing Diameter		Groove g	Hole Dia. h	Number of Holes z	
Inner-Ring Set ⁽²⁾	Outer-Ring Set	r _{smin}	r _{1smin}	Shaft d _s	Housing D _s				
		mm in.	mm in.	mm in.	mm in.	mm in.	mm in.	kg lbs.	
300ARYS2002	354RYS2002	5.0 0.20	5.0 0.20	347.4 13.68	454.3 17.89	18.0 0.71	10.0 0.39	8 288.70 635.10	
330ARXS1922	365RXS1922	2.3 0.09	10.5x20° 0.41x20°	357.1 14.06	429.0 16.89	12.0 0.47	6.0 0.24	8 176.30 387.80	
340ARXS1965A	378RXS1965A	3.0 0.12	7x20° 0.28x20°	370.1 14.57	446.0 17.56	16.0 0.63	7.5 0.30	12 179.20 394.20	
340ARYSL1963	378RYSL1963	3.0 0.12	8x20° 0.32x20°	370.6 14.59	446.0 17.56	–	–	– 201.30 442.90	
370ARXS2045	409RXS2045	1.5 0.06	10x20° 0.39x20°	401 15.79	485.0 19.09	16.0 0.63	7.5 0.30	10 257.00 565.30	
380ARXS2089	421RXS2089	2.0 0.08	10x20° 0.39x20°	413 16.26	505.0 19.88	12.3 0.48	6.0 0.24	16 222.10 488.50	
380ARXS2086A	422RXS2086	4.0 0.16	7x20° 0.28x20°	414 16.30	504.0 19.84	16.0 0.63	7.5 0.30	8 288.30 634.20	
380ARXS2087	422RXS2087	2.0 0.08	10x20° 0.39x20°	412.8 16.25	502.0 19.76	16.0 0.63	8.0 0.31	8 297.80 655.10	
390ARXS2088	431RXS2088	2.0 0.08	10x20° 0.39x20°	422.4 16.63	509.0 20.04	15.0 0.59	7.5 0.30	16 223.80 492.40	
390ARYS2103	432RYS2103	4.0 0.16	11x20° 0.43x20°	423.1 16.66	512.2 20.17	16.0 0.63	8.0 0.31	10 304.50 669.90	
400ARXS2123	445RXS2123	4 0.16	12x20° 0.47x20°	436 17.17	525.0 20.67	16.0 0.63	7.5 0.30	10 319.90 703.70	
431ARXS2141	465RXS2141	4 0.16	10.5x20° 0.41x20°	456.4 17.97	545.0 21.46	18.0 0.71	9.0 0.35	8 197.10 434.50	
440ARXS2245	487RXS2245	4 0.16	12x20° 0.47x20°	477.4 18.80	577.0 22.72	16.0 0.63	7.5 0.30	8 438.80 965.30	
460ARXS2371	518RXS2371	3 0.12	11x20° 0.43x20°	508.4 20.02	638.0 25.12	18.0 0.71	9.0 0.35	12 530.50 1167.10	
480ARXS2303B	525RXS2303	5 0.20	12.7x20° 0.50x20°	514.5 20.26	615.0 24.21	18.0 0.71	9.0 0.35	12 433.40 953.40	
500ARXS2345A	540RXS2345	5 0.20	12.5x20° 0.49x20°	531 20.91	630.0 24.80	19.3 0.76	9.5 0.37	12 457.80 1007.30	
500ARXS2422	558RXS2422	6 0.24	18x20° 0.71x20°	545.7 21.48	662.0 26.06	22.0 0.87	12.0 0.47	12 617.20 1357.90	
500ARXS2443	568RXS2443	5 0.20	13x20° 0.51x20°	556.6 21.91	672.0 26.46	22.0 0.87	12.0 0.47	16 737.30 1622.00	
510ARXS2364	560RXS2364	5 0.20	14x20° 0.551x20°	549.7 21.64	644.0 25.35	19.3 0.76	9.5 0.37	12 514.60 1132.20	
510ARXS2461	569RXS2461	6 0.24	17.50x20° 0.69x20°	556.7 21.92	685.0 26.97	19.3 0.76	9.5 0.37	12 750.00 1653.45	
530ARXS2522	587RXS2522	5 0.20	12x20° 0.47x20°	576 22.68	707.0 27.83	19.3 0.76	9.5 0.37	12 787.20 1731.80	
550ARXS2484	600RXS2484	2 0.08	15x20° 0.59x20°	588.5 23.17	698.0 27.48	22.0 0.87	12.0 0.47	16 631.70 1389.70	

Continued on next page.

FOUR-ROW CYLINDRICAL ROLLER BEARINGS – continued

Bearing Dimensions					Load Rating		Part Number	
Bore d	O.D. D	Width B	Width C	DUR/DOR F/E	Static C ₀	Dynamic C ₁ ⁽¹⁾	Bearing ⁽²⁾	Type
mm in.	mm in.	mm in.	mm in.	mm in.	kN lbf.	kN lbf.		
560.000 22.0472	820.000 32.2835	600.000 23.6220	600.000 23.6220	625.000 24.6063	34240 7720000	16180 3640000	560RX2644	RX-1
571.100 22.4843	812.970 32.0067	594.000 23.3858	594.000 23.3858	636.000 25.0394	35000 7880000	15440 3480000	571RX2622	RX-1
600.000 23.6220	820.000 32.2835	575.000 22.6378	575.000 22.6378	660.000 25.9843	36120 8120000	14780 3320000	600RX2643A	RX-1
600.000 23.6220	820.000 32.2835	575.000 22.6378	575.000 22.6378	660.000 25.9843	36120 8120000	14780 3320000	600RX2643B	RX-9
600.000 23.6220	870.000 34.2520	640.000 25.1969	640.000 25.1969	672.000 26.4567	40000 9000000	18040 4060000	600RX2744	RX-1
650.000 25.5906	900.000 35.4331	650.000 25.5906	650.000 25.5906	704.000 27.7165	41200 9280000	18980 4260000	650RX2803A	RX-1
650.000 25.5906	920.000 36.2205	670.000 26.3780	670.000 26.3780	723.000 28.4646	45600 10240000	19520 4380000	650RX2841C	RX-1
690.000 27.1654	980.000 38.5827	715.000 28.1496	715.000 28.1496	767.500 30.2165	53200 11960000	22400 5040000	690RX2965	RX-1
690.000 27.1654	980.000 38.5827	750.000 29.5276	750.000 29.5276	766.000 30.1575	54800 12320000	23000 5160000	690RX2966	RX-9
700.000 27.5591	930.000 36.6142	620.000 24.4094	620.000 24.4094	763.000 30.0394	44400 10000000	16920 380000	700RX2862	RX-1
700.000 27.5591	980.000 38.5827	700.000 27.5591	700.000 27.5591	774.000 30.4724	51200 11520000	21000 4720000	700RX2964A	RX-1
705.000 27.7559	1066.905 42.0041	635.000 25.0000	635.000 25.0000	796.000 31.3386	45200 10120000	22600 5100000	705RX3131B	RX-1
710.000 27.9528	1000.000 39.3701	715.000 28.1496	715.000 28.1496	787.500 31.0039	54400 12240000	22800 5120000	710RX3006	RX-1
730.000 28.7402	960.000 37.7953	620.000 24.4094	620.000 24.4094	790.000 31.1024	45200 10120000	17500 3940000	730RX2922	RX-1
730.000 28.7402	1030.000 40.5512	750.000 29.5276	750.000 29.5276	809.000 31.8504	59200 13280000	24600 5520000	730RX3064	RX-1
730.000 28.7402	1030.000 40.5512	750.000 29.5276	750.000 29.5276	809.000 31.8504	59200 13280000	24600 5520000	730RX3064A	RX-11
750.000 29.5276	1000.000 39.3701	670.000 26.3780	670.000 26.3780	813.000 32.0079	52000 11680000	20400 4580000	750RX3005	RX-1
760.000 29.9213	1080.000 42.5197	790.000 31.1024	790.000 31.1024	846.000 33.3071	63600 14320000	26800 6040000	760RX3166	RX-1
760.925 29.9577	1079.600 42.5039	787.400 31.0000	787.400 31.0000	846.000 33.3071	64000 14440000	26800 6040000	761RX3166B	RX-1
761.425 29.9774	1079.600 42.5039	787.400 31.0000	787.400 31.0000	846.000 33.3071	64000 14440000	26800 6040000	761RX3166	RX-1
770.000 30.3150	1075.000 42.3228	770.000 30.3150	770.000 30.3150	847.000 33.3465	62800 14160000	26000 5860000	770RX3151	RX-1
780.000 30.7087	1070.000 42.1260	780.000 30.7087	780.000 30.7087	853.000 33.5827	62400 14040000	25400 5720000	780RX3141	RX-1

⁽¹⁾Based on 1 x 10⁶ revolutions L₁₀ life, for the ISO life calculation method.

⁽²⁾The radial internal clearance (RIC) for the bearing assembly must be included when ordering either a) the complete assembly or b) with the inner-ring set. It is advisable to order the inner-ring set independent of the outer ring set when the final grind of the inner-ring O.D. is accomplished after mounting on the roll neck.

Sub Assembly Part Numbers		Mounting Data				Lubrication Data			Weight
		Chamfer		Backing Diameter		Groove g	Hole Dia. h	Number of Holes z	
Inner-Ring Set ⁽²⁾	Outer-Ring Set	r _{smin}	r _{1smin}	Shaft d _s	Housing D _s				
		mm in.	mm in.	mm in.	mm in.	mm in.	mm in.	kg lbs.	
560ARXS2644	625RXS2644	6 0.24	20x20° 0.79x20°	611.4 24.07	761.0 29.96	25.3 1.00	13.0 0.51	16 1095.40 2409.90	
571ARXS2622	636RXS2622	5 0.20	14x20° 0.55x20°	623.3 24.54	758.0 29.84	25.3 1.00	13.0 0.51	16 1009.30 2220.40	
600ARXS2643	660RXS2643A	3 0.12	15x20° 0.59x20°	648.3 25.52	770.0 30.31	22.0 0.87	12.0 0.47	16 925.00 2035.00	
600ARXS2643	660RXS2643B	3 0.12	15x20° 0.59x20°	648.3 25.52	770.0 30.31	32.0 1.26	2x1.70 2x0.067	8 923.70 2032.20	
600ARXS2744	672RXS2744	7.5 0.30	20x20° 0.79x20°	658.3 25.92	808.0 31.81	19.3 0.76	9.5 0.37	16 1312.00 2891.90	
650ARXS2803	704RXS2803	7.5 0.30	20x20° 0.79x20°	686.9 27.04	850.0 33.46	22.0 0.87	12.0 0.47	16 1244.90 2738.70	
650ARXS2841	723RXS2841	4 0.16	18x20° 0.71x20°	705.9 27.79	859.0 33.82	25.3 1.00	13.0 0.51	16 1458.30 3208.20	
690ARXS2965	768RXS2965	4 0.16	20x20° 0.79x20°	750.4 29.54	911.5 35.89	25.3 1.00	13.0 0.51	16 1781.40 3919.00	
690ARXS2966	766RXS2966	7.5 0.30	20x20° 0.79x20°	749.6 29.51	910.0 35.83	46.0 1.81	2x1.70 2x0.067	12 1854.10 4079.10	
700ARXS2862	763RXS2862	3 0.12	18x20° 0.71x20°	745.9 29.37	875.0 34.45	22.0 0.87	12.0 0.47	16 1188.70 2615.20	
700ARXS2964A	774RXS2964	6 0.24	13x15° 0.51x15°	758.7 29.87	910.0 35.83	25.3 1.00	13.0 0.51	16 1690.00 3725.77	
705ARXS3131B	796RXS3131	6 0.24	6 0.24	784.5 30.89	986.0 38.82	34.0 1.34	19.0 0.75	16 2081.90 4580.10	
710ARXS3006	788RXS3006	4 0.16	17x20° 0.67x20°	773.5 30.45	931.5 36.67	25.3 1.00	13.0 0.51	16 1840.60 4049.40	
730ARXS2922	790RXS2922	3 0.12	20x20° 0.79x20°	776.3 30.56	908.0 35.75	22.0 0.87	12.0 0.47	16 1230.50 2707.20	
730ARXS3064	809RXS3064	6 0.24	21x20° 0.83x20°	793.9 31.26	959.0 37.76	25.3 1.00	13.0 0.51	16 2050.10 4510.20	
730ARXS3064	809RXS3064A	6 0.24	21x20° 0.83x20°	793.9 31.26	959.0 37.76	25.3 1.00	13.0 0.51	16 2043.70 4496.00	
750ARXS3005	813RXS3005	3 0.12	20x20° 0.79x20°	795.9 31.33	943.0 37.13	22.0 0.87	12.0 0.47	16 1508.70 3319.10	
760ARXS3166	846RXS3166B	8 0.31	19x20° 0.75x20°	830.5 32.70	1006.0 39.61	22.0 0.87	12.0 0.47	8 2423.00 5330.70	
761ARXS3166B	846RXS3166A	8 0.31	19x20° 0.75x20°	830.5 32.70	1006.0 39.61	22.0 0.87	12.0 0.47	8 2406.30 5293.90	
761ARXS3166	846RXS3166	8 0.31	19x20° 0.75x20°	830.5 32.70	1006.0 39.61	22.0 0.87	12.0 0.47	8 2402.60 5285.80	
770ARXS3151	847RXS3151	7.5 0.30	18x20° 0.71x20°	831.7 32.74	1003.0 39.49	25.3 1.00	13.0 0.51	16 1655.00 3648.61	
780ARXS3141	853RXS3141	6 0.24	25x20° 0.98x20°	835.9 32.91	1005.0 39.57	25.3 1.00	13.0 0.51	16 2142.00 4712.30	

Continued on next page.

FOUR-ROW CYLINDRICAL ROLLER BEARINGS – continued

Bearing Dimensions					Load Rating		Part Number	
Bore d	O.D. D	Width B	Width C	DUR/DOR F/E	Static C ₀	Dynamic C ₁ ⁽¹⁾	Bearing ⁽²⁾	Type
mm in.	mm in.	mm in.	mm in.	mm in.	kN lbf.	kN lbf.		
800.000 31.4961	1080.000 42.5197	700.000 27.5591	700.000 27.5591	878.000 34.5669	59200 13280000	22600 5100000	800RX3165	RX-1
800.000 31.4961	1080.000 42.5197	750.000 29.5276	750.000 29.5276	880.000 34.6457	58800 13240000	22600 5080000	800RX3164	RX-1
820.000 32.2835	1130.000 44.4882	650.000 25.5906	650.000 25.5906	891.000 35.0787	52400 11800000	23200 5220000	820RX3263	RX-1
820.000 32.2835	1100.000 43.3071	745.000 29.3307	720.000 28.3465	892.000 35.1181	57600 12960000	23000 5180000	820RX3201A	RX-10
820.000 32.2835	1130.000 44.4882	800.000 31.4961	800.000 31.4961	903.000 35.5512	68400 15360000	27400 6160000	820RX3264	RX-1
820.000 32.2835	1130.000 44.4882	800.000 31.4961	800.000 31.4961	903.000 35.5512	68400 15360000	27400 6160000	820RX3264A	RX-9
820.000 32.2835	1130.000 44.4882	825.000 32.4803	800.000 31.4961	903.000 35.5512	68400 15360000	27400 6160000	820RX3264C	RX-8
820.000 32.2835	1130.000 44.4882	825.000 32.4803	800.000 31.4961	903.000 35.5512	68400 15360000	27400 6160000	820RX3264D	RX-10
850.000 33.4646	1150.000 45.2756	840.000 33.0709	840.000 33.0709	928.000 36.5354	74800 16800000	28800 6480000	850RX3304	RX-1
850.000 33.4646	1180.000 46.4567	850.000 33.4646	850.000 33.4646	940.000 37.0079	72800 16400000	29600 6660000	850RX3365	RX-1
862.980 33.9756	1219.302 48.0040	876.300 34.5000	889.000 35.0000	956.000 37.6378	84000 18840000	34600 7780000	863RX3445A	RX-1
880.000 34.6457	1180.000 46.4567	750.000 29.5276	750.000 29.5276	945.000 37.2047	68000 15240000	27400 6140000	880RXK3364A	RXK-1
880.000 34.6457	1180.000 46.4567	750.000 29.5276	750.000 29.5276	945.300 37.2165	66400 14920000	26600 6000000	880RXK3366	RXK-2
900.000 35.4331	1220.000 48.0315	840.000 33.0709	840.000 33.0709	989.000 38.9370	78800 17680000	30200 6780000	900RX3444	RX-1
950.000 37.4016	1360.000 53.5433	1000.000 39.3701	1000.000 39.3701	1075.000 42.3228	108800 24480000	43200 9700000	950RX3723	RX-1
1040.000 40.9449	1439.890 56.6886	1000.000 39.3701	1000.000 39.3701	1133.000 44.6063	101200 22760000	42600 9580000	1040RX3882	RX-7

⁽¹⁾Based on 1×10^6 revolutions L_{10} life, for the ISO life calculation method.

⁽²⁾The radial internal clearance (RIC) for the bearing assembly must be included when ordering either a) the complete assembly or b) with the inner-ring set. It is advisable to order the inner-ring set independent of the outer ring set when the final grind of the inner-ring O.D. is accomplished after mounting on the roll neck.

Sub Assembly Part Numbers		Mounting Data				Lubrication Data			Weight
		Chamfer		Backing Diameter		Groove g	Hole Dia. h	Number of Holes z	
Inner-Ring Set ⁽²⁾	Outer-Ring Set	r _{smin}	r _{1smin}	Shaft d _s	Housing D _s				
		mm in.	mm in.	mm in.	mm in.	mm in.	mm in.	kg lbs.	
800ARXS3165	878RXS3165	3 0.12	20x20° 0.79x20°	864.3 34.03	1014.0 39.92	26.0 1.02	15.0 0.59	16 1915.60 4214.40	
800ARXS3164	880RXS3164	– –	18x20° 0.71x20°	863.7 34.00	1016.0 40.00	25.3 1.00	13.0 0.51	16 2050.00 4519.43	
820ARXS3263	891RXS3263	6 0.24	20x20° 0.79x20°	873.8 34.40	1061.0 41.77	25.3 1.00	13.0 0.51	16 2030.00 4475.34	
820ARXS3201A	892RXS3201A	3 0.12	22x20° 0.87x20°	872.2 34.34	1036.0 40.79	42.0 1.65	2x1.70 2x0.067	12 1969.80 4333.60	
820ARXS3264	903RXS3264	7.5 0.30	23x20° 0.91x20°	882.5 34.74	1059.0 41.69	36.0 1.42	20.0 0.79	16 2490.40 5478.80	
820ARXS3264	903RXS3264A	7.5 0.30	23x20° 0.91x20°	882.5 34.74	1059.0 41.69	46.0 1.81	2x1.70 2x0.067	12 2495.00 5497.50	
820ARXS3264C	903RXS3264	7.5 0.30	23x20° 0.91x20°	882.5 34.74	1059.0 41.69	36.0 1.42	20.0 0.79	16 2512.30 5527.10	
820ARXS3264C	903RXS3264A	7.5 0.30	23x20° 0.91x20°	882.5 34.74	1059.0 41.69	46.0 1.81	2x1.70 2x0.067	12 2495.00 5545.40	
850ARXS3304	928RXS3304	4 0.16	23x20° 0.91x20°	910.8 35.86	1080.0 42.52	22.0 0.87	12.0 0.47	16 2605.20 5731.50	
850ARXS3365	940RXS3365	7.5 0.30	25x11°20' 0.98x11°20'	911.7 35.89	1106.0 43.54	36.0 1.42	20.0 0.79	16 2870.00 6408.00	
863ARXS3445A	956RXS3445A	5 0.20	12x20° 0.47x20°	938.2 36.94	1140.0 44.88	25.3 1.00	13.0 0.51	16 3431.30 7548.90	
880ARVKS3364	945RXS3364A	7.5 0.30	8 0.31	930 36.61	1105.0 43.50	46.0 1.81	2x1.70 2x0.067	8 2510.70 5523.60	
880ARVKS3366	945RXS3366	7.5 0.30	8 0.31	930 36.61	1105.0 43.50	27.0 1.06	15.0 0.59	20 2497.40 5494.20	
900ARXS3444	989RXS3444	4 0.16	24x24° 0.95x20°	971.8 38.26	1149.0 45.24	22.0 0.87	12.0 0.47	16 2959.20 6510.30	
950ARXS3723	1075RXS3723	5 0.20	22x24° 0.87x20°	1057.1 41.62	1275.0 50.20	34.0 1.34	19.0 0.75	16 4987.00 10971.50	
1040ARXS3882	1133RXS3882	7.5 0.30	27x20° 1.06x20°	1110.2 43.71	1353.0 53.27	22.0 0.87	12.0 0.47	16 4975.50 10969.80	

HJ SERIES

- Clearance fit suggested for outer ring when housing is stationary relative to load.
- Tight transition fit suggested if housing rotates relative to load.
- Consult your Timken representative for oscillating applications (e.g., low radial-clearance concerns).
- Unmarked end of outer ring should be assembled against housing shoulder to clear maximum allowed housing fillet $r_{a\max}$ (equal to $r_{s\min}$).
- Meets Military Standard MS 51961.

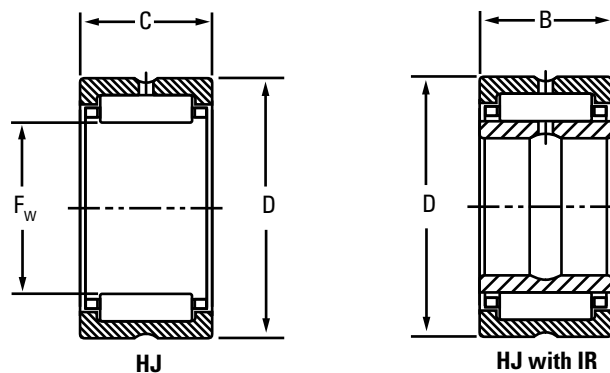

Shaft Diameter	Dimensions				Bearing Designation	Used With Inner Ring Designation	Load Rating		Speed Ratings	
	F_w	D	C/B	$r_{s\min}$			Static C_0	Basic Dynamic $C^{(1)}$	Oil	Grease
in.	mm in.	mm in.	mm in.	mm in.			kN lbf.	kN lbf.	RPM	
3.75	95.25 3.75	120.65 4.75	50.8 2	2.54 0.1	HJ-607632	IR-506032 IR-526032	398 89400	193 43300	3700	3300
4	101.6 4	127 5	50.8 2	2.54 0.1	HJ-648032	IR-526432 IR-546432 IR-566432 IR-566432	428 96200	201 45100	3500	3100
4.25	107.95 4.25	133.35 5.25	50.8 2	2.54 0.1	HJ-688432	IR-566832 IR-606832	444 99900	203 45700	3300	2900
4.5	114.3 4.5	152.4 6	57.15 2.25	2.54 0.1	HJ-729636	IR-607236	517 116000	285 64000	3200	2800
	114.3 4.5	152.4 6	63.5 2.5	2.54 0.1	HJ-729640	IR-607240	599 135000	320 71900	3200	2800
5	127 5	165.1 6.5	50.8 2	2.54 0.1	HJ-8010432	—	517 116000	278 62400	2800	2400
	127 5	165.1 6.5	57.15 2.25	2.54 0.1	HJ-8010436	IR-648036 IR-688036	590 133000	308 69200	2800	2500
	127 5	165.1 6.5	63.5 2.5	2.54 0.1	HJ-8010440	IR-648040	684 154000	345 77600	2800	2500
5.5	139.7 5.5	177.8 7	63.5 2.5	2.54 0.1	HJ-8811240	IR-728840	697 157000	342 76900	2600	2300
	139.7 5.5	177.8 7	76.2 3	2.54 0.1	HJ-8811248	IR-728848	883 198000	411 92400	2500	2200
5.75	146.05 5.75	184.15 7.25	76.2 3	3.05 0.12	HJ-9211648	IR-769248	918 206000	419 94200	2400	2100
6	152.4 6	190.5 7.5	63.5 2.5	3.05 0.12	HJ-9612040	IR-809640	777 175000	364 81800	2300	2000
	152.4 6	190.5 7.5	76.2 3	3.05 0.12	HJ-9612048	IR-809648	984 221000	438 98400	2200	2000

⁽¹⁾ C_g factor for bearing without inner ring.

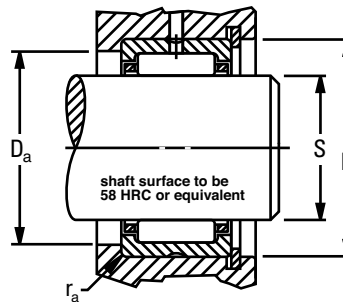

Weight	Geometry Factor $C_g^{(1)}$	Mounting Dimensions Clearance Fit				Bearing Designation	Mounting Dimensions Tight Transition Fit				Shoulder Diameter $\pm 0.38 \pm 0.015$ D_a
		Max.	Min.	Max.	Min.		S		H		
kg lbs.	mm in.	mm in.	mm in.	mm in.	mm in.	mm in.	mm in.	mm in.	mm in.	mm in.	
1.455 3.208	0.1011	95.25 3.75	95.227 3.7491	120.691 4.7516	120.65 4.75	HJ-607632	95.217 3.7487	95.192 3.7477	120.594 4.7478	120.635 4.7494	111.13 4.375
1.541 3.397	0.106	101.6 4	101.577 3.9991	127.041 5.0016	127 5	HJ-648032	101.564 3.9986	101.542 3.9977	126.944 4.9978	126.985 4.9994	117.48 4.625
1.626 3.586	0.1099	107.95 4.25	107.927 4.2491	133.391 5.2516	133.35 5.25	HJ-688432	107.914 4.2486	107.892 4.2477	133.294 5.2478	133.335 5.2494	123.83 4.875
3.035 6.691	0.1100	114.3 4.5	114.277 4.4991	152.441 6.0016	152.4 6	HJ-729636	114.264 4.4986	114.242 4.4977	152.344 5.9978	152.385 5.9994	138.11 5.438
3.372 7.434	0.1137	114.3 4.5	114.277 4.4991	152.441 6.0016	152.4 6	HJ-729640	114.264 4.4986	114.242 4.4977	152.344 5.9978	152.385 5.9994	138.11 5.438
2.66 5.86	0.1162	127 5	126.975 4.999	165.141 6.5016	165.1 6.5	HJ-8010432	126.959 4.9984	126.934 4.9974	165.044 6.4978	165.085 6.4994	150.81 5.938
3.324 7.327	0.1188	127 5	126.975 4.999	165.141 6.5016	165.1 6.5	HJ-8010436	126.959 4.9984	126.934 4.9974	165.044 6.4978	165.085 6.4994	150.81 5.938
3.693 8.141	0.1213	127 5	126.975 4.999	165.141 6.5016	165.1 6.5	HJ-8010440	126.959 4.9984	126.934 4.9974	165.044 6.4978	165.085 6.4994	150.81 5.938
4.014 8.849	0.1297	139.7 5.5	139.675 5.499	177.841 7.0016	177.8 7	HJ-8811240	139.659 5.4984	139.634 5.4974	177.744 6.9978	177.785 6.9994	163.51 6.438
4.817 10.62	0.1369	139.7 5.5	139.675 5.499	177.841 7.0016	177.8 7	HJ-8811248	139.659 5.4984	139.634 5.4974	177.744 6.9978	177.785 6.9994	163.51 6.438
5.009 11.04	0.1409	146.05 5.75	146.025 5.749	184.196 7.2518	184.15 7.25	HJ-9211648	146.009 5.7484	145.984 5.7474	184.089 7.2476	184.135 7.2494	169.86 6.688
4.335 9.557	0.1384	152.4 6	152.375 5.999	190.546 7.5018	190.5 7.5	HJ-9612040	152.359 5.9984	152.334 5.9974	190.439 7.4976	190.485 7.4994	176.21 6.938
5.202 11.47	0.1461	152.4 6	152.375 5.999	190.546 7.5018	190.5 7.5	HJ-9612048	152.359 5.9984	152.334 5.9974	190.439 7.4976	190.485 7.4994	176.21 6.938

Continued on next page.

HJ SERIES – continued

Shaft Diameter	Dimensions				Bearing Designation	Used With Inner Ring Designation	Load Rating		Speed Ratings	
	F _w	D	C/B	r _{s min}			Static C ₀	Basic Dynamic C ⁽¹⁾	Oil	Grease
in.	mm in.	mm in.	mm in.	mm in.			kN lbf.	kN lbf.	RPM	
6.5	165.1 6.5	203.2 8	63.5 2.5	3.05 0.12	HJ-10412840	IR-8810440	832 187000	376 84600	2100	1800
	165.1 6.5	203.2 8	76.2 3	3.05 0.12	HJ-10412848	IR-8810448	1050 237000	452 102000	2000	1800
7.25	184.15 7.25	231.775 9.125	76.2 3	3.05 0.12	HJ-11614648	IR-9611648	1130 253000	524 118000	1800	1600
7.75	196.85 7.75	244.475 9.625	76.2 3	3.05 0.12	HJ-12415448	IR-10412448	1210 271000	543 122000	1600	1400
8.25	209.55 8.25	257.175 10.125	76.2 3	3.05 0.12	HJ-13216248	IR-11213248	1290 290000	563 126000	1500	1300
8.75	222.25 8.75	269.875 10.625	76.2 3	4.06 0.16	HJ-14017048	IR-12014048	1370 308000	581 131000	1400	1200
9.25	234.95 9.25	282.575 11.125	76.2 3	4.06 0.16	HJ-14817848	IR-12814848	1350 326000	599 145000	1300	1200

⁽¹⁾C_g factor for bearing without inner ring.

Weight	Geometry Factor $C_g^{(1)}$	Mounting Dimensions Clearance Fit				Bearing Designation	Mounting Dimensions Tight Transition Fit				Shoulder Diameter $\pm 0.38 \pm 0.015 D_a$
		Max.	Min.	Max.	Min.		S		H		
							Max.	Min.	Max.	Min.	
kg lbs.	mm in.	mm in.	mm in.	mm in.	mm in.	mm in.	mm in.	mm in.	mm in.	mm in.	
4.656 10.26	0.1459	165.1 6.5	165.075 6.499	203.246 8.0018	203.2 8	HJ-10412840	165.059 6.4984	165.034 6.4974	203.139 7.9976	203.185 7.9994	188.91 7.438
5.582 12.31	0.1539	165.1 6.5	165.075 6.499	203.246 8.0018	203.2 8	HJ-10412848	165.059 6.4984	165.034 6.4974	203.139 7.9976	203.185 7.9994	188.91 7.438
7.888 17.39	0.1586	184.15 7.25	184.12 7.2488	231.821 9.1268	231.775 9.125	HJ-11614648	184.099 7.248	184.069 7.2468	231.714 9.1226	231.76 9.1244	216.0 8.5
8.37 18.45	0.1662	196.85 7.75	196.82 7.7488	244.521 9.6268	244.475 9.625	HJ-12415448	196.799 7.748	196.769 7.7468	244.414 9.6226	244.46 9.6244	228.6 9
8.852 19.51	0.1736	209.55 8.25	209.52 8.2488	257.226 10.127	257.175 10.125	HJ-13216248	209.499 8.248	209.469 8.2468	257.109 10.122	257.16 10.124	241.3 9.5
9.333 20.58	0.181	222.25 8.75	222.22 8.7488	269.926 10.627	269.875 10.625	HJ-14017048	222.199 8.748	222.169 8.7468	269.809 10.622	269.86 10.624	254 10
9.815 21.64	0.1885	234.95 9.25	234.92 9.2488	282.626 11.127	282.575 11.125	HJ-14817848	234.899 9.248	234.869 9.2468	282.509 11.122	282.56 11.124	266.7 10.5

INNER RINGS (IR)

- Ideal choice where the shaft is not practical to use as inner raceway.
- Designed to meet established inch tolerances.
- Maximum shaft fillet radius cannot exceed inner-ring bore chamfer as shown.
- Optional centralized lubrication groove (bore) or through-hole available – specify when ordering.
- Designed to be axially clamped against shoulder for loose transition fit on shaft.
- After mounting, for tight transition fit (keeping inner ring from rotating relative to shaft), inner-ring O.D. must not exceed raceway diameter on matching bearing.
- After mounting, if O.D. of inner ring exceeds the required raceway diameter for matching bearing, ring should be ground to proper diameter while mounted on shaft.
- Unmarked end of inner ring to be assembled against the shaft shoulder to ensure clearing the maximum allowable shaft fillet as indicated in tables shown.

Shaft Diameter	Dimensions				Inner-Ring Designation	Weight	Loose Transition Fit S		Interference Fit		Used with Bearing Designation
	d	F	B	r _{s min}			Max.	Min.	Max.	Min.	
in.	mm in.	mm in.	mm in.	mm in.	kg lbs.	mm in.	mm in.	mm in.	mm in.		
3.125	79.375 3.125	95.25 3.75	50.8 2	2.54 0.1	IR-506032	0.88 1.94	79.365 3.1246	79.347 3.1239	79.398 3.1259	79.385 3.1254	HJ-607632
3.25	82.55 3.25	95.25 3.75	50.8 2	2.54 0.1	IR-526032	0.708 1.56	82.537 3.2495	82.517 3.2487	82.578 3.2511	82.563 3.2505	HJ-607632
	82.55 3.25	101.6 4	50.8 2	2.54 0.1	IR-526432	1.089 2.4	82.537 3.2495	82.517 3.2487	82.578 3.2511	82.563 3.2505	HJ-648032
3.375	85.725 3.375	101.6 4	50.8 2	2.54 0.1	IR-546432	0.93 2.05	85.712 3.3745	85.692 3.3737	85.753 3.3761	85.738 3.3755	HJ-648032
3.5	88.9 3.5	101.6 4	50.8 2	2.54 0.1	IR-566432	0.757 1.67	88.887 3.4995	88.867 3.4987	88.928 3.5011	88.913 3.5005	HJ-648032
	88.9 3.5	107.95 4.25	50.8 2	2.54 0.1	IR-566832	1.179 2.6	88.887 3.4995	88.867 3.4987	88.928 3.5011	88.913 3.5005	HJ-688432
3.75	95.25 3.75	107.95 4.25	50.8 2	2.54 0.1	IR-606832	1.012 2.23	95.237 3.7495	95.217 3.7487	95.278 3.7511	95.263 3.7505	HJ-688432
	95.25 3.75	114.3 4.5	57.15 2.25	2.54 0.1	IR-607236	1.406 3.1	95.237 3.7495	95.217 3.7487	95.278 3.7511	95.263 3.7505	HJ-729636
	95.25 3.75	114.3 4.5	63.5 2.5	2.54 0.1	IR-607240	1.565 3.45	95.237 3.7495	95.217 3.7487	95.278 3.7511	95.263 3.7505	HJ-729640
4	101.6 4	127 5	57.15 2.25	2.54 0.1	IR-648036	2.046 4.51	101.587 3.9995	101.567 3.9987	101.628 4.0011	101.613 4.0005	HJ-8010436
	101.6 4	127 5	63.5 2.5	2.54 0.1	IR-648040	2.272 5.01	101.587 3.9995	101.567 3.9987	101.628 4.0011	101.613 4.0005	HJ-8010440
4.25	107.95 4.25	127 5	57.15 2.25	2.54 0.1	IR-688036	1.565 3.45	107.937 4.2495	107.917 4.2487	107.978 4.2511	107.963 4.2505	HJ-8010436
4.5	114.3 4.5	139.7 5.5	63.5 2.5	2.54 0.1	IR-728840	2.495 5.5	114.287 4.4995	114.267 4.4987	114.328 4.5011	114.313 4.5005	HJ-8811240
	114.3 4.5	139.7 5.5	76.2 3	2.54 0.1	IR-728848	2.989 6.59	114.287 4.4995	114.267 4.4987	114.328 4.5011	114.313 4.5005	HJ-8811248
4.75	120.65 4.75	146.05 5.75	76.2 3	3.05 0.12	IR-769248	3.18 7.01	120.635 4.7494	120.612 4.7485	120.683 4.7513	120.665 4.7506	HJ-9211648

Continued on next page.

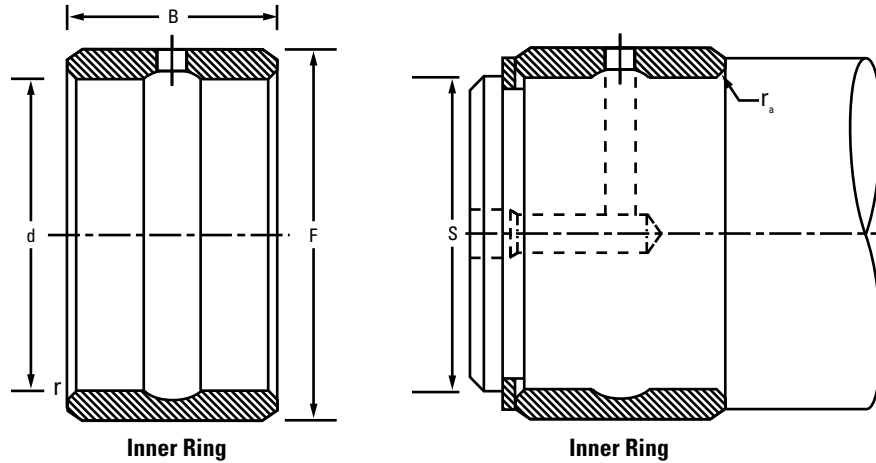

Shaft Diameter	Dimensions				Inner-Ring Designation	Weight	Loose Transition Fit S		Interference Fit		Used with Bearing Designation
	d	F	B	r _{s min}			Max.	Min.	Max.	Min.	
in.	mm in.	mm in.	mm in.	mm in.		kg lbs.	mm in.	mm in.	mm in.	mm in.	
5	127 5	152.4 6	63.5 2.5	3.05 0.12	IR-809640	2.781 6.13	126.985 4.9994	126.962 4.9985	127.033 5.0013	127.015 5.0006	HJ-9612040
	127 5	152.4 6	76.2 3	3.05 0.12	IR-809648	3.325 7.33	126.985 4.9994	126.962 4.9985	127.033 5.0013	127.015 5.0006	HJ-9612048
5.5	139.7 5.5	165.1 6.5	63.5 2.5	3.05 0.12	IR-8810440	3.035 6.69	139.685 5.4994	139.662 5.4985	139.733 5.5013	139.715 5.5006	HJ-10412840
	139.7 5.5	165.1 6.5	76.2 3	3.05 0.12	IR-8810448	3.629 8	139.685 5.4994	139.662 5.4985	139.733 5.5013	139.715 5.5006	HJ-10412848
6	152.4 6	184.15 7.25	76.2 3	3.05 0.12	IR-9611648	4.935 10.88	152.385 5.9994	152.362 5.9985	152.433 6.0013	152.415 6.0006	HJ-11614648
6.5	165.1 6.5	196.85 7.75	76.2 3	3.05 0.12	IR-10412448	5.343 11.78	165.085 6.4994	165.062 6.4985	165.133 6.5013	165.115 6.5006	HJ-12415448
7	177.8 7	209.55 8.25	76.2 3	3.05 0.12	IR-11213248	5.389 11.88	177.785 6.9994	177.762 6.9985	177.833 7.0013	177.815 7.0006	HJ-13216248
7.5	190.5 7.5	222.25 8.75	76.2 3	4.06 0.16	IR-12014048	6.11 13.47	190.485 7.4994	190.454 7.4982	190.536 7.5014	190.515 7.5006	HJ-14017048
8	203.2 8	234.95 9.25	76.2 3	4.06 0.16	IR-12814848	6.518 14.37	203.185 7.9994	203.154 7.9982	203.236 8.0014	203.215 8.0006	HJ-14817848

5200, A5200 METRIC SERIES

- Ring tolerances are found on page 39.
- Life and load calculations are found in the engineering section of this catalog.
- Shaft and housing fits, tolerances and shaft diameters are found on page 38.

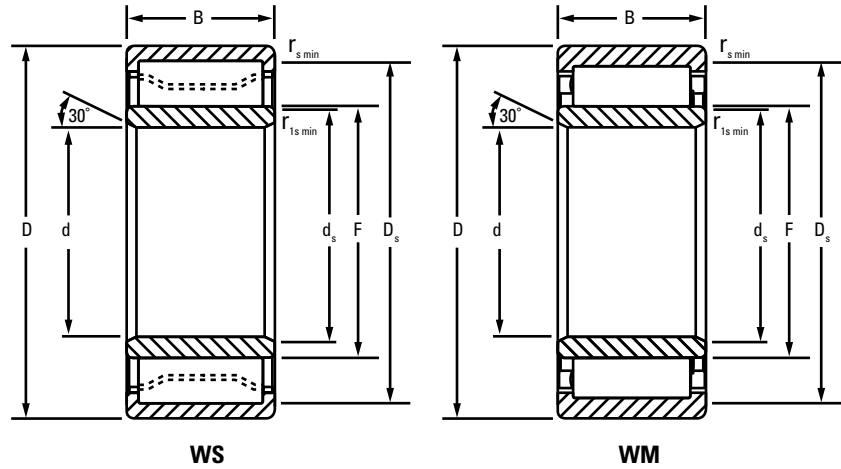

Outer ring and roller assembly + **Inner rings⁽¹⁾** = **Complete bearing**

IN THE BEARING NUMBER

W = double-ribbed outer ring.

S = stamped-steel, land-riding cage.

M = machined-brass, land-riding cage.

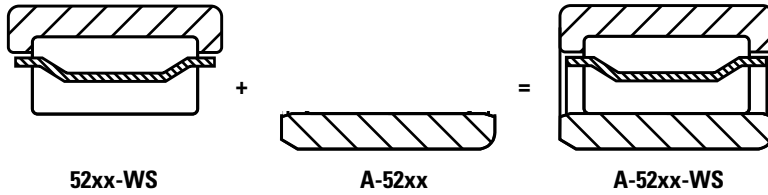

⁽¹⁾Inner ring can be ordered separately.

Bearing Dimensions				Load Rating		Part Number		Mounting Data				s ⁽³⁾	Geo- metry Factor C _g	Thermal Speed Ratings		Weight
								Chamfer		Backing Diameter				Oil	Grease	
Bore d	O.D. D	Width B	DUR/DOR F/E	Static C ₀	Dynamic C ₁ ⁽¹⁾	Bearing ⁽²⁾	Type	r _{smin}	r _{1smin}	Shaft d _s	Housing D _s					RPM
mm in.	mm in.	mm in.	mm in.	kN lbf.	kN lbf.			mm in.	mm in.	mm in.	mm in.	mm in.		RPM	RPM	kg lbs.
100.000 3.9370	180.000 7.0866	60.325 2.3750	121.133 4.7690	594 134000	474 107000	A-5220-WS	WS	4.4 0.16	2.1 0.08	117.1 4.61	165.6 6.52	4.26 0.168	0.131	2800	2500	6.30 14.00
110.000 4.3307	200.000 7.8740	69.850 2.7500	133.078 5.2393	790 178000	612 138000	A-5222-WS	WS	4.4 0.16	2.1 0.08	128.8 5.07	182.3 7.18	4.29 0.169	0.144	2400	2100	9.20 20.30
120.000 4.7244	215.000 8.4646	76.200 3.0000	145.265 5.7191	952 214000	707 159000	A-5224-WS	WS	5.5 0.22	2.1 0.08	140.1 5.52	196.1 7.72	4.29 0.169	0.155	2200	1900	11.60 25.60
130.000 5.1181	230.000 9.0551	79.375 3.1250	155.115 6.1069	1070 240000	795 179000	A-5226-WS	WS	5.5 0.22	3.0 0.12	149.7 5.89	210.7 8.30	4.90 0.193	0.162	2000	1700	13.50 29.80
140.000 5.5118	250.000 9.8425	82.550 3.2500	168.603 6.6379	1210 272000	899 202000	A-5228-WS	WS	5.5 0.22	3.0 0.12	163.2 6.43	229.1 9.02	5.13 0.202	0.172	1700	1600	16.80 37.10
150.000 5.9055	270.000 10.6299	88.900 3.5000	181.696 7.1534	1470 330000	1080 243000	A-5230-WS	WS	7.5 0.30	3.0 0.12	176.3 6.94	248.4 9.78	5.13 0.202	0.154	1500	1400	21.30 46.90
160.000 6.2992	290.000 11.4173	98.425 3.8750	193.787 7.6294	1750 394000	1270 285000	A-5232-WS	WS	7.5 0.30	3.0 0.12	187.8 7.39	265.3 10.44	5.46 0.215	0.164	1400	1200	27.50 60.50
170.000 6.6929	310.000 12.2047	104.775 4.1250	205.636 8.0959	2040 459000	1450 326000	A-5234-WS	WS	7.5 0.30	4.0 0.16	201.6 7.94	285.8 11.25	3.40 0.13	0.172	1200	1100	37.60 82.90
180.000 7.0866	320.000 12.5984	107.950 4.2500	216.441 8.5213	2130 479000	1510 341000	A-5236-WS	WS	7.5 0.30	4.0 0.16	209.0 8.23	294.3 11.59	4.60 0.181	0.178	1200	1100	35.70 78.60
190.000 7.4803	340.000 13.3858	114.300 4.5000	229.105 9.0199	2340 526000	1670 376000	A-5238-WS	WS	9.5 0.37	4.0 0.16	223.8 8.81	312.7 12.31	5.70 0.22	0.186	1100	1010	48.50 107.00
200.000 7.8740	360.000 14.1732	120.650 4.7500	242.369 9.5421	2370 534000	1600 360000	A-5240-WM	WM	9.5 0.37	4.0 0.16	233.0 9.17	318.6 12.54	6.00 0.24	0.189	1100	990	57.60 127.00
220.000 8.6614	400.000 15.7480	133.350 5.2500	266.078 10.4755	3340 750000	2300 517000	A-5244-WM	WM	11.0 0.43	4.0 0.16	260.4 10.25	366.7 14.44	4.60 0.18	0.211	860	790	76.40 175.00
240.000 9.4488	440.000 17.3228	146.050 5.7500	291.368 11.4712	4010 902000	2750 619000	A-5248-WM	WM	11.0 0.43	4.0 0.16	285.0 11.22	402.4 15.84	4.75 0.19	0.228	750	690	106.10 234.00

⁽¹⁾Based on 1 x 10⁶ revolutions L₁₀ life, for the ISO life calculation method.

⁽²⁾The radial internal clearance (RIC) for the bearing assembly must be included when ordering either a) the complete assembly or b) with the inner-ring set.

⁽³⁾Permissible axial displacement from normal position of one bearing ring in relation to the other.

TIMKEN

The Timken team applies their know-how to improve the reliability and performance of machinery in diverse markets worldwide. The company designs, makes and markets bearings, gear drives, automated lubrication systems, belts, brakes, clutches, chain, couplings, linear motion products and related power transmission rebuild and repair services.

Price: USD \$75

Stronger. By Design.

www.timken.com